

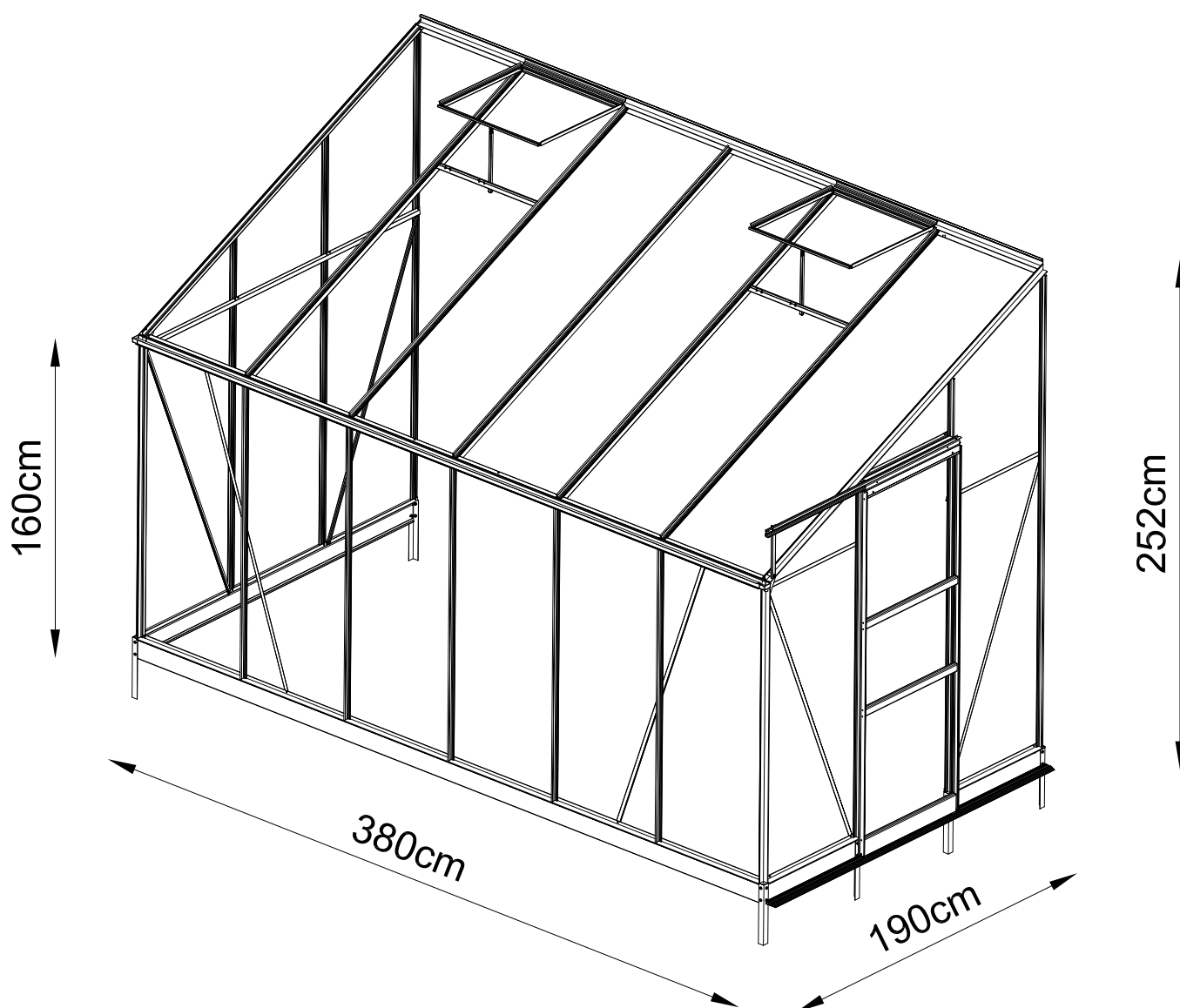

FR	<b>Notice de montage de la serre</b>	2
EN	<b>Greenhouse assembly instructions</b>	28
DE	<b>Montageanleitung für das Gewächshaus</b>	54
ES	<b>Instrucciones de montaje del invernadero</b>	80
IT	<b>Istruzioni per il montaggio della serra</b>	106
PL	<b>Instrukcja montażu szklarni</b>	132



Dimensions (LxIxH) : 380x190x224 cm | Dimensions: 380x190x224 cm  
Abmessungen (LxBxH): 380x190x224 cm | Dimensiones: (LxAnxAl): 380x190x224 cm  
Dimensioni: ( LxPxH): 380x190x224 cm | Wymiary: 380x190x224 cm

Cher client

Félicitations pour l'achat de votre nouvelle serre de jardin. Merci de lire attentivement les instructions suivantes avant de procéder au montage.

**Attention : avant d'attaquer la construction de votre serre, prenez le temps nécessaire pour identifier tous les dangers possibles tels que des câbles enterrés ou aériens ou des canalisations, etc...**



### Lieu d'installation

- ☑ Un endroit ensoleillé, dégagé, orienté nord, protégé des vents violents, est le lieu le plus adapté pour tirer le meilleur de votre serre.
- ☑ Votre serre doit être positionnée sur un sol plat et plan. De nombreuses options de fondations peuvent convenir à vos besoins. Les serres sont livrées avec une embase pour répondre à la plupart des besoins de montage.
- ☑ L'accès à l'eau et à l'électricité doit être envisagé à un stade précoce et avant que des fondations solides ne soient posées.
- ☑ Il est conseillé d'avoir suffisamment d'accès autour de votre nouvelle serre pendant son installation et ensuite pour son entretien.

### Implantation



- ☑ Assemblez le cadre en aluminium (sans le vitrage) et positionnez-le en l'endroit de pose, pour pouvoir creuser vos trous pour les fondations. Cela vous permettra de localiser et de marquer la position exacte des trous de poteaux pour l'ancrage.
- ☑ Une fois que vous avez marqué vos positions d'ancrage, déplacez le cadre de la serre afin de permettre de creuser les trous.
- ☑ Une profondeur minimale de 60cm et un diamètre de 20cm sont recommandés. Une fois les piquets d'ancrage fixés à la base et aux équerres, vous pouvez lever la serre au-dessus des trous et l'abaisser au niveau du sol.
- ☑ Une fois que vous êtes satisfait de la position finale et que vous vous êtes assurés que le cadre est d'équerre, de niveau et plan, le béton peut être coulé dans les trous d'ancrage.







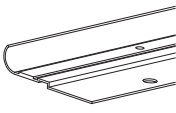
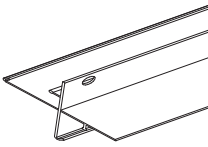
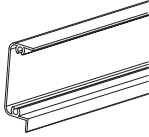
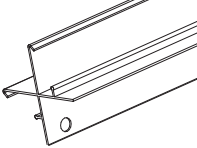
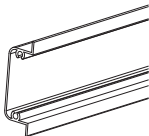
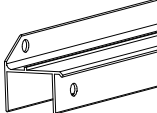
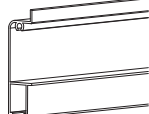
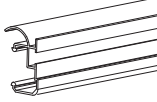
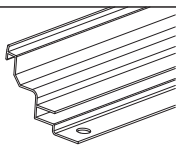
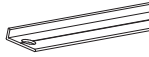
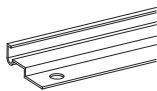
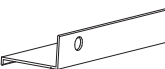
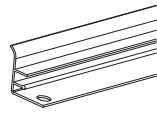
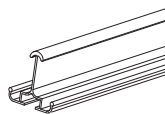
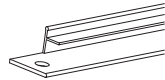
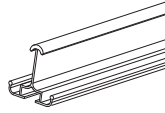
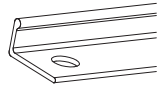
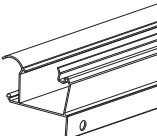
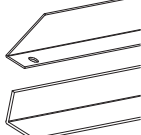
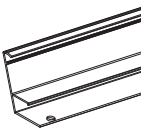

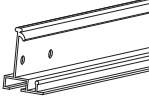

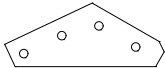

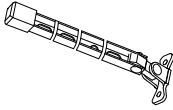

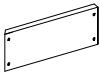





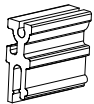

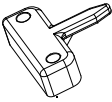

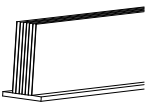

### Fixation sur une base solide

- ☑ Utilisez le plan de base fourni avec le manuel d'instructions comme guide pour construire votre base solide, qu'elle soit en bois, en brique, en béton, ...
- ☑ Les fixations sont situées à l'intérieur et à environ 55mm de la base en aluminium de 43mm.

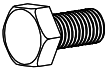
### Vitrage

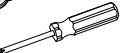
- ☑ Une fois la pose du cadre en aluminium terminée, celle du vitrage peut commencer.
- ☑ Bien que tous les verres soient en verre de sécurité trempé, ils doivent toujours être considérés comme dangereux et manipulés avec prudence.
- ☑ Assurez-vous que le cadre est exempt de débris avant de commencer. Méfiez-vous du vent en permanence.
- ☑ Si vous posez des panneaux à côté de la serre pendant la construction, une position inclinée est recommandée.
- ☑ Commencez par les panneaux de toit et travaillez d'un bout à l'autre.
- ☑ Pour insérer les panneaux de toit, appuyez-vous contre les gouttières et faites-les glisser entre les barres d'armature jusqu'à ce qu'ils atteignent le faîte et trouvent leur place.
- ☑ Glissez les panneaux muraux en les inclinant entre les barres d'aluminium verticales, poussez les vers le haut et jusque dans la feuillure située sous la gouttière.
- ☑ Assurez-vous que le bas du panneau de verre repose correctement sur le dessus de la base.
- ☑ Le panneau aura une apparence carrée et d'aplomb et sera sécurisé par la rainure en bas et par la feuillure en haut.
- ☑ Insérez les joints caoutchoucs en appuyant avec votre pouce et votre index pour vous guider.
- ☑ Tous les caoutchoucs sont fabriqués plus longs que nécessaire et doivent être coupés une fois ajustés.
- ☑ Si l'extrusion de caoutchouc semble sèche, utilisez de l'eau savonneuse pour faciliter l'installation dans la barre de vitrage.
- ☑ Les joints doivent avoir l'air plats et droits une fois l'opération terminée.
- ☑ Laissez les caoutchoucs pendant une heure ou deux avant de les couper à la longueur requise, car ils peuvent s'étirer puis se rétracter lors de l'insertion.
- ☑ Ne coupez pas les caoutchoucs avant de les avoir tous insérés.

Pièce	#	mm	Qté	Pièce	#	mm	Qté
	L12	640	1		L01A L01B	2073 2073	1 1
	L13A	640	1		L01C L01D	1474 1474	1 1
	L13B	640	2		L04	592	1
	L38	640	1		L05	1300	1
	L15	602	2		L06A L06B L06C L06D	1547 620 640 1558	4 1 1 2
	L16	602	2		L07A L07B L07C L07D	1869 3706 626 646	1 1 1 1
	L17	700	4		L08A L08B L08C L08D	2358 2358 1780 1780	1 1 1 1
	L18	638	2		L08E L08F L08G L08H	1474 2046 2069 2069	5 5 1 1
	L21	259	1		L09	3708	1
	L22 L23	1865 2042	1 5		L10	3708	1
	L37	1842	1		L11A L11B	1816 1816	1 1

Pièce	#	mm	Qté	Pièce	#	mm	Qté
	M01	M6	113		W2		2
	M02	M5	2				
	Z01	Ø4*16	24		W5		2
	Z02	Ø4*6	4				
	H3		2		W07A	655	1
					W07B	645	1
					W07C	3758	1
					W07D	1900	1
	J04		1		W08	350	6
					W09		13
	J04L		1		W11		20
	J04R		1		W13	Ø12*28	3
	J11		2		W14		210
	J13		4		W15		6
	J15	Ø6.5*20	4		W21	Ø12*Ø6*1.5	2
					W16		1
					W17		1
	J18	1.82M	2		W46		2
	J19	78M	1		S01	M6*10	90
					S02	M6*16	24
					S03	M6*40	3
	T01		1		S04	M6*14	5
	T02		1		S05	M5*25	2
	S04				S07	M6*60	12

**Conseil important :** Vous n'aurez pas besoin de tout démonter si vous avez oublié de mettre les vis S01, vous pouvez les remplacer par les vis S04 !

## Assemblage de la base

Il est essentiel que la base de la serre soit parfaitement carrée afin que les mesures diagonales soient identiques. La serre doit également être uniformément à niveau de la façade avant et de la façade arrière, l'aplomb doit être parfait.

L'ancrage de la serre dans le sol est essentiel. Nous vous recommandons d'utiliser des ancrs de maçonnerie si vous avez une dalle, auquel cas vous couperiez les pattes d'ancrage. Alternativement, les pattes d'ancrage peuvent être bétonnées dans le sol (semelle min 300 mm de diamètre et 400 mm de profondeur). Il est souvent préférable de le faire à la fin, si le temps le permet. Fixez toujours la structure temporairement pendant la construction.

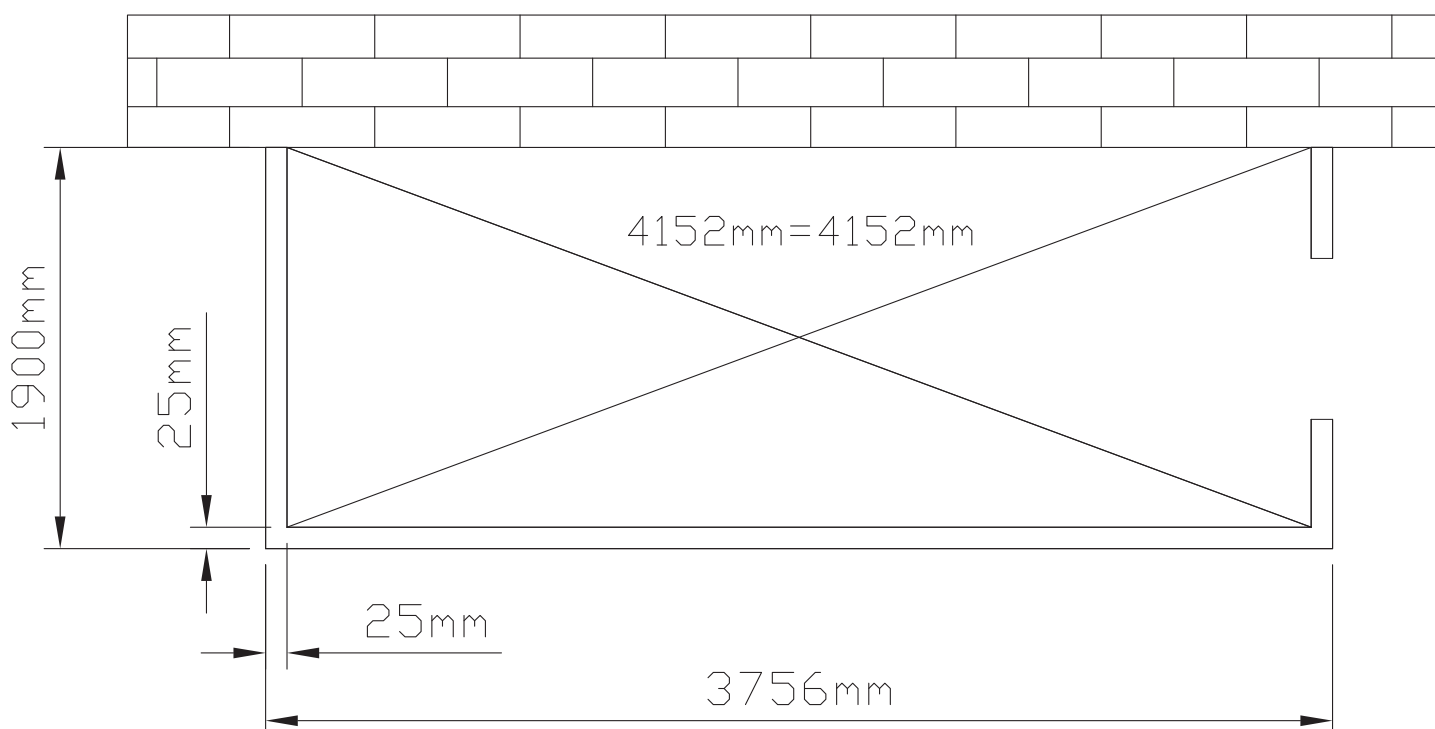
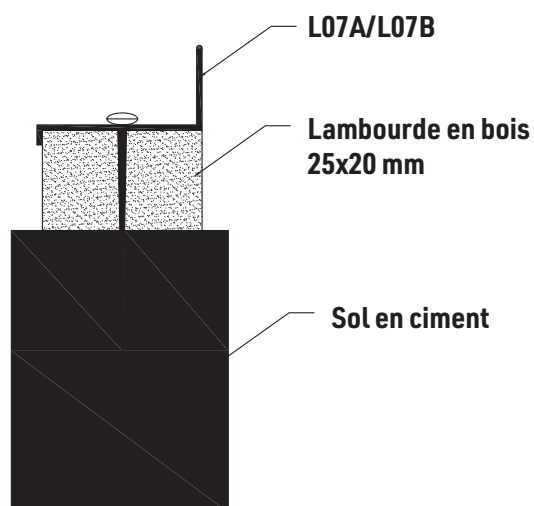

# Assemblage de la base

**Note :** Veuillez retirer le film de protection sur la surface des pièces W08 et W07 A (B/C/D) avant d'assembler la base

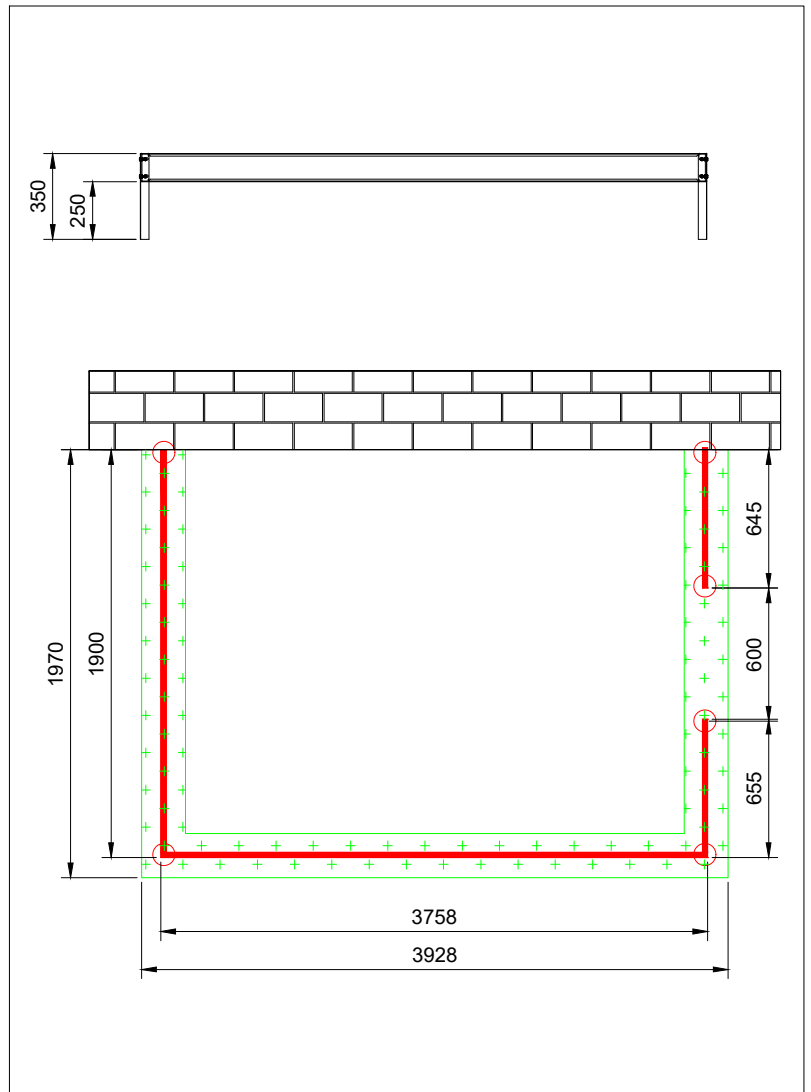
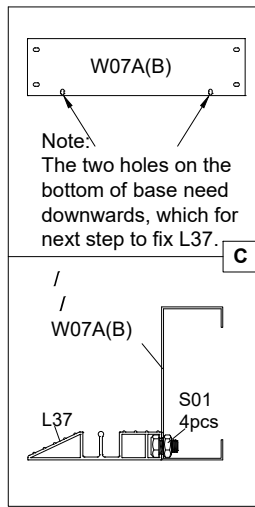
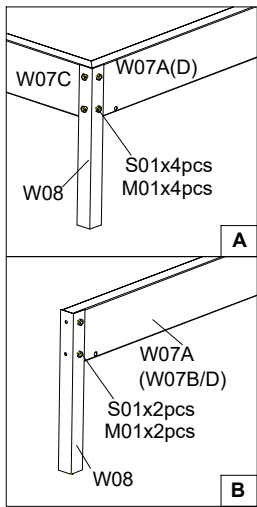
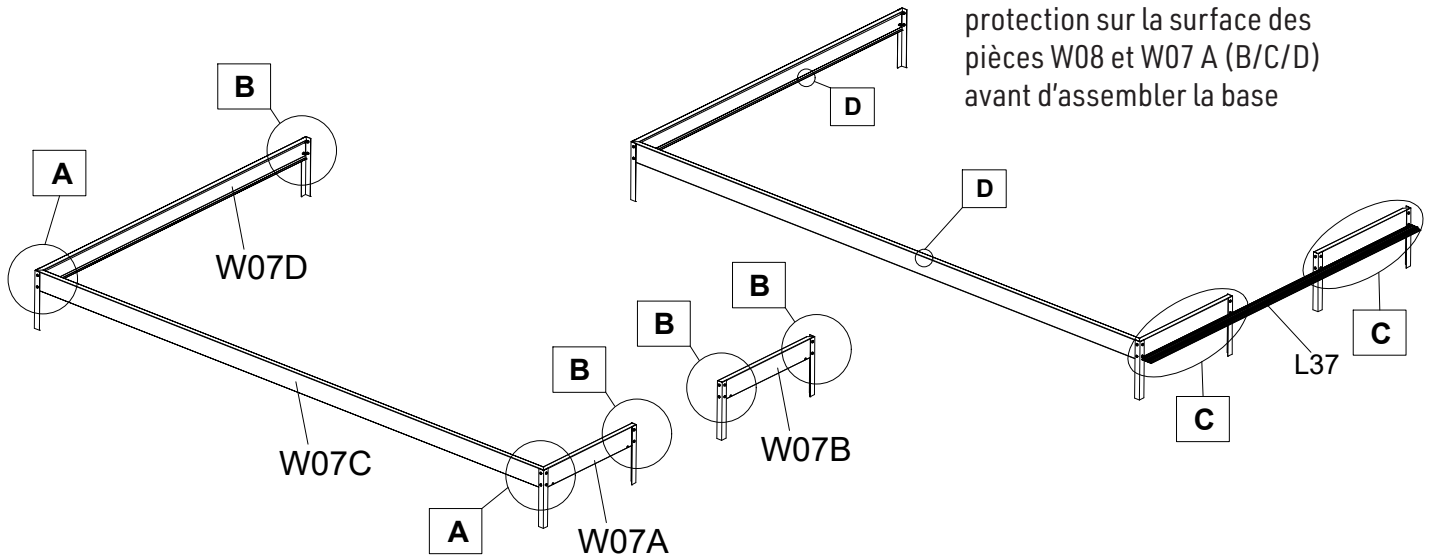

# Assemblage de la porte

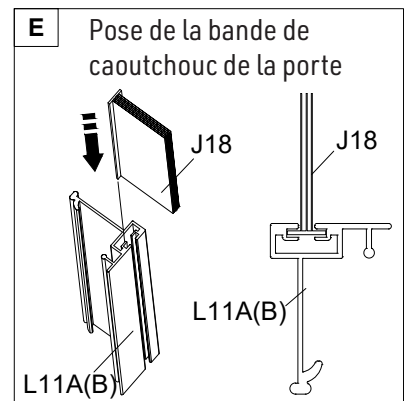
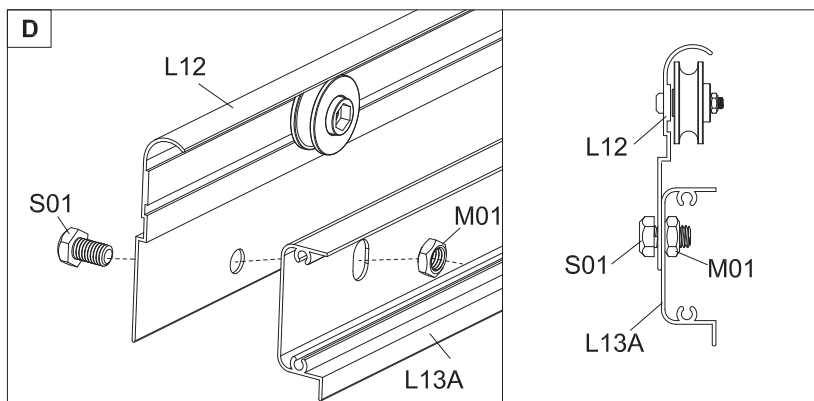
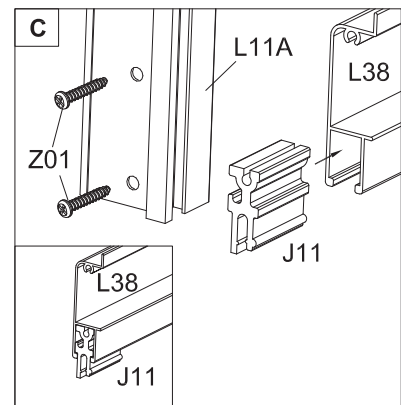
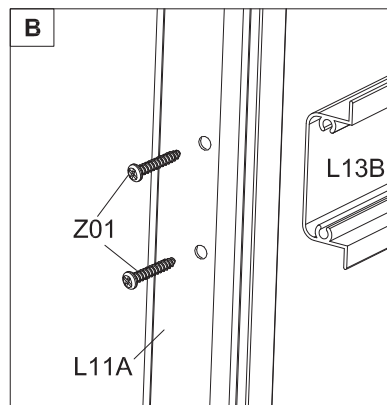
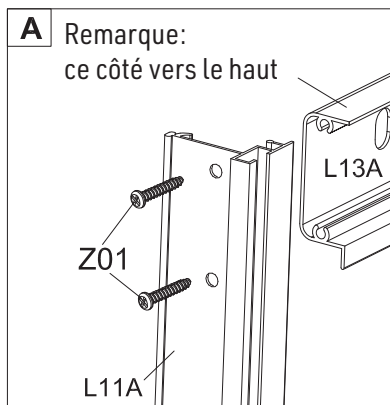
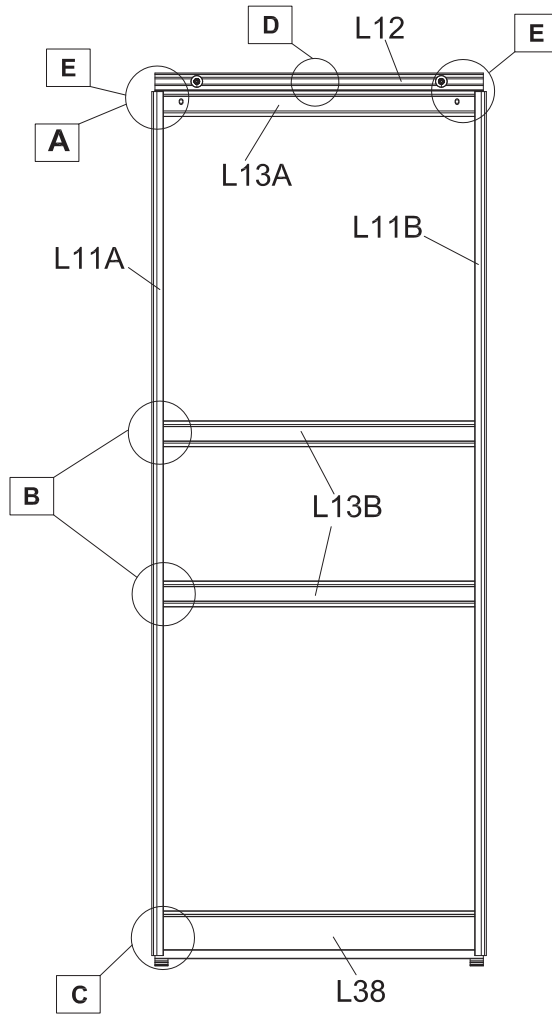

# Assemblage de la fenêtre

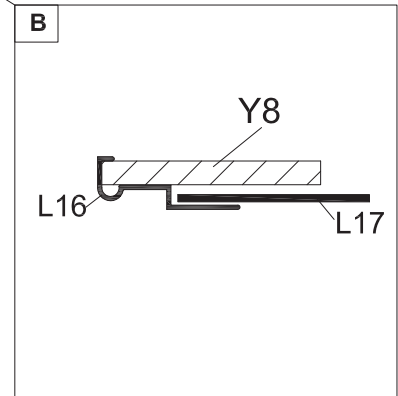
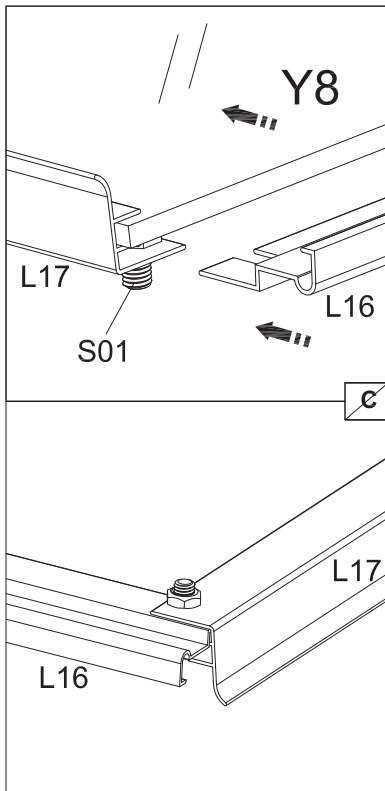
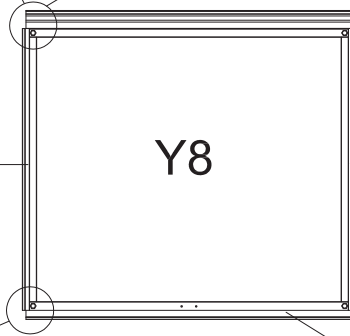
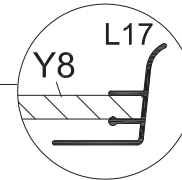
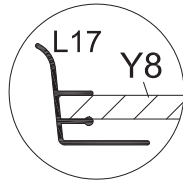
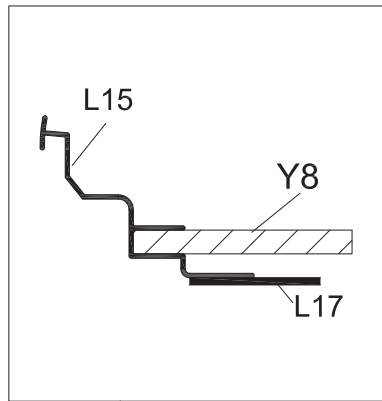
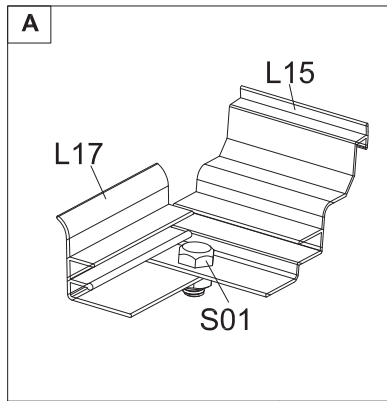

# Assemblage du pignon avant

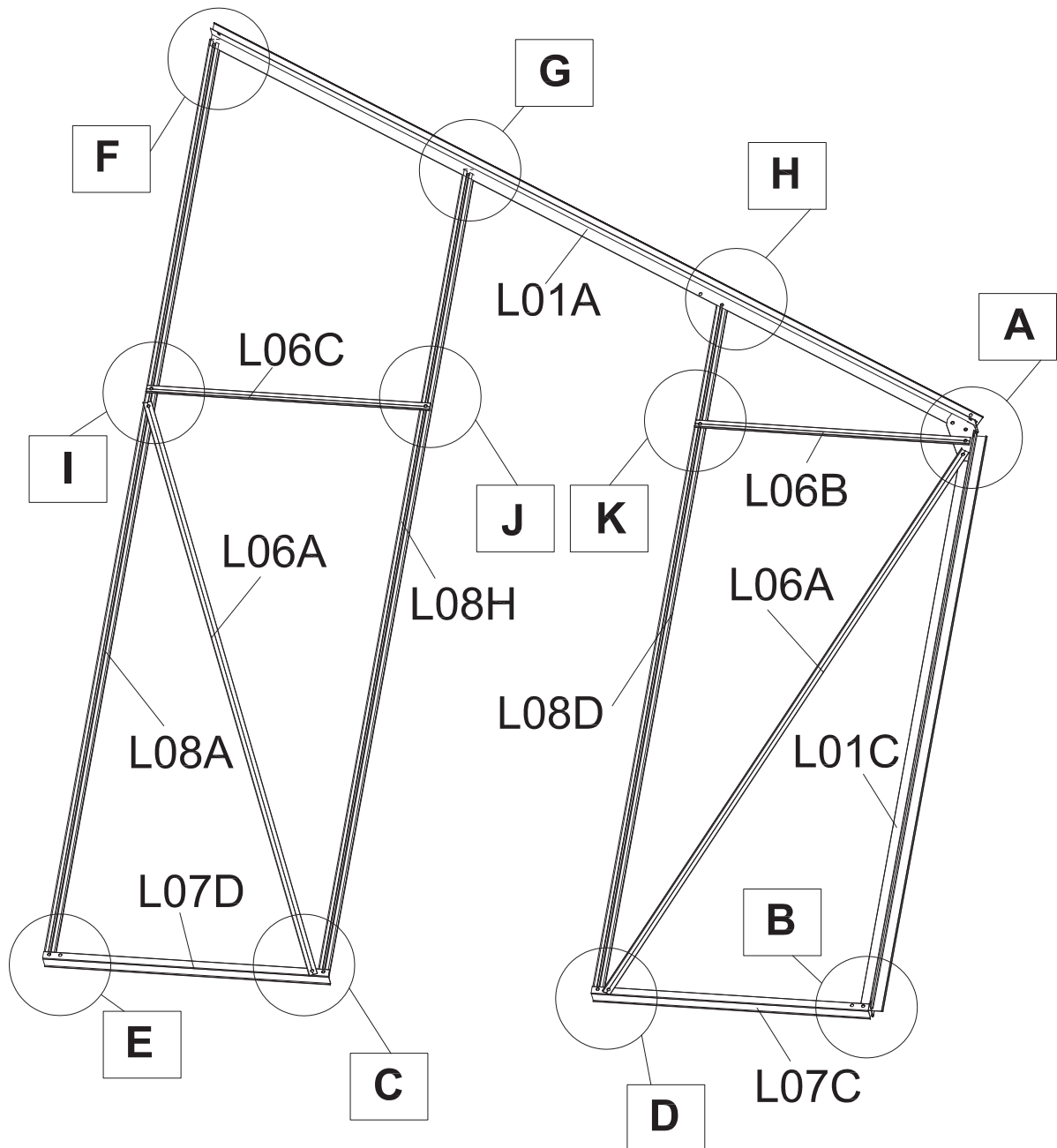

# Assemblage du pignon avant

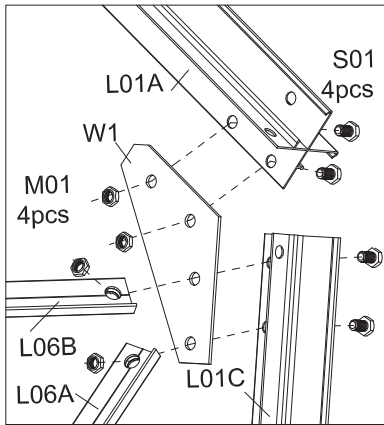

Ne pas serrer les écrous avant d'avoir assemblé L09

A

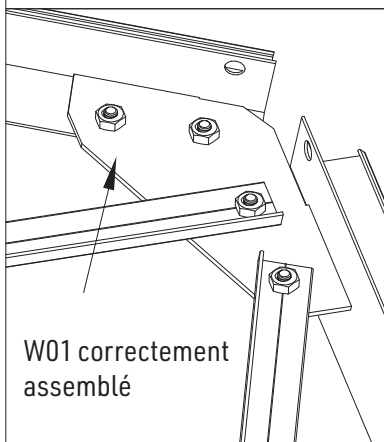

W01 correctement assemblé

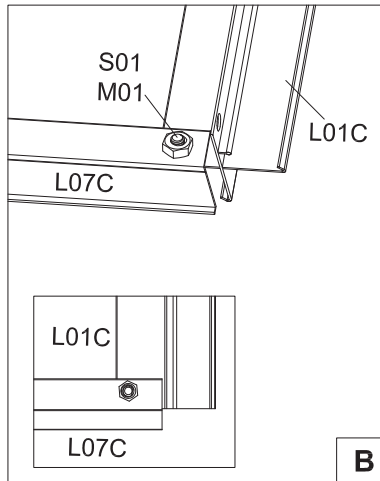

B

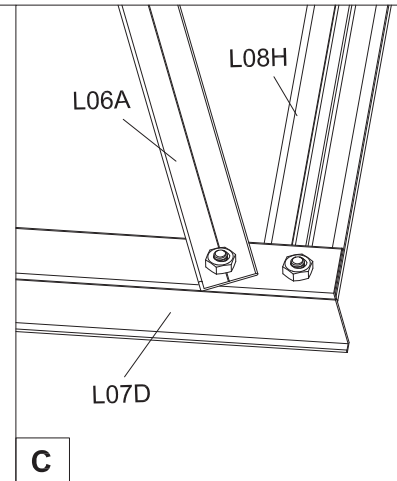

C

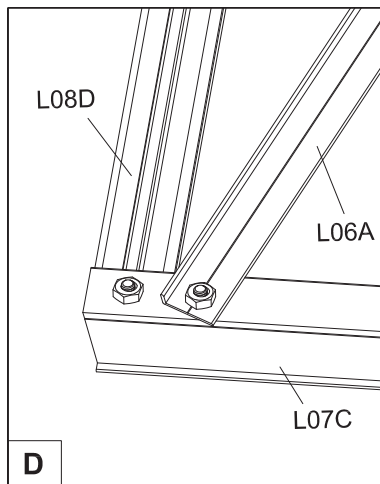

D

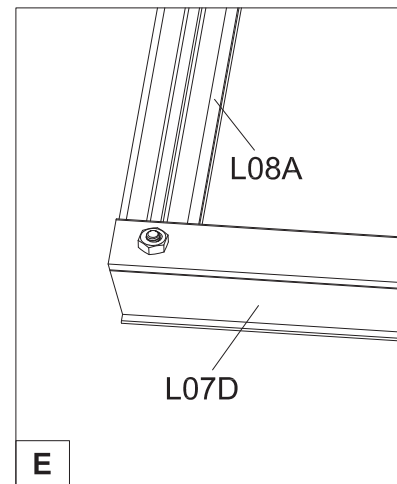

E

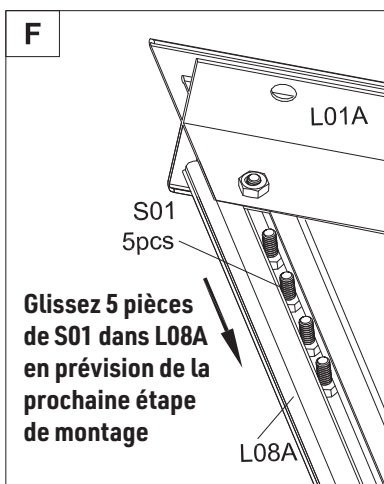

Glissez 5 pièces de S01 dans L08A en prévision de la prochaine étape de montage

F

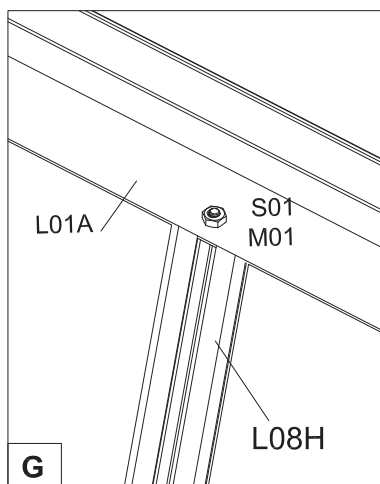

G

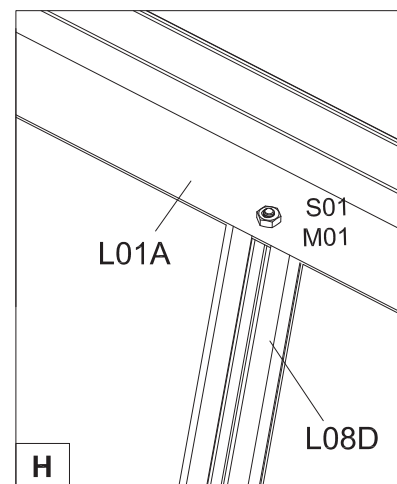

H

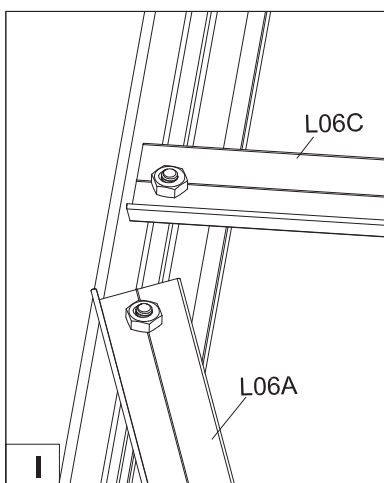

I

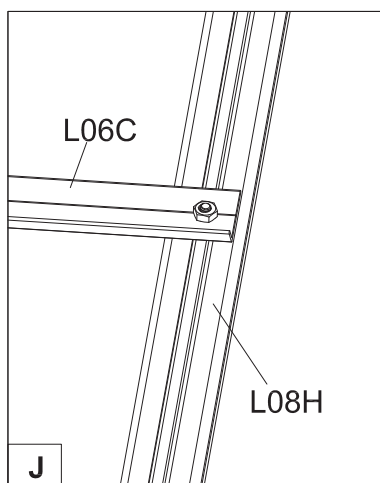

J

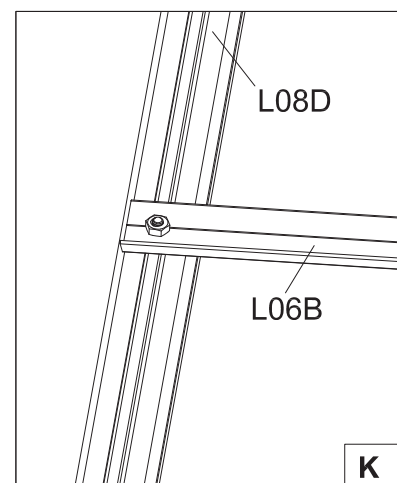

K

# Assemblage du pignon avant

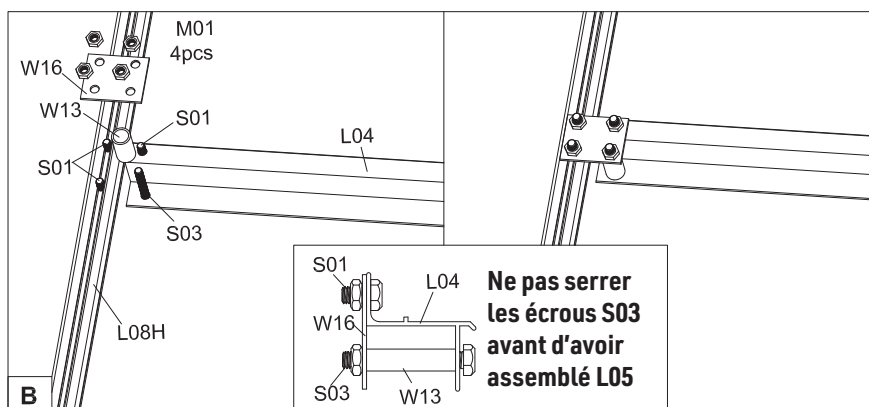
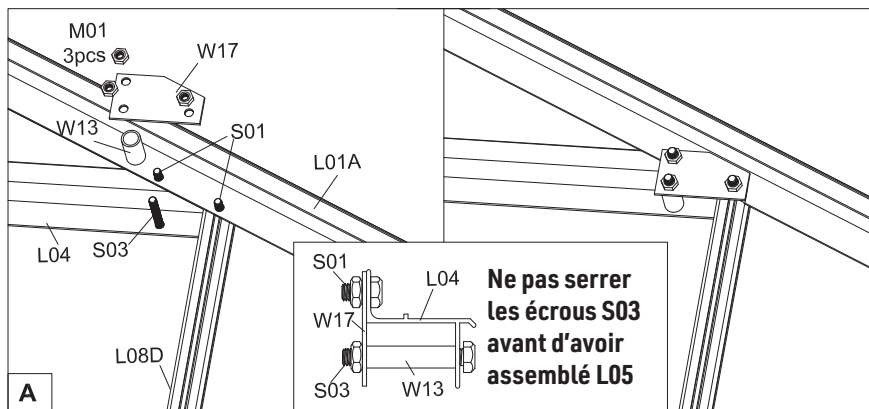
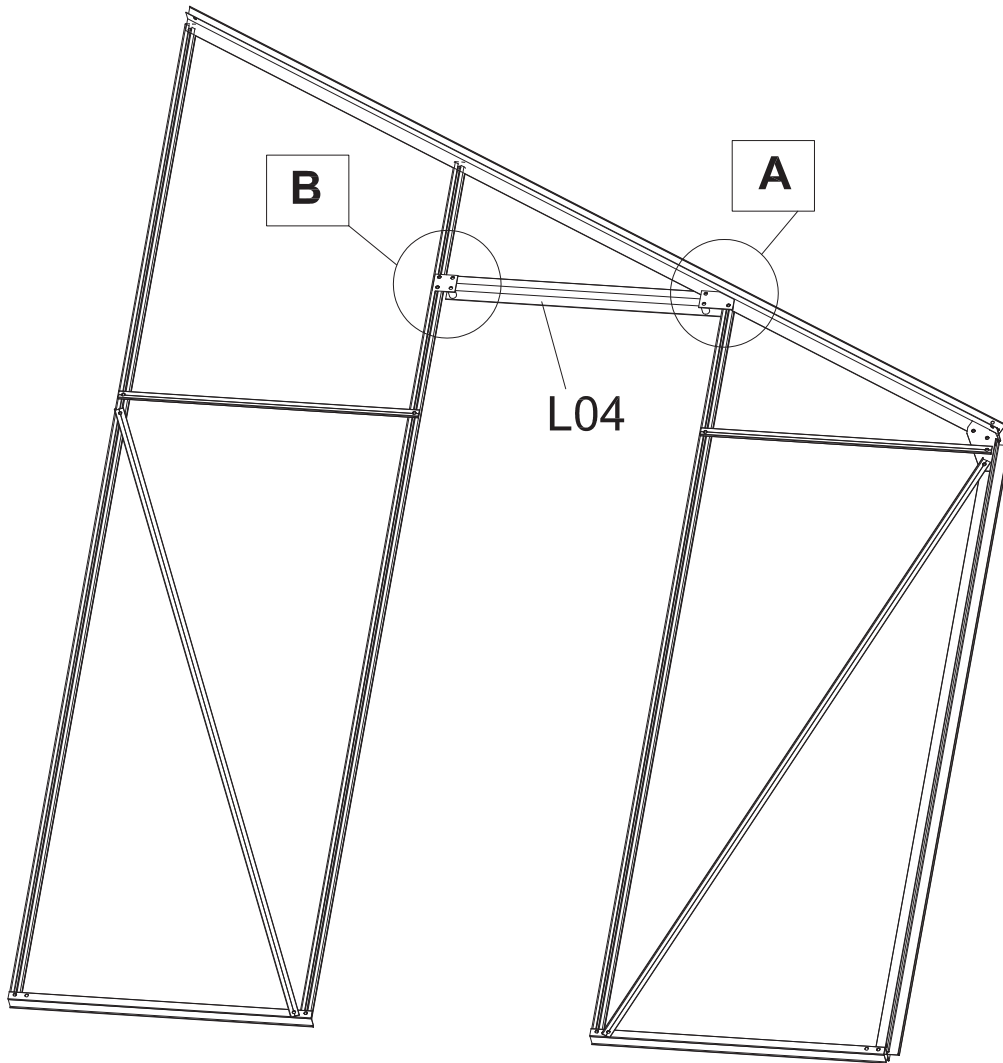

# Assemblage du pignon arrière

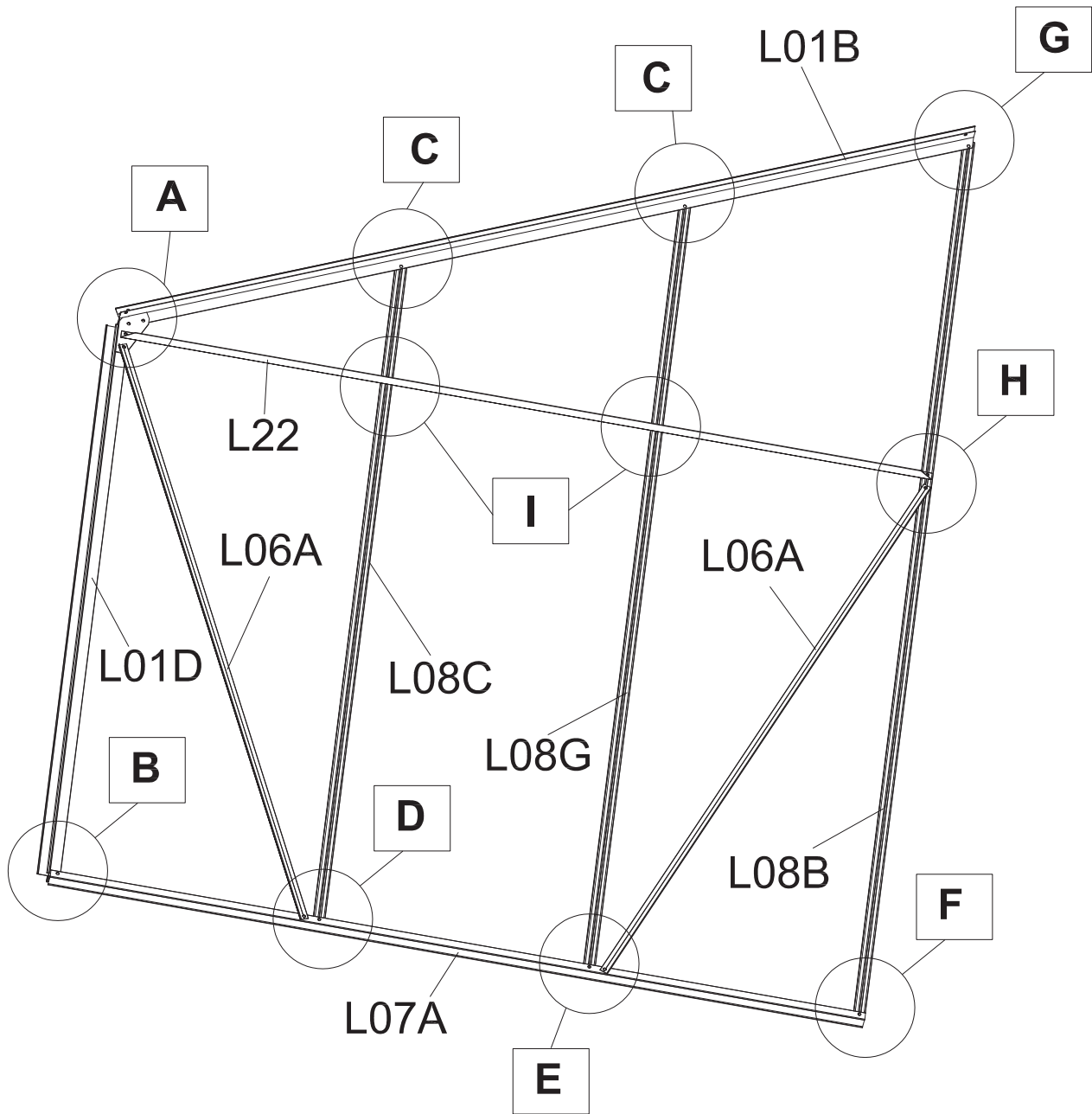

# Assemblage du pignon arrière

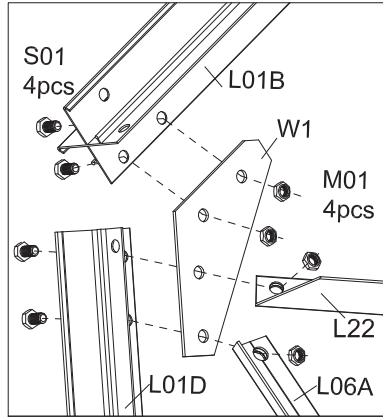

Ne pas serrer les écrous avant d'avoir assemblé L09

**A**

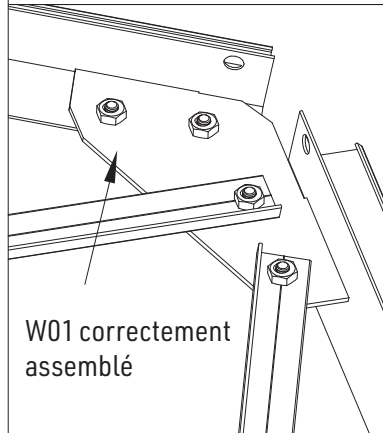

W01 correctement assemblé

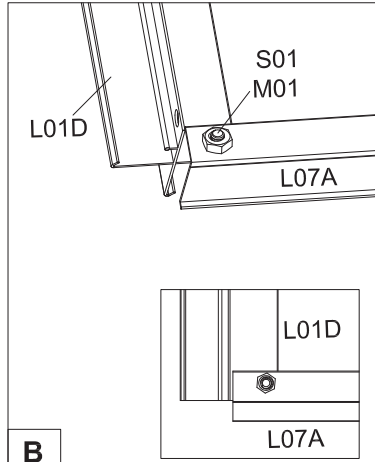

**B**

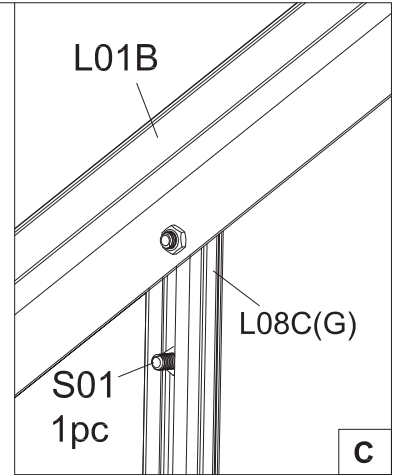

**C**

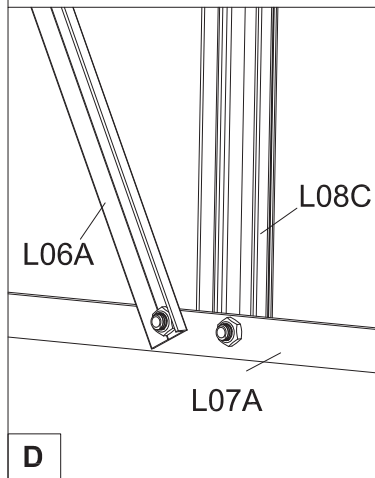

**D**

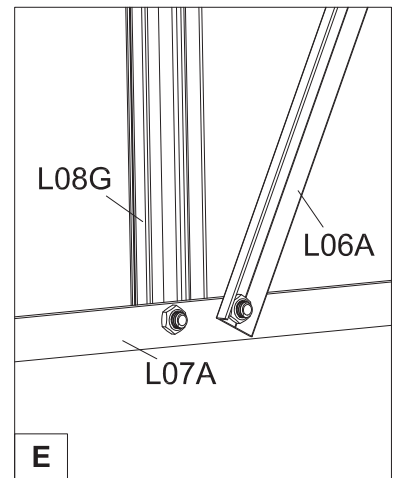

**E**

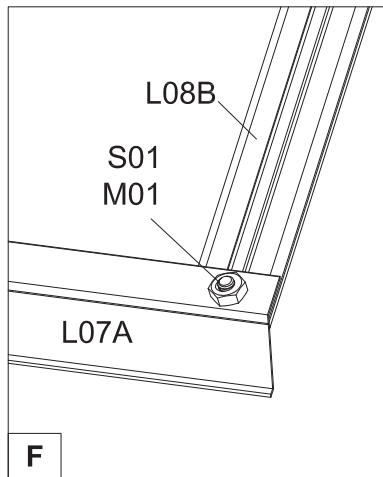

**F**

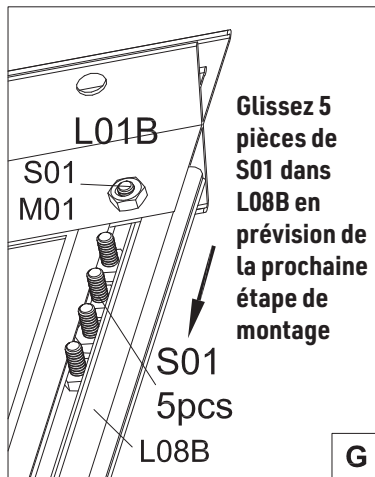

**G**

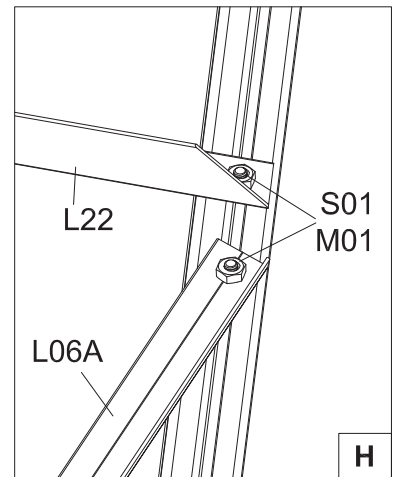

**H**

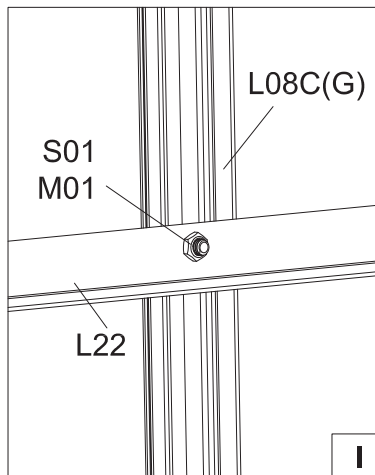

**I**



# Assemblage de la paroi latérale

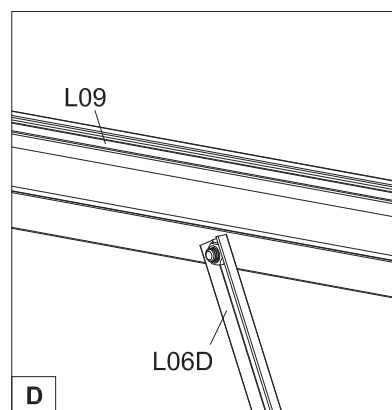
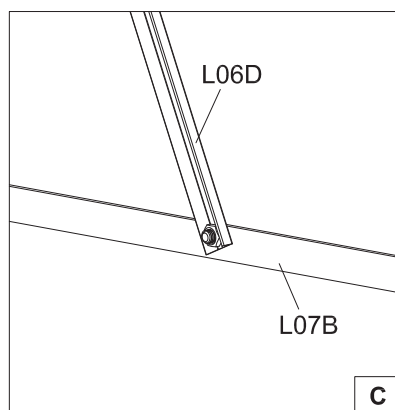
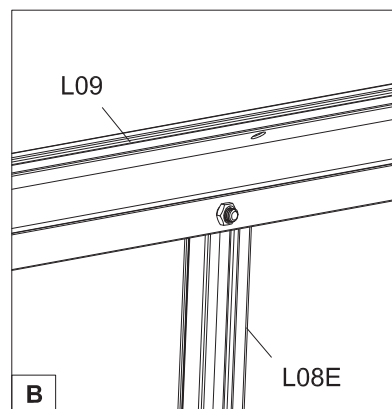
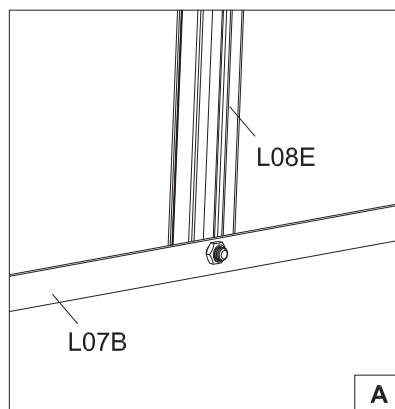
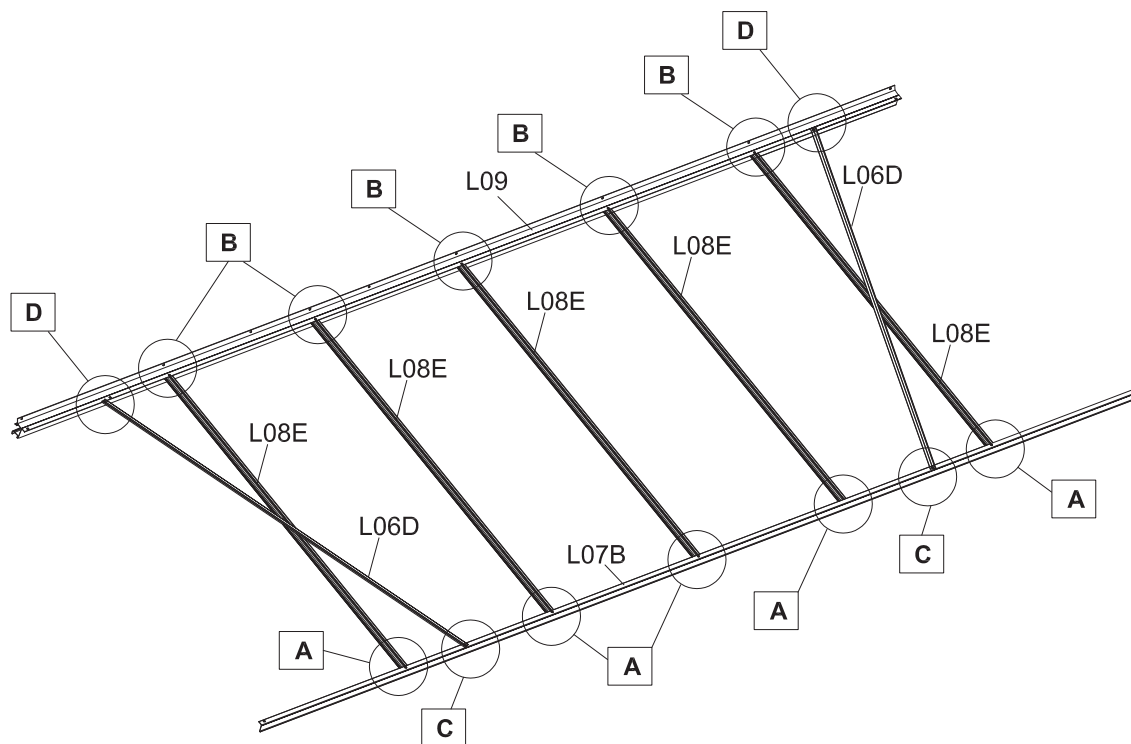

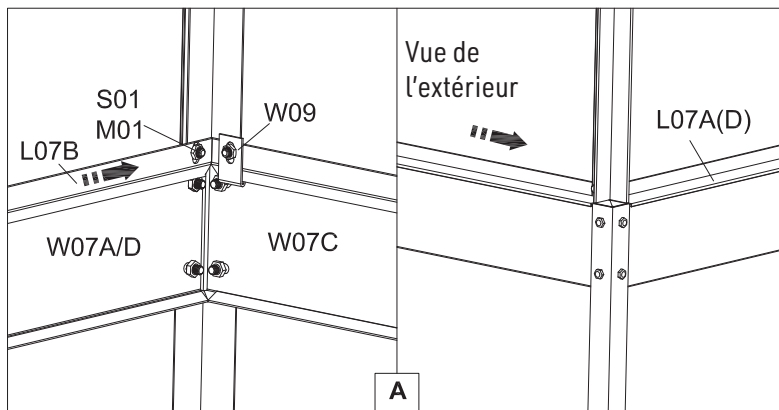
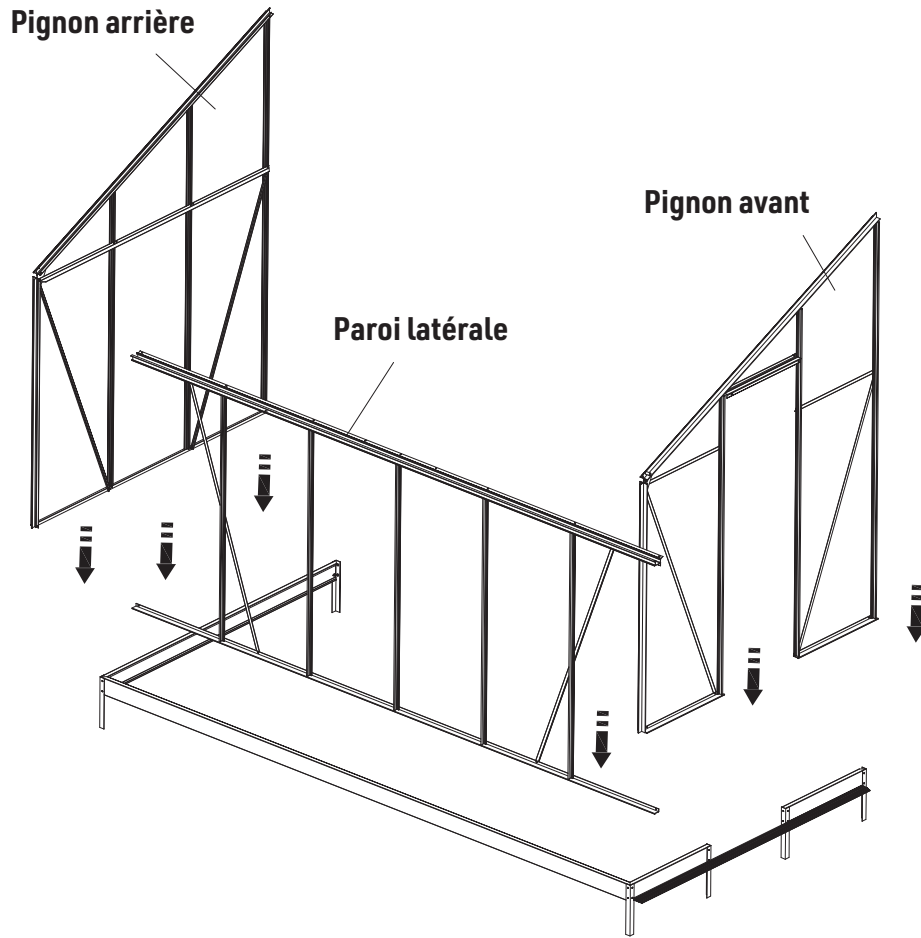

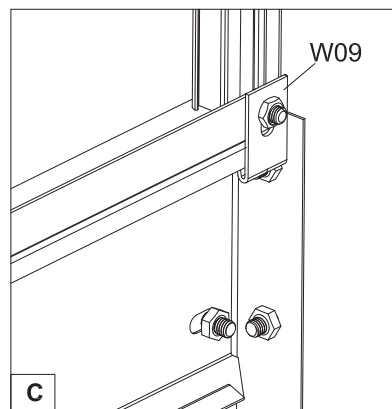
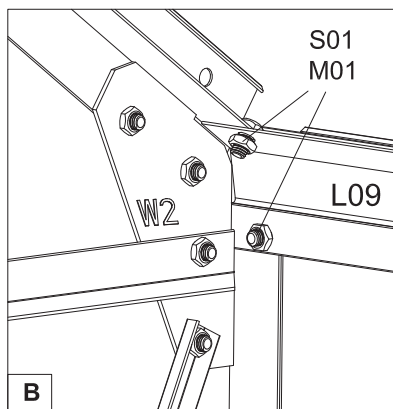
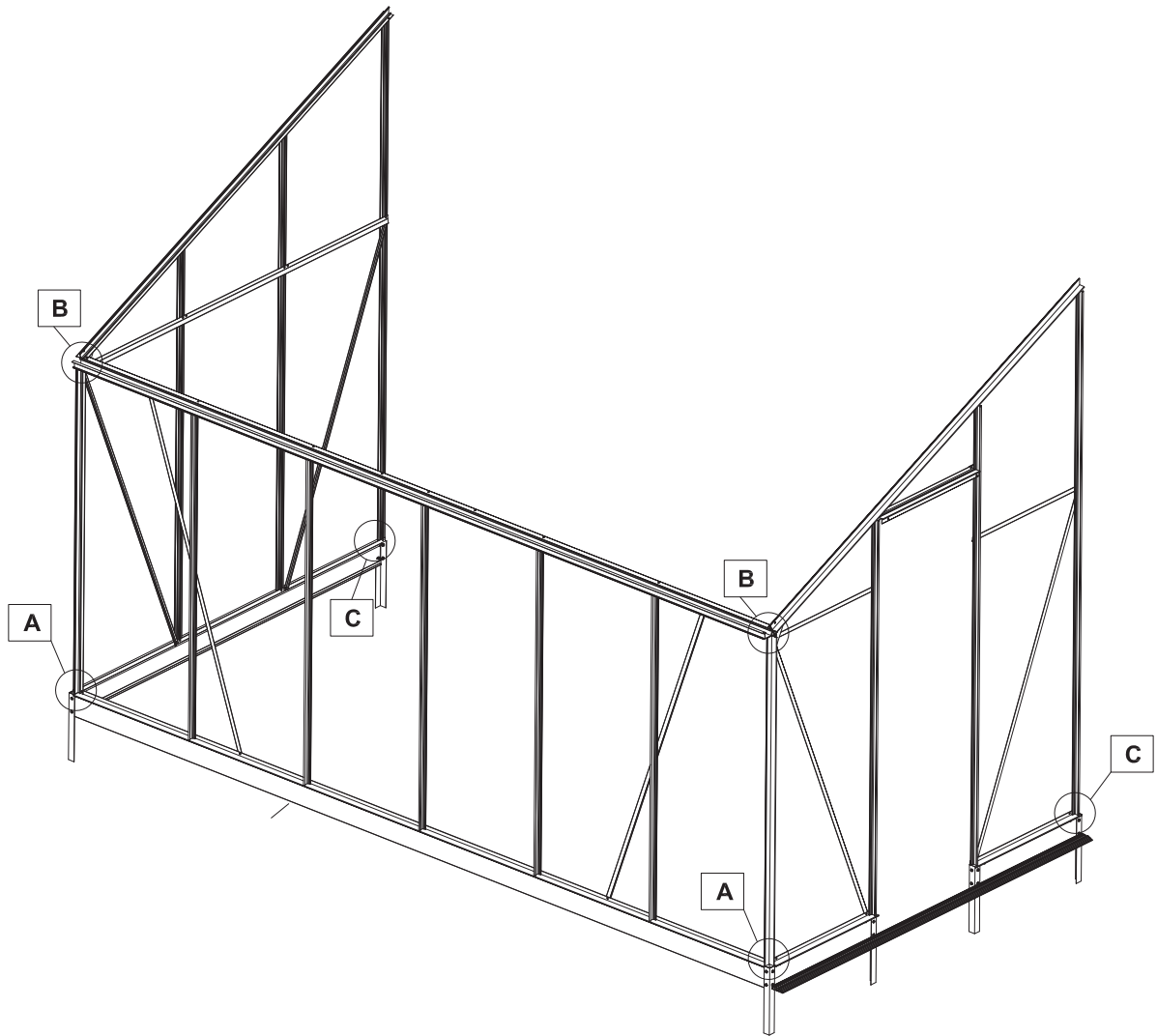

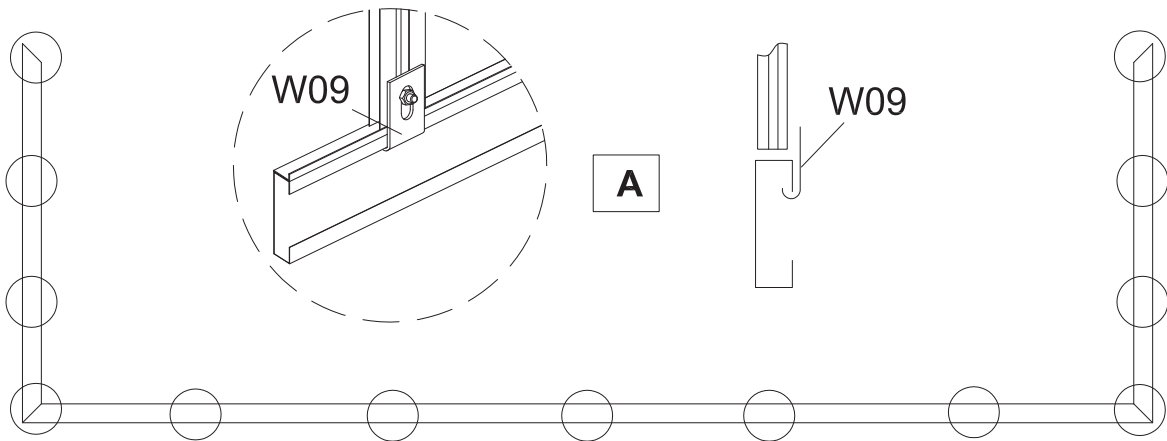
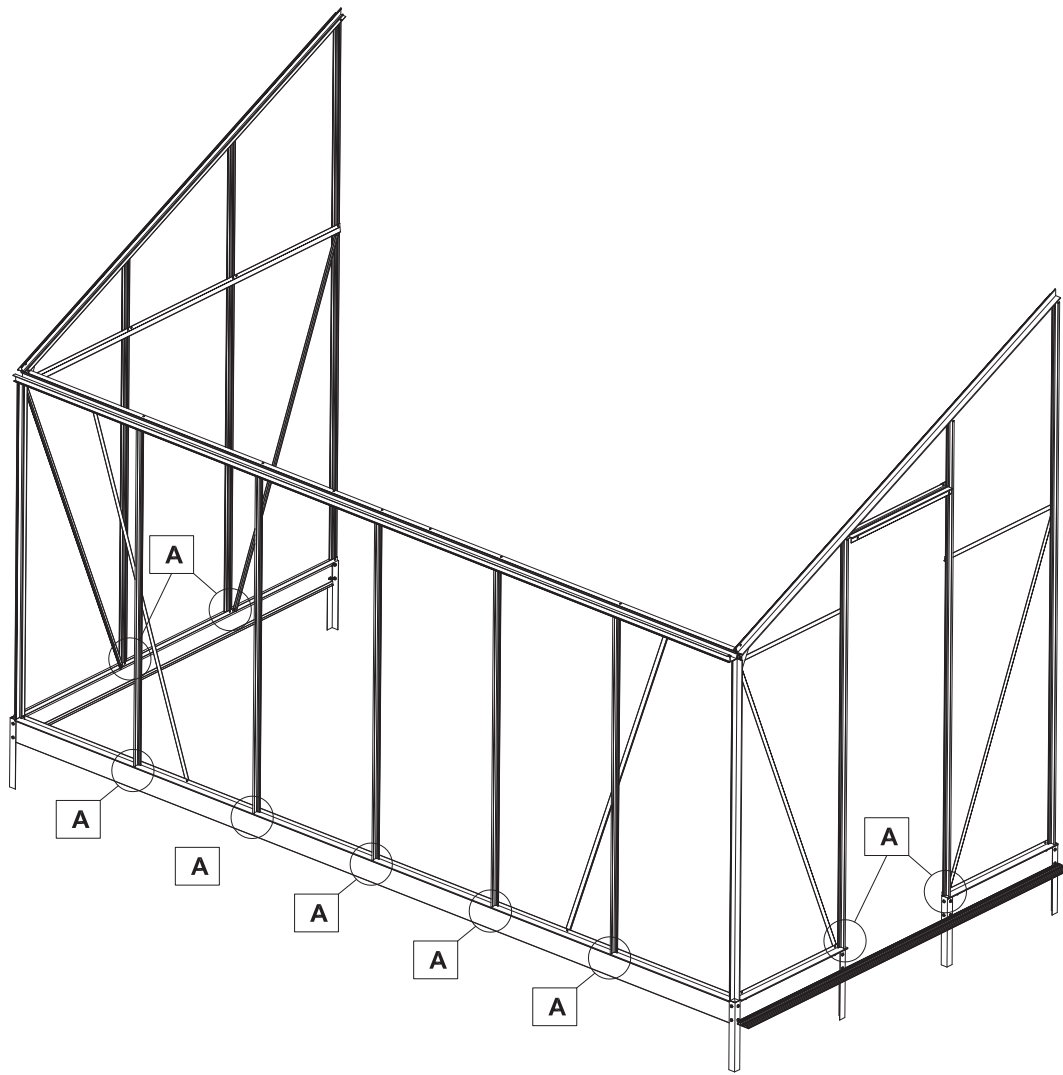

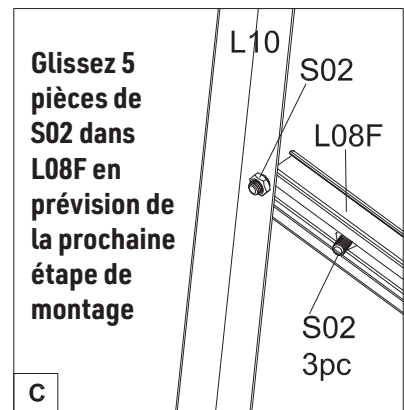
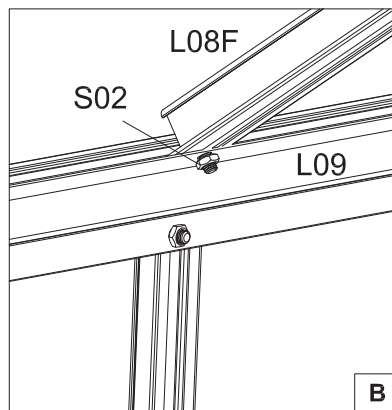
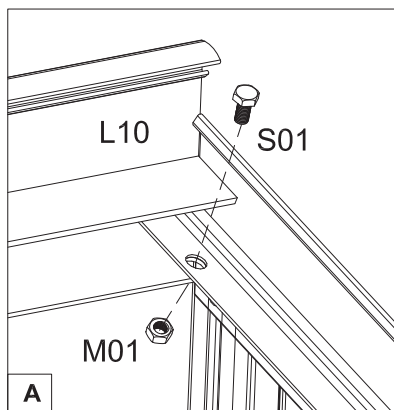
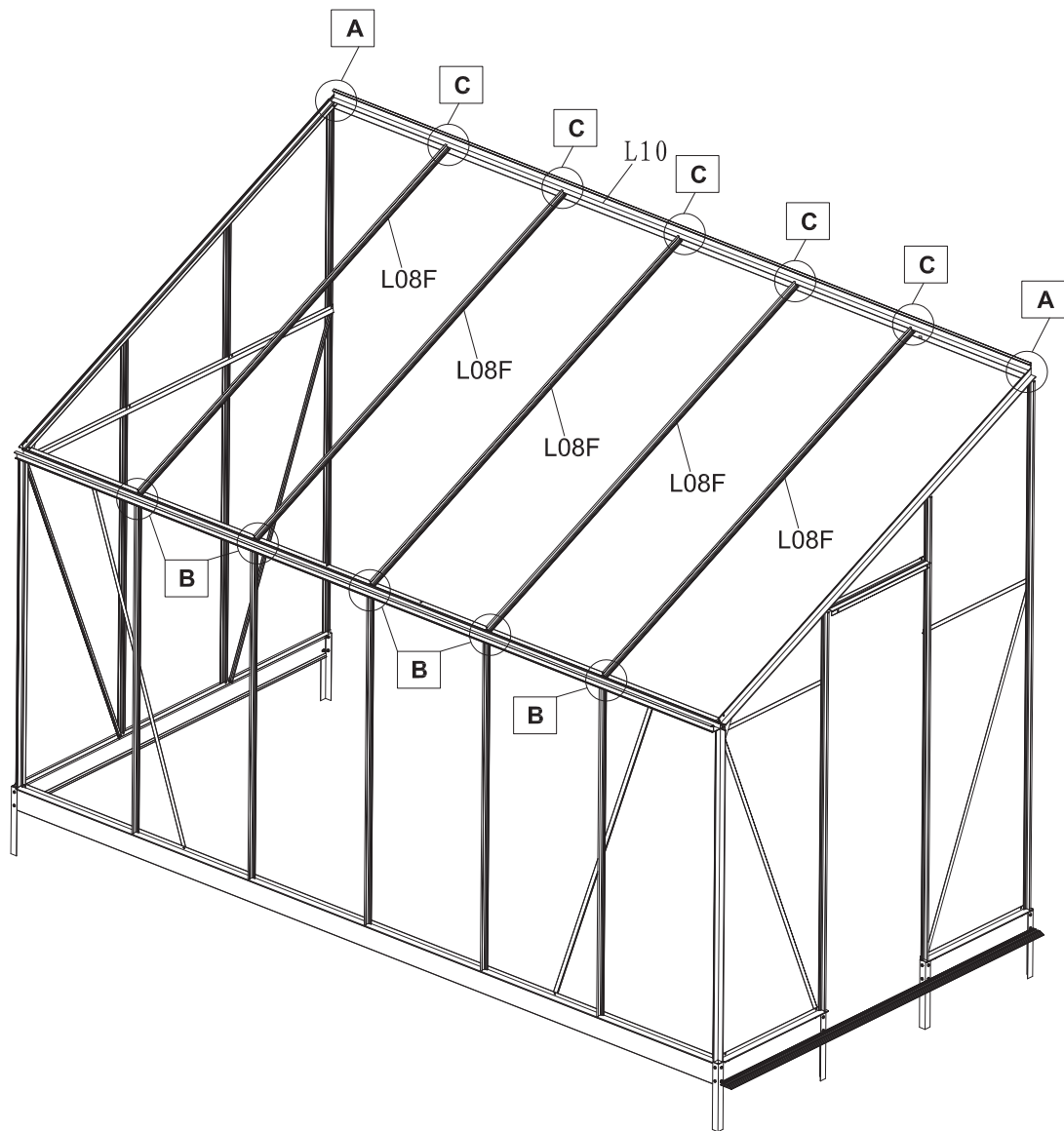

**Glissez 5 pièces de S02 dans L08F en prévision de la prochaine étape de montage**

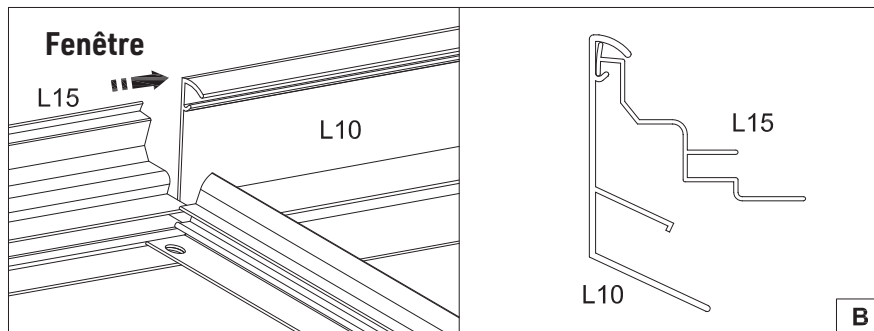
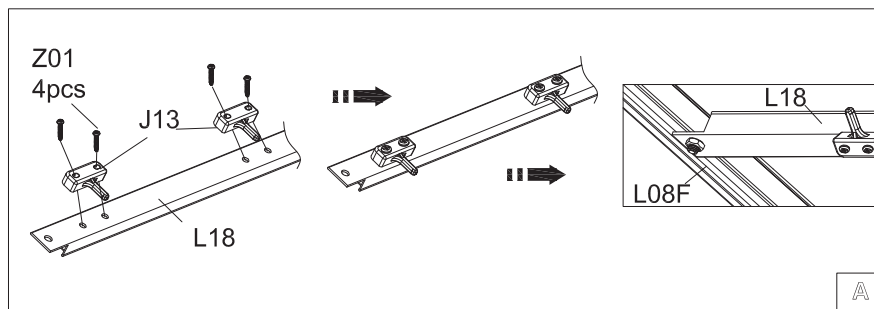
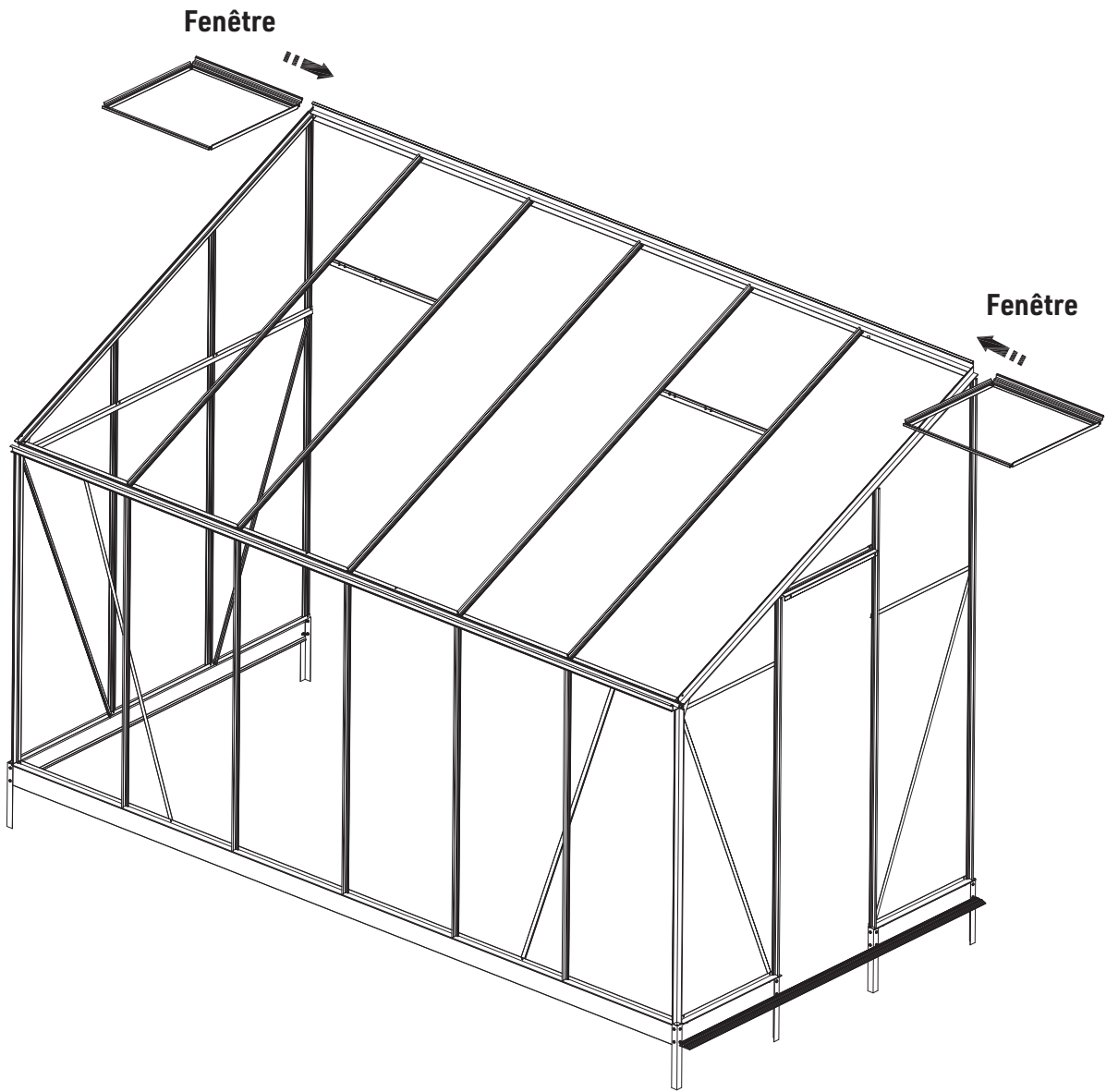

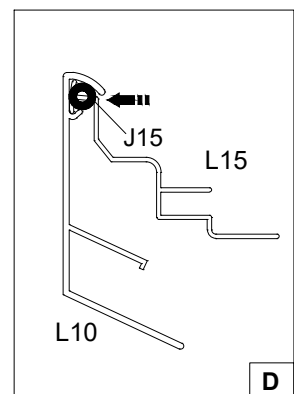
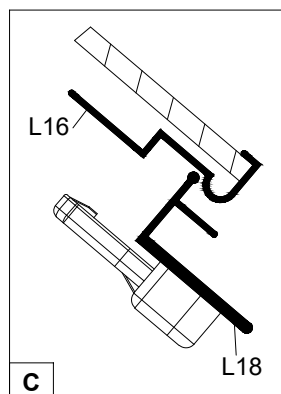
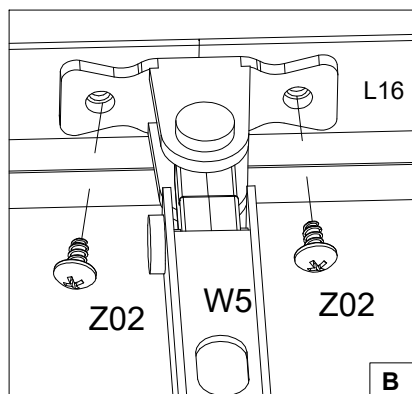
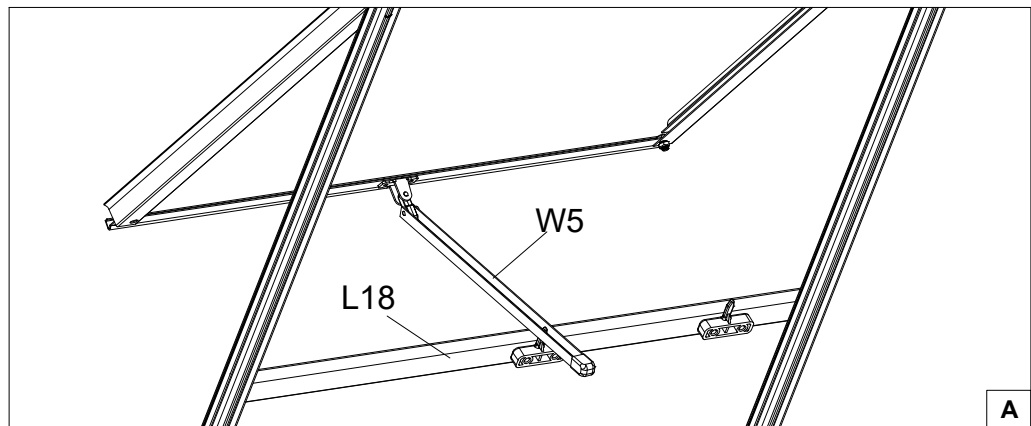
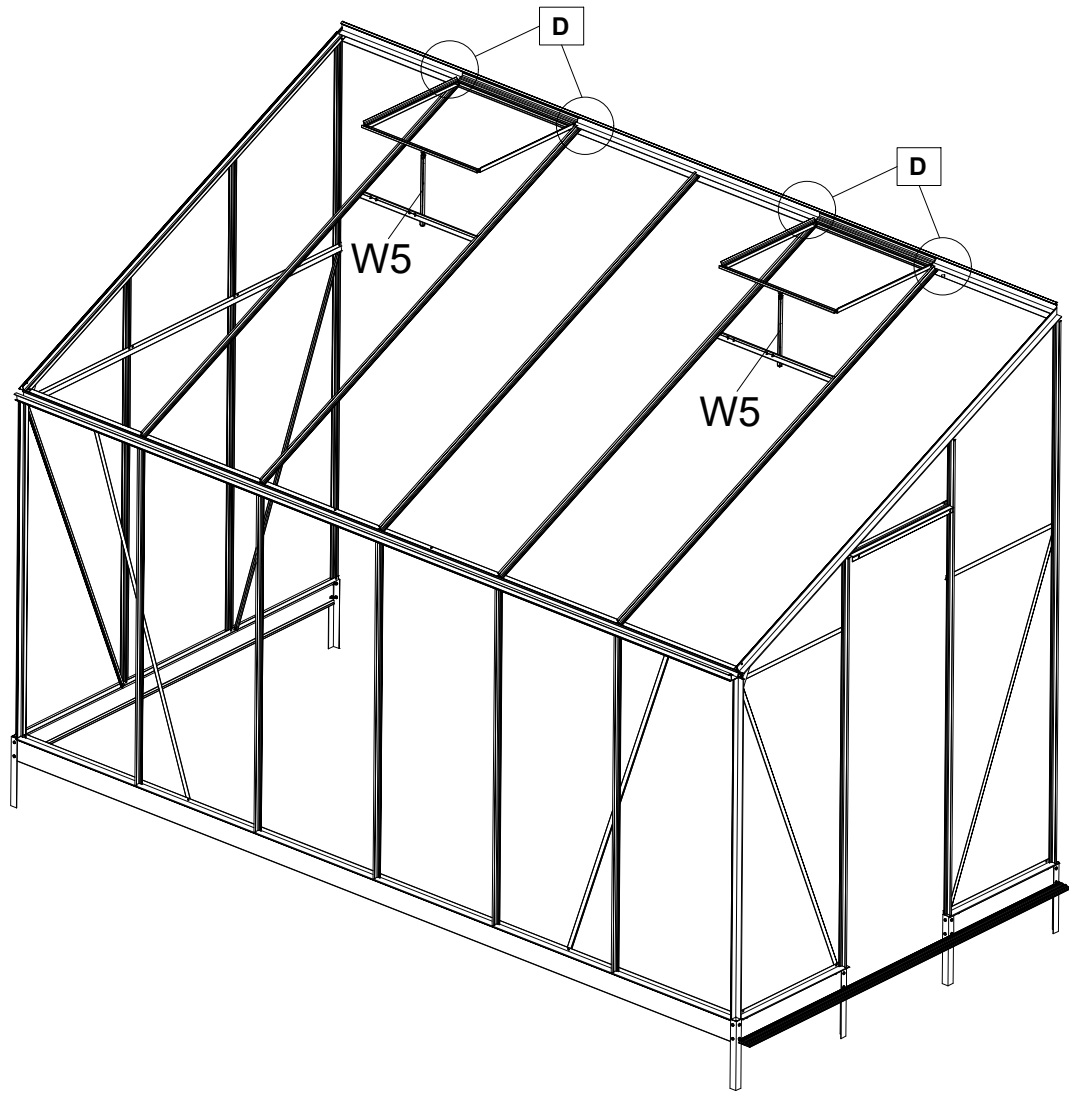

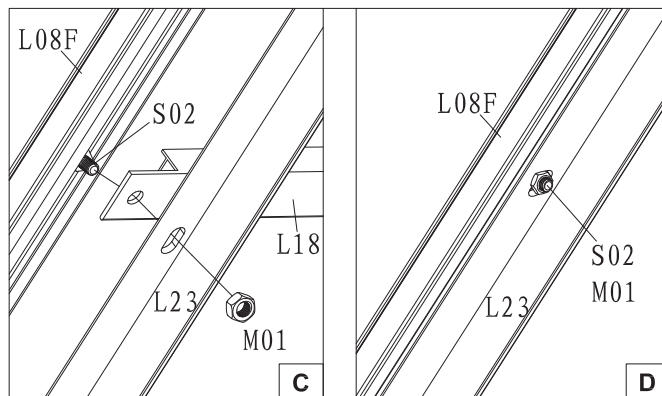
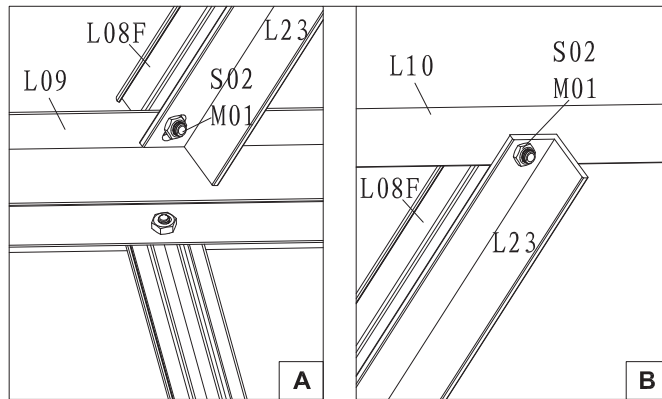
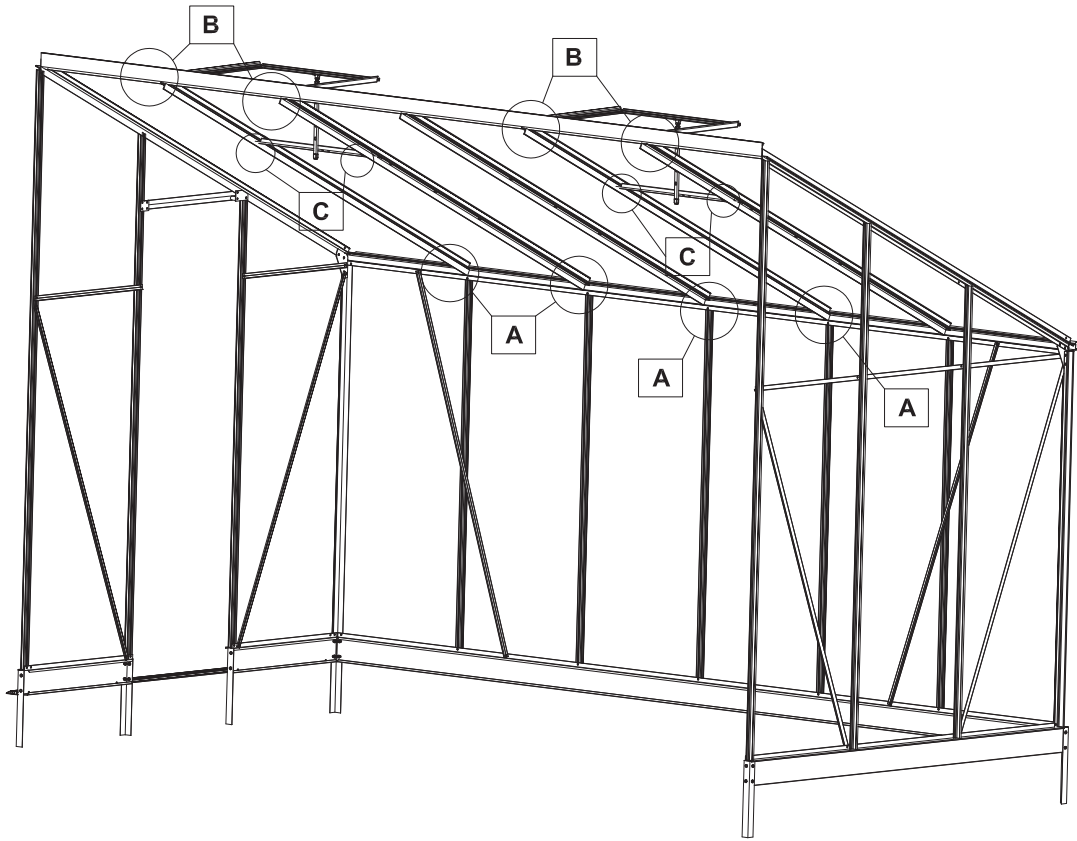

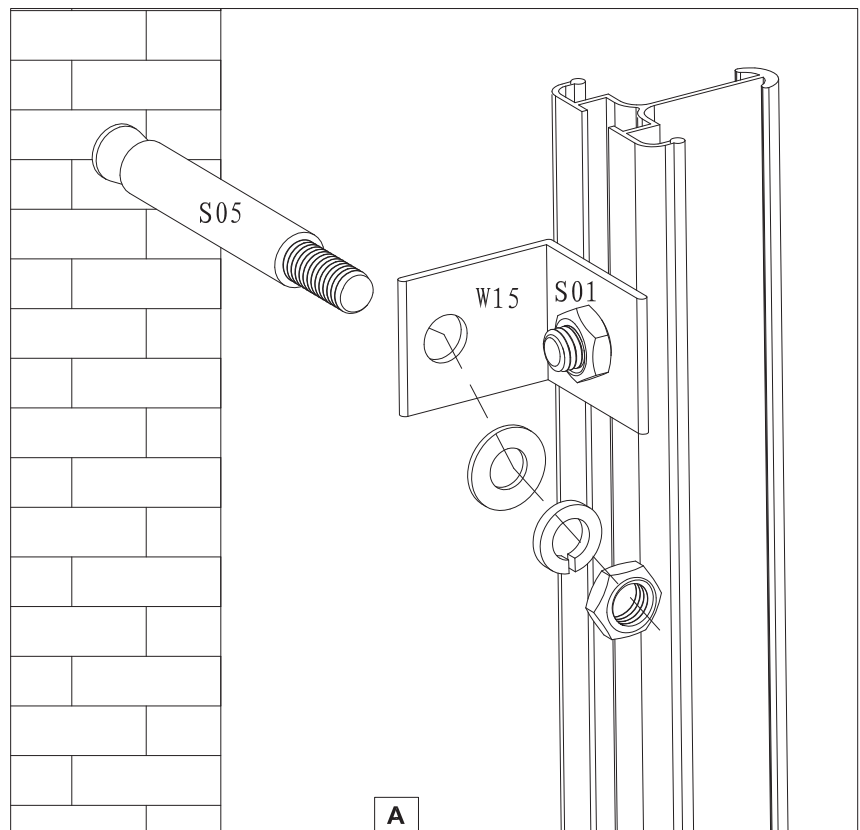
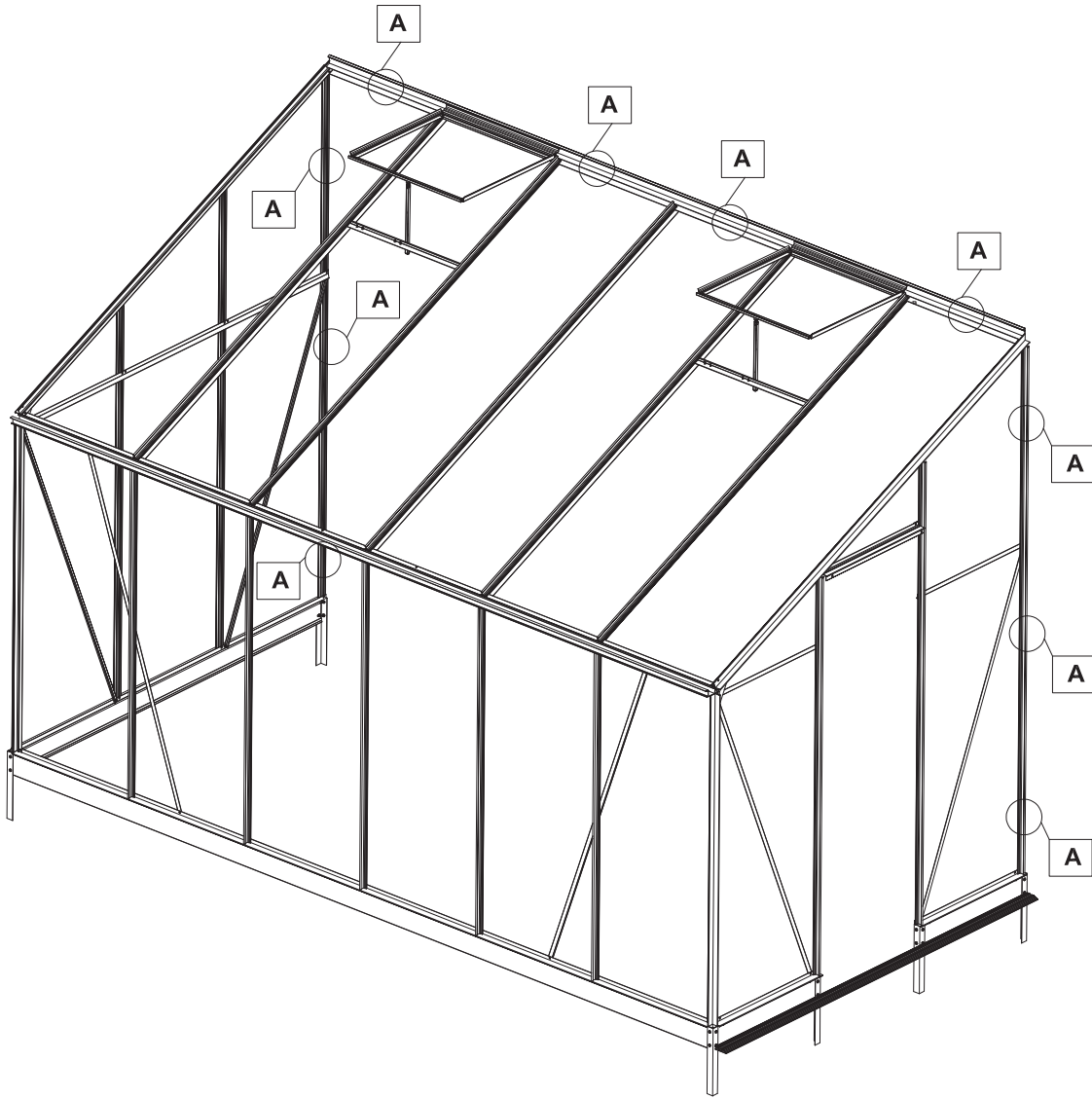

Pose du joint caoutchouc J19

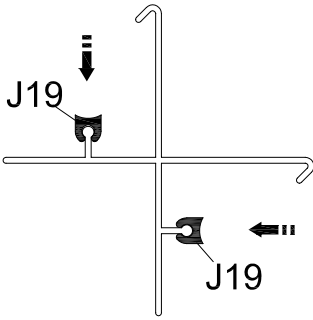

L01

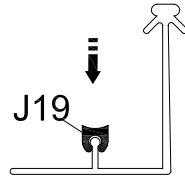

L03

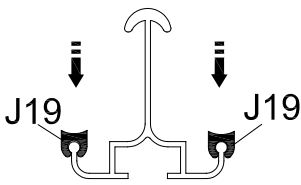

L08

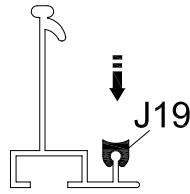

L11

Pose des verres

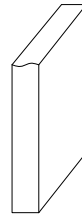
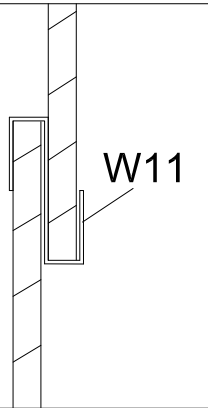
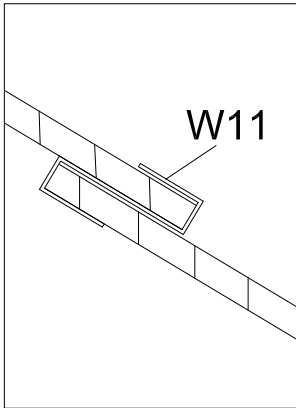
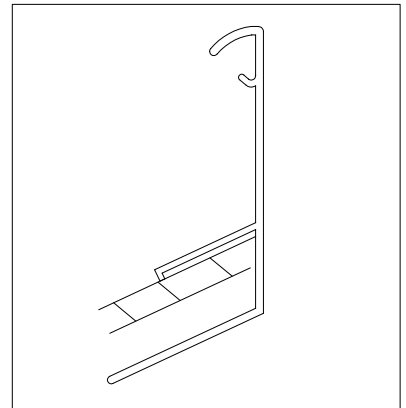
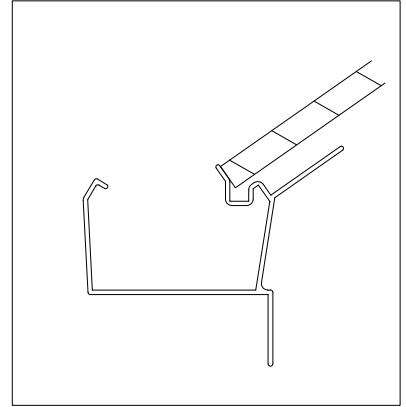

Faites attention à ne pas vous blesser en manipulant et en ajustant les verres

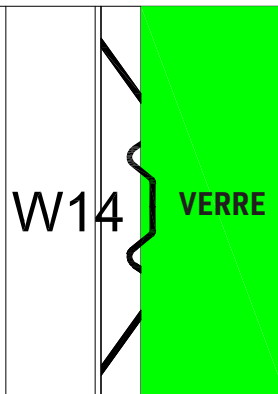
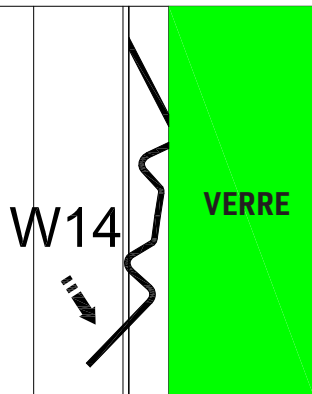
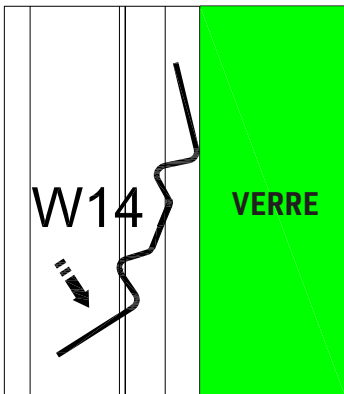
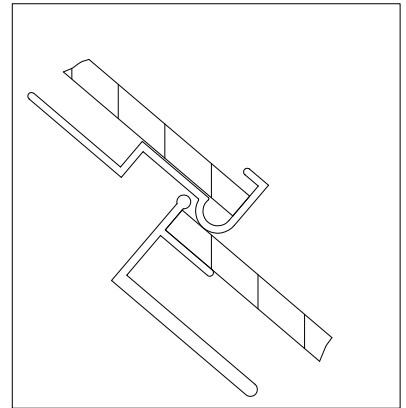

Faites attention à ne pas vous blesser en posant les clips W14

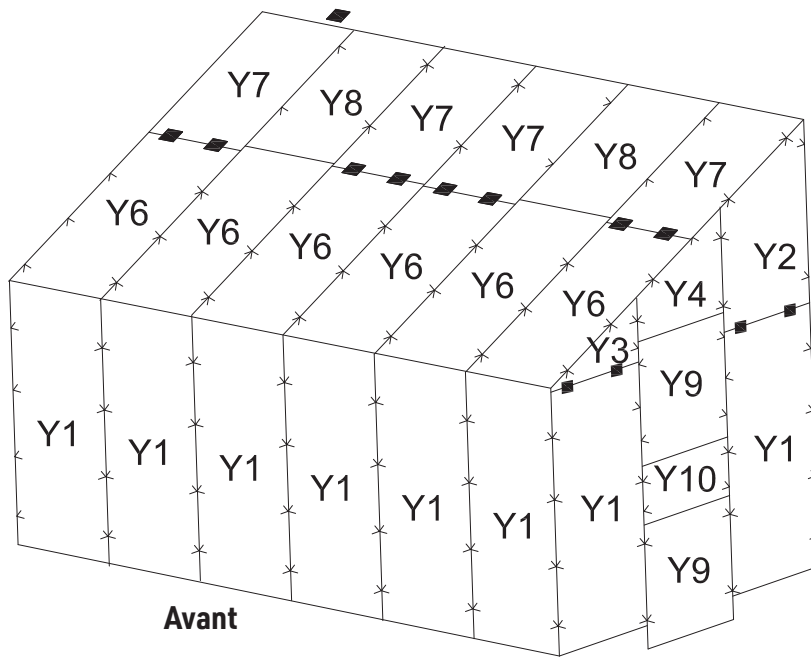

Avant

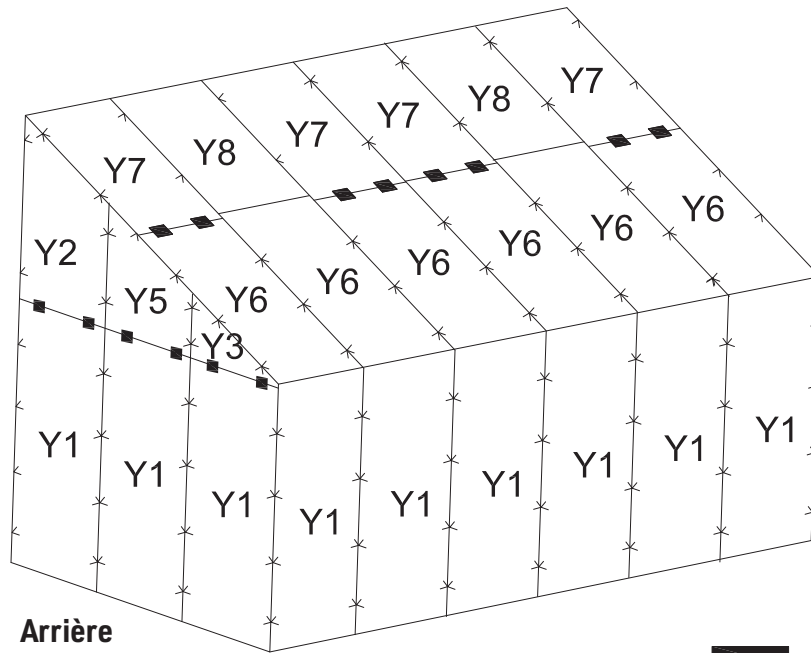

Arrière



Pièce	Réf	mm	Qté
	Y1	610x1472	11
	Y2	610x904x619	2
	Y3	610x326x41	2
	Y4	608x292x10	1
	Y5	610x616X330	1

Pièce	Réf	mm	Qté
	Y6	610x1338	6
	Y7	610x738	4
	Y8	602x726	2
	Y9	629x609	2
	Y10	629x395	1

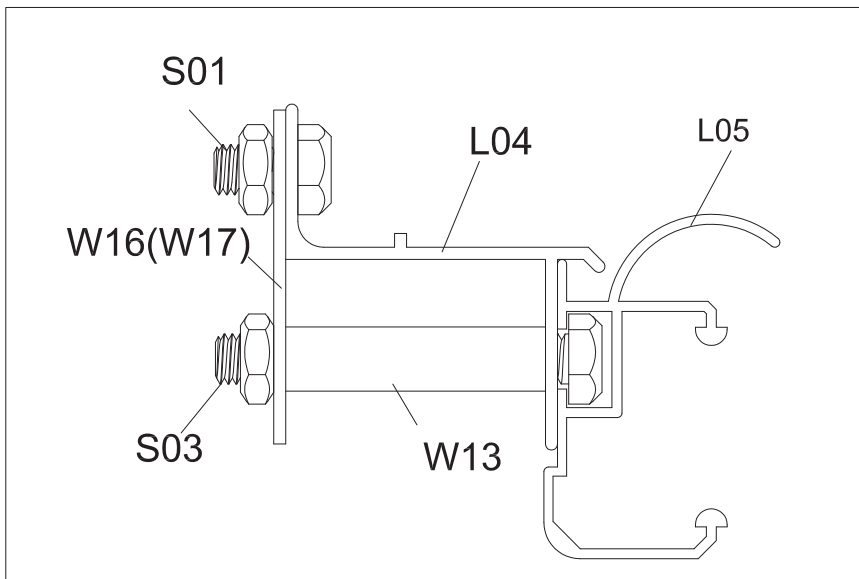
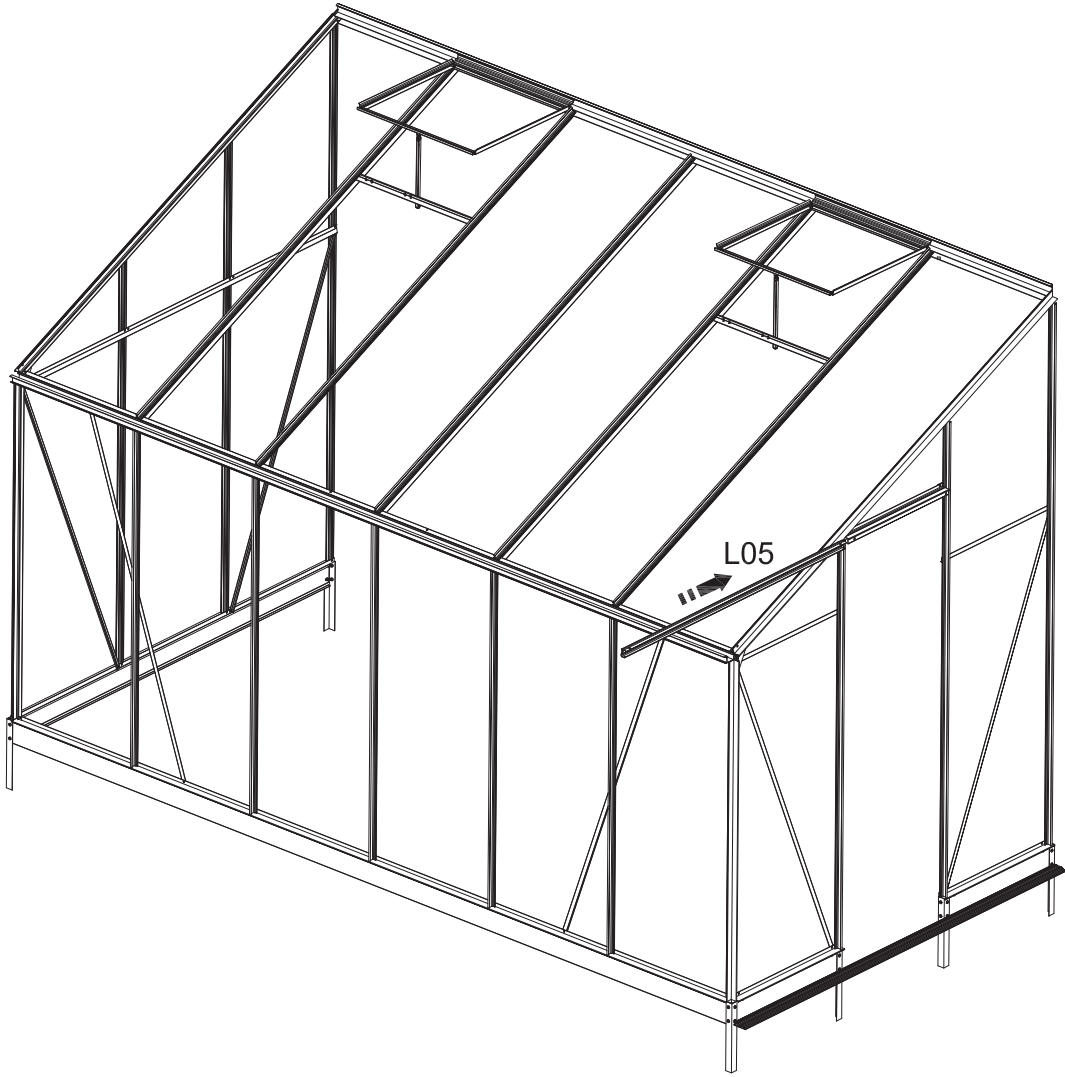

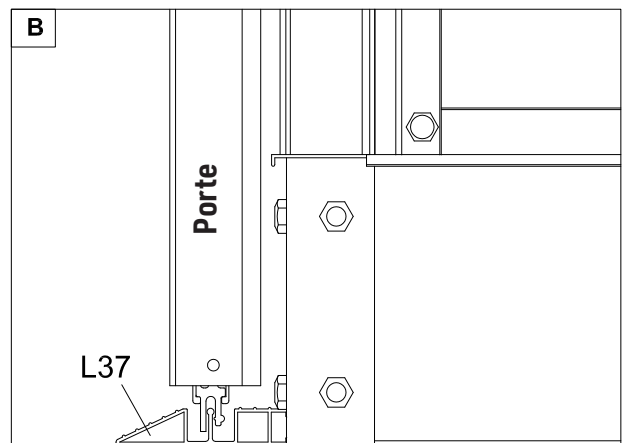
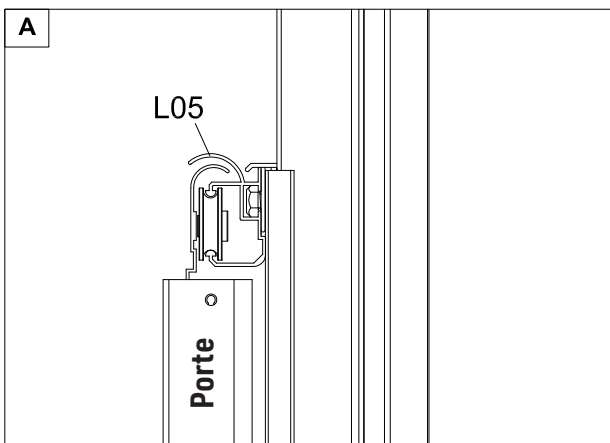
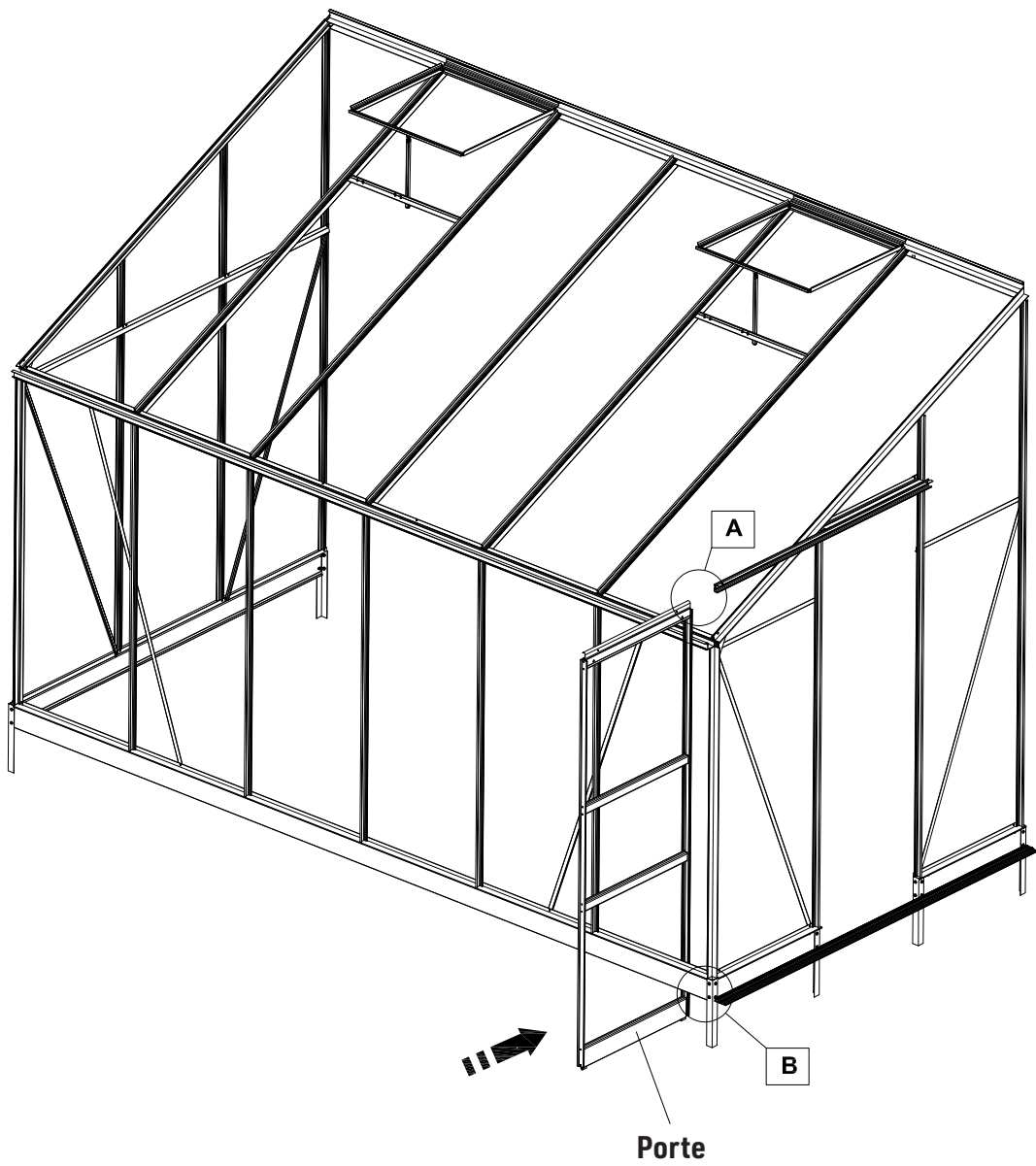

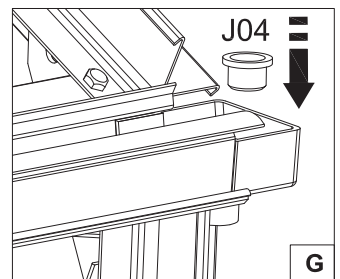
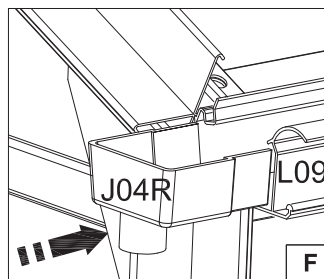
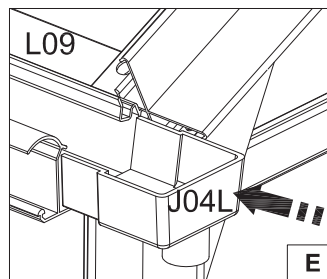
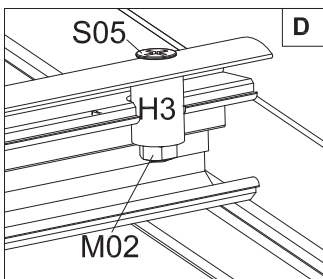
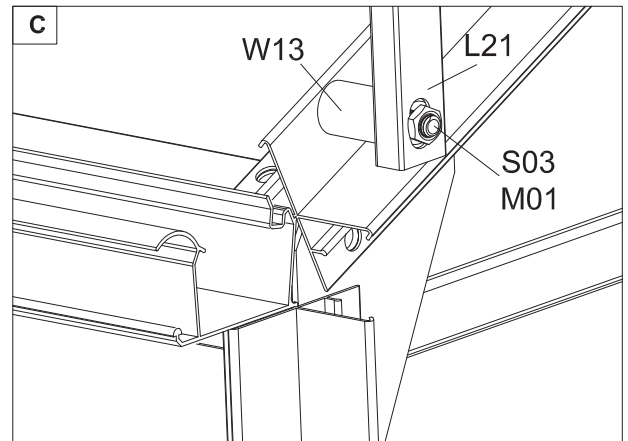
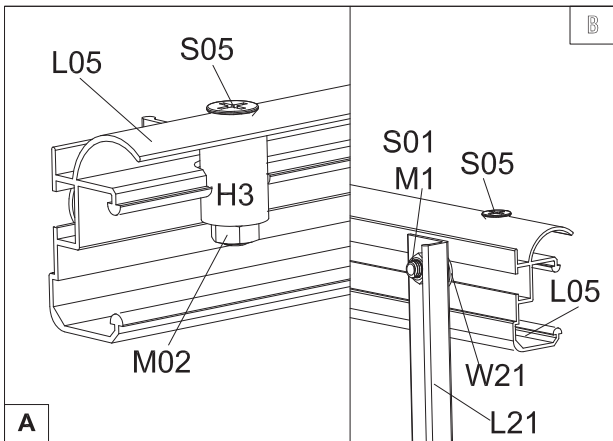
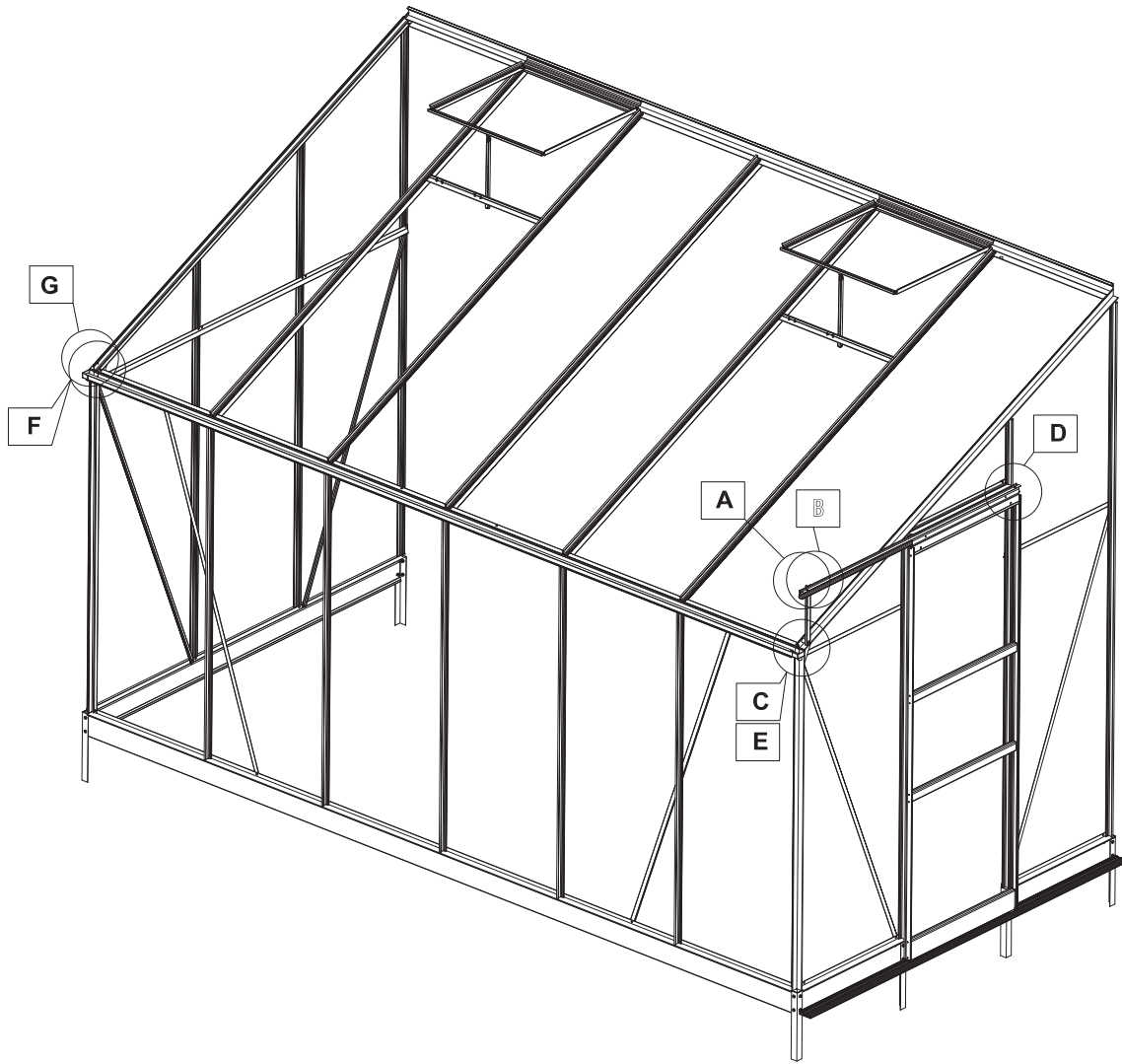

Dear customer

Congratulations on the purchase of your new garden greenhouse. Please read the following instructions carefully before proceeding with the assembly.

**Please note: before starting the construction of your greenhouse, take the necessary time to identify all possible hazards such as buried or overhead cables or pipes, etc...**



### Installation location

- ☑ A sunny, open, north-facing location, protected from strong winds, is the most suitable place to get the best results from your greenhouse.
- ☑ The greenhouse should be placed on a flat, level surface. There are several options for preparing the foundation of the greenhouse to suit your needs. Greenhouses come with a base to meet most mounting needs.
- ☑ Access to water and electrical supply outlets should be considered early in the installation process, before laying solid foundations. It is recommended that sufficient clearance be provided around the greenhouse, both during installation and for later maintenance.

### Setting up



- ☑ Assemble the aluminum frame (without the glazing) and position it in the installation area, so that you can dig your holes for the foundation. This will allow you to locate and mark the exact position of the post holes for anchoring.
- ☑ Once you have marked your anchor positions, move the greenhouse frame to allow the holes to be dug.
- ☑ A minimum depth of 60cm and a diameter of 20cm are recommended. Once the anchor stakes are attached to the base and brackets, you can lift the greenhouse over the holes and lower it to ground level.
- ☑ Once you are satisfied with the final position and have ensured that the frame is square, level and flat, you can proceed to pour concrete in the holes and thus fix the greenhouse permanently to the ground.







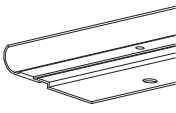
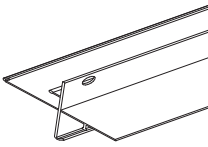
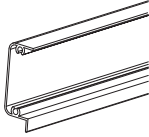
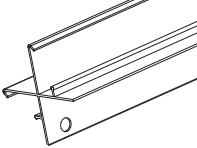
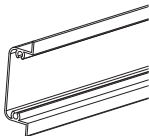
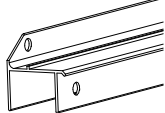
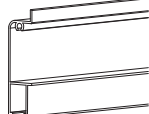
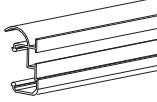
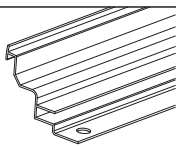
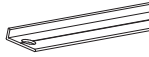
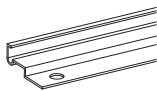
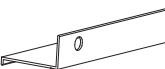
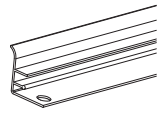
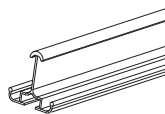
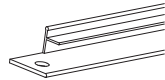
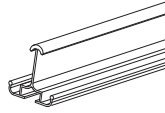
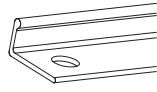
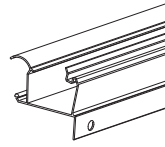
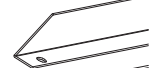
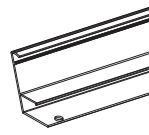

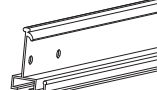

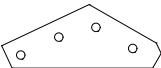

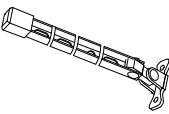



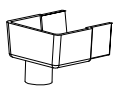

### Fixing to a solid base

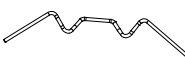
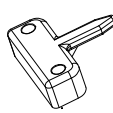
- ☑ Use the base plan provided with the instruction manual as a guide to build your solid base, whether it is made of wood, brick, concrete, ...
- ☑ The parts suitable for fixing the greenhouse to the ground are located within the aluminium base at approximately 55 mm to 43 mm.

### Glazing

- ☑ Once the aluminium frame has been installed, you can proceed with the installation of the glazing.
- ☑ Although all glass is tempered safety glass, it should always be considered dangerous and handled with care.
- ☑ Make sure the frame is free of debris before you begin. Beware of wind.
- ☑ If you are placing panels next to the greenhouse during construction, a slanted position is recommended.
- ☑ Start with the roof panels and work from end to end.
- ☑ To insert the roof panels, lean against the gutters and slide them between the rebar until they reach the ridge and fit.
- ☑ Slide the wall panels by tilting them between the vertical aluminum bars, push them up and into the rebate under the gutter.
- ☑ Make sure the bottom of the glass panel rests properly on the top of the base.
- ☑ The panel will look perpendicular and vertical and will be secured by a groove at the bottom and a rebate at the top.
- ☑ Insert the rubber gaskets using your thumb and forefinger as a guide.
- ☑ All rubbers are made longer than necessary and must be cut once adjusted.
- ☑ If the rubber extrusion looks dry, use soapy water to help install it into the glazing bar.
- ☑ The gaskets should look flat and straight when completed.
- ☑ Leave the rubbers for an hour or two before cutting them to length, as they may stretch and then shrink during insertion.
- ☑ Do not cut the rubbers until they are all inserted.

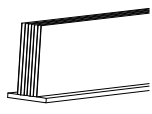
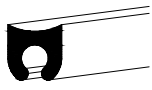
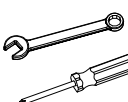
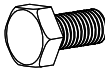
Part	#	mm	Qty	Part	#	mm	Qty
	L12	640	1		L01A	2073	1
					L01B	2073	1
	L13A	640	1		L01C	1474	1
					L01D	1474	1
	L13B	640	2		L04	592	1
	L38	640	1		L05	1300	1
	L15	602	2		L06A	1547	4
					L06B	620	1
					L06C	640	1
					L06D	1558	2
	L16	602	2		L07A	1869	1
					L07B	3706	1
					L07C	626	1
					L07D	646	1
	L17	700	4		L08A	2358	1
					L08B	2358	1
					L08C	1780	1
					L08D	1780	1
	L18	638	2		L08E	1474	5
					L08F	2046	5
					L08G	2069	1
					L08H	2069	1
	L21	259	1		L09	3708	1
	L22	1865	1		L10	3708	1
	L23	2042	5				
	L37	1842	1		L11A	1816	1
					L11B	1816	1

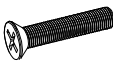
Part	#	mm	Qty	Part	#	mm	Qty
	M01	M6	113		W2		2
	M02	M5	2				
	Z01	Ø4*16	24		W5		2
	Z02	Ø4*6	4				
	H3		2		W07A	655	1
					W07B	645	1
					W07C	3758	1
					W07D	1900	1
	J04		1		W08	350	6
					W09		13
	J04L		1		W11		20
	J04R		1		W13	Ø12*28	3
	J11		2		W14		210
	J13		4		W15		6
	J15	Ø6.5*20	4		W21	Ø12*Ø6*1.5	2
					W16		1
					W17		1
	J18	1.82M	2		W46		2
	J19	78M	1				
	T01		1		S01	M6*10	90
	T02		1		S02	M6*16	24
					S03	M6*40	3
					S04	M6*14	5
					S05	M5*25	2

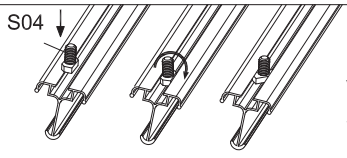

**Important tip:**  
 You don't need to disassemble everything if you forgot to put in the S01 screws, you can replace them with the S04 screws!



S07 M6\*60 12



## Assembling the base

It is essential that the base of the greenhouse is perfectly square so that the diagonal measurements are identical. The greenhouse must also be uniformly level on the front and back sides, the plumbness must be perfect.

Anchoring the greenhouse to the ground is essential. We recommend using masonry anchors if you have a slab, in which case you would cut the anchor legs.

Alternatively, the anchors can be concreted into the ground (footing min 300 mm diameter and 400 mm deep). It is often best to do this at the end, if time permits. Always fix the structure temporarily during construction.

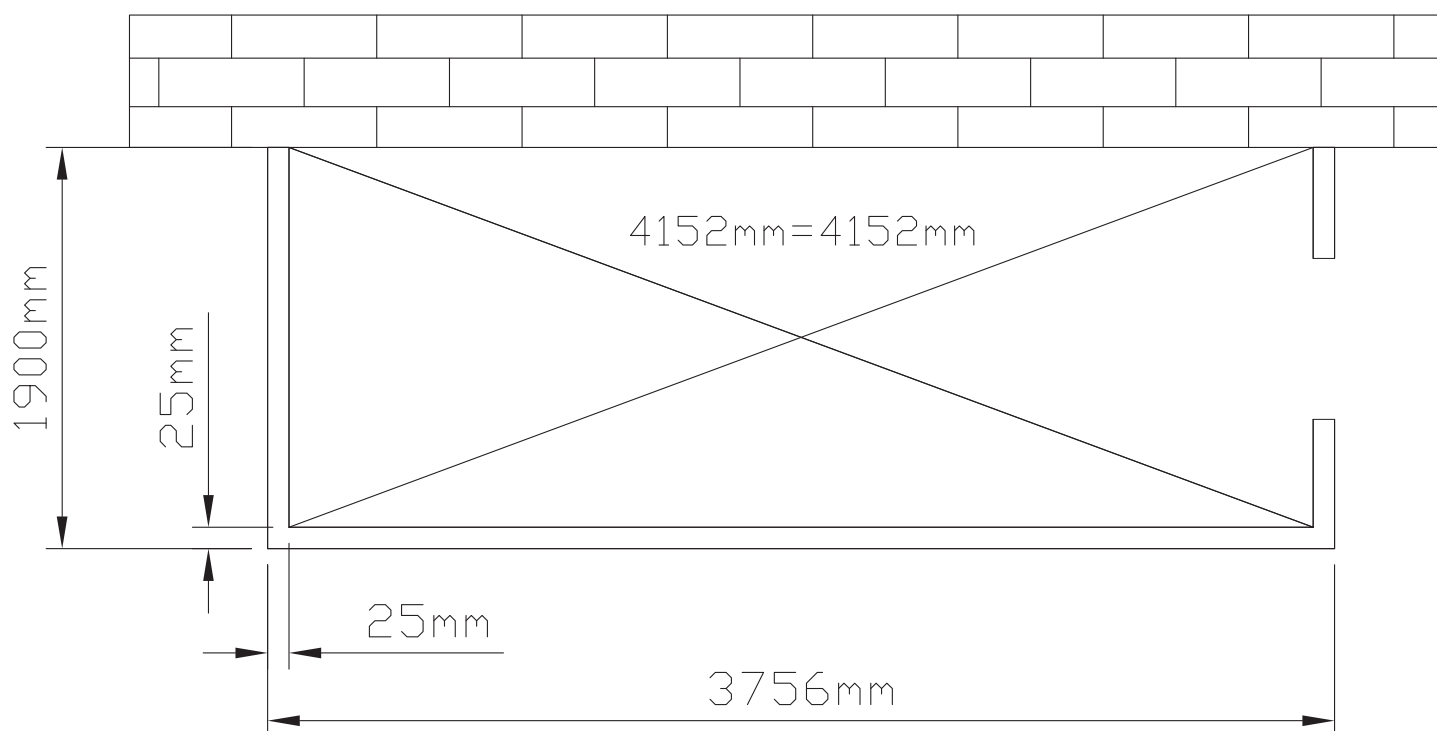
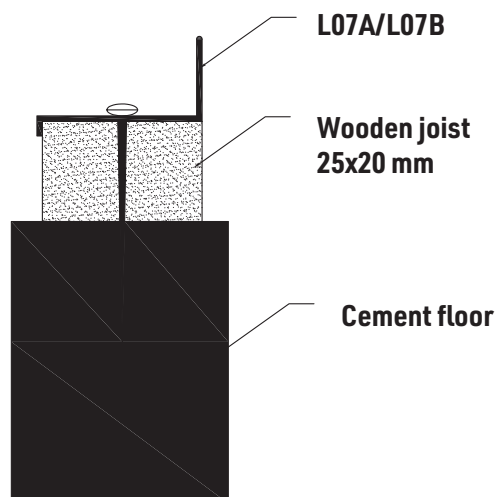

# Assembling the base

**Note:** Please remove the protective film on the surface of parts W08 and W07 A (B/C/D) before assembling the base

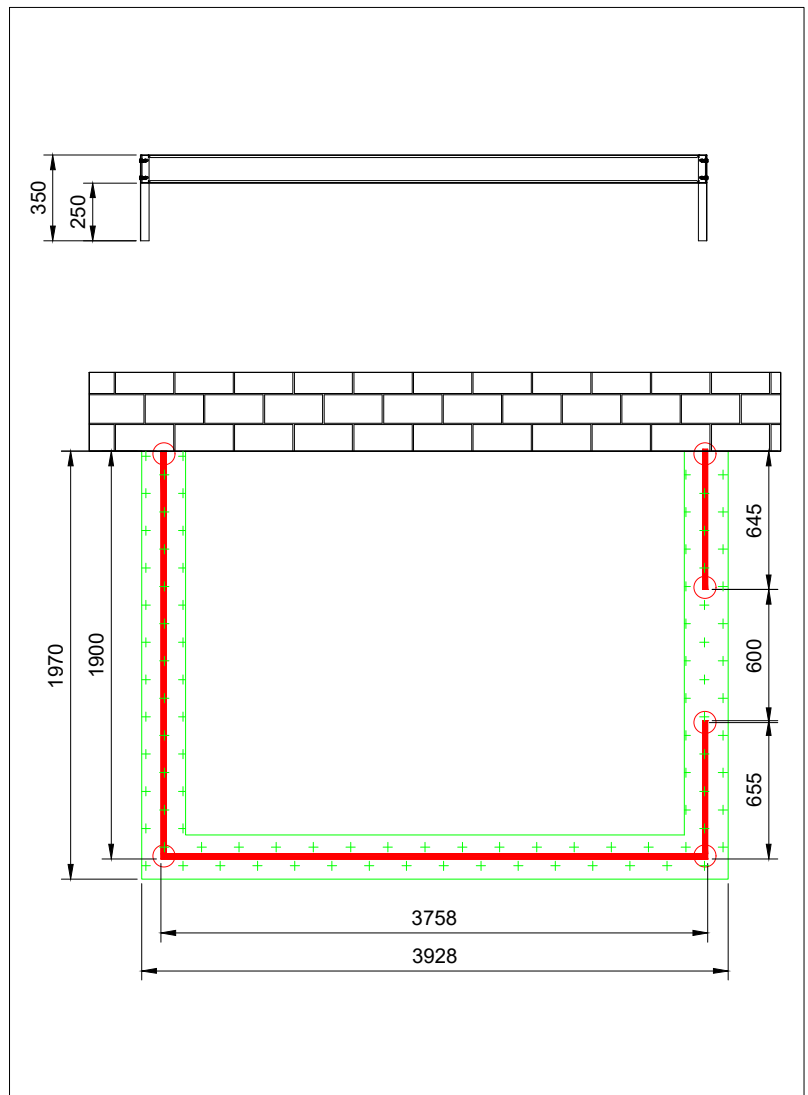
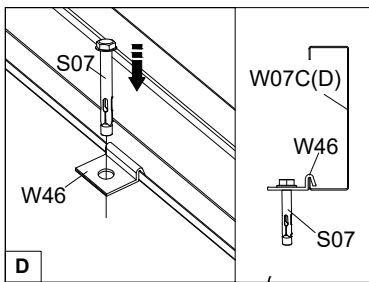
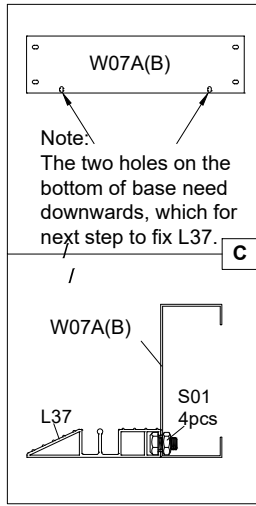
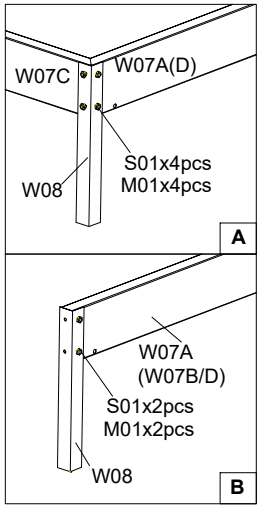
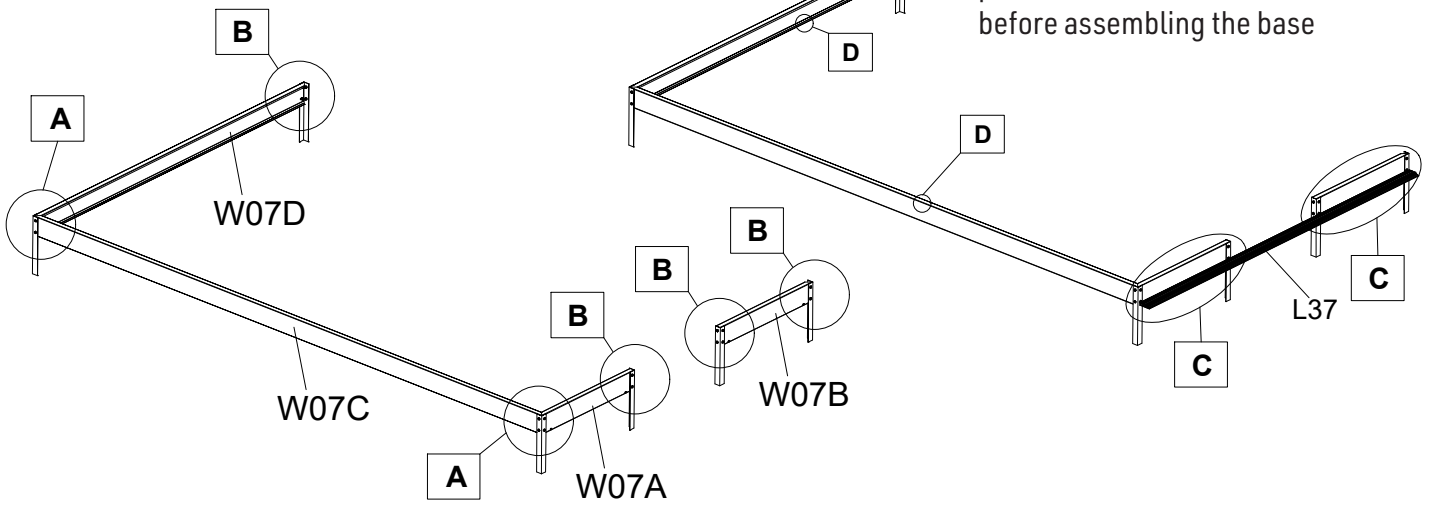

# Door assembly

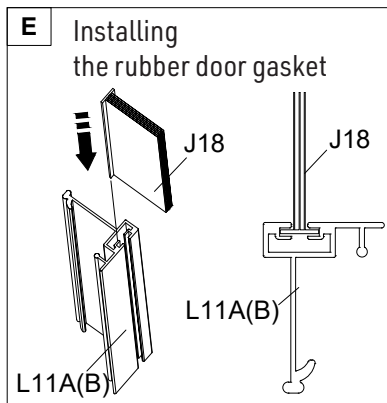
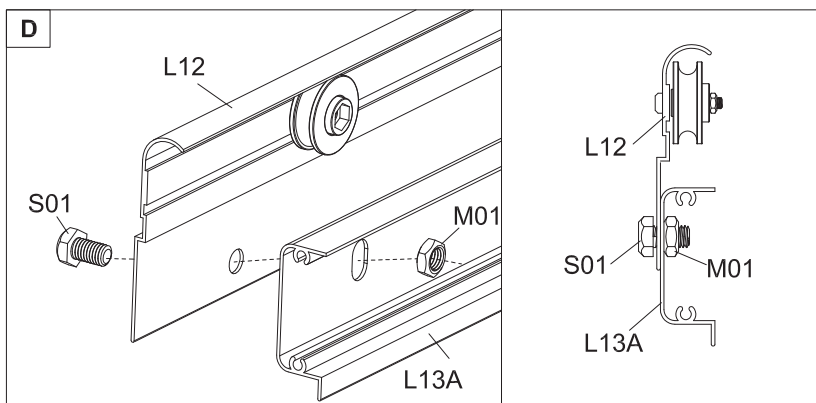
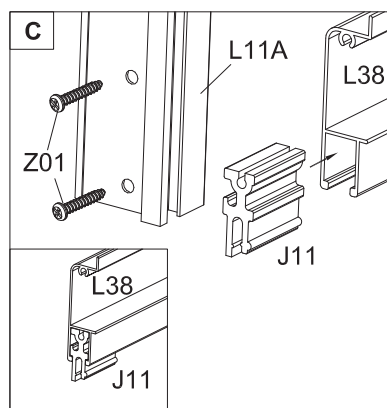
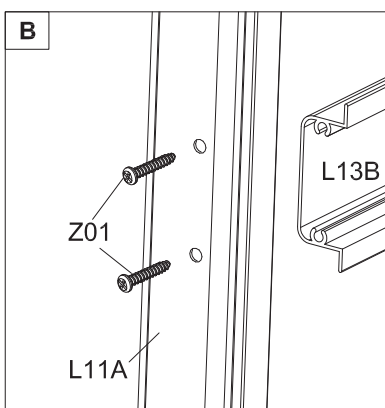
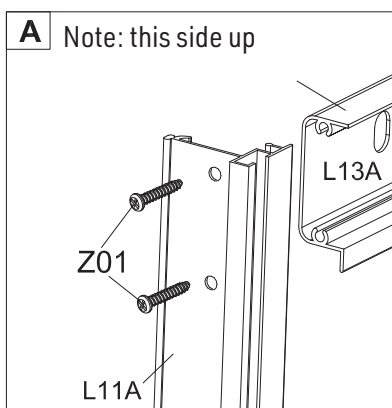
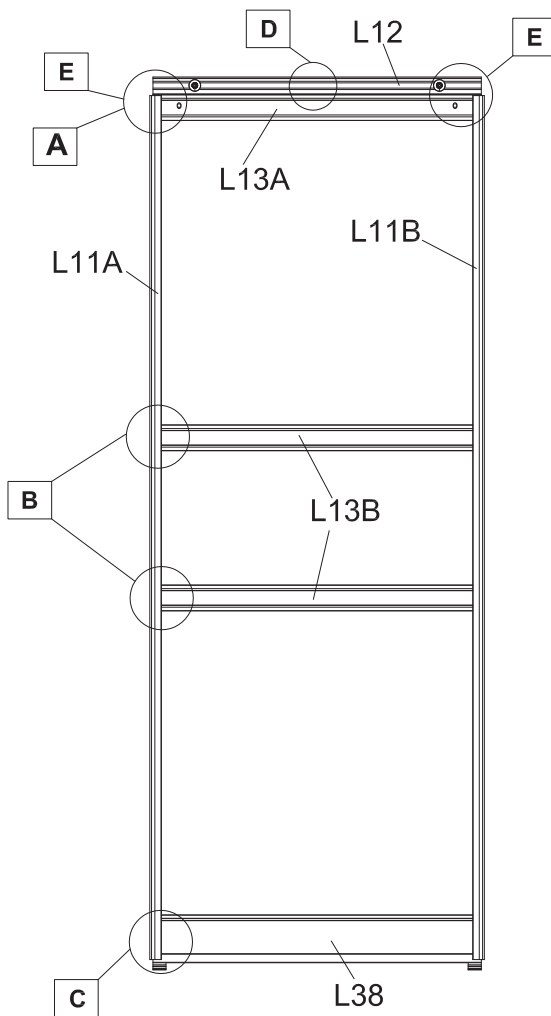

# Window assembly

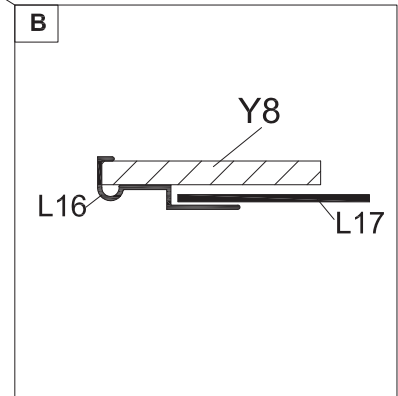
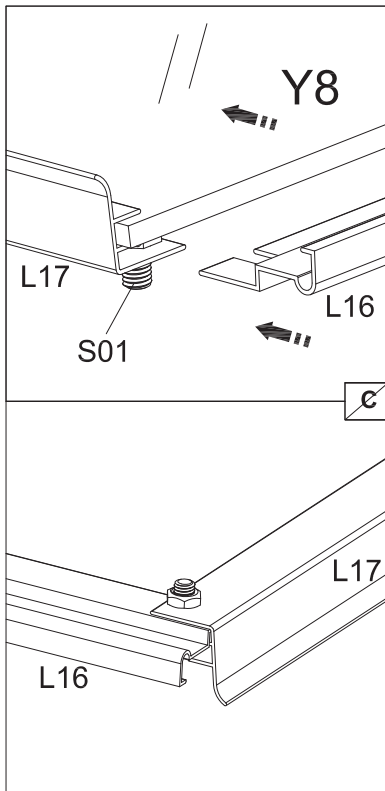
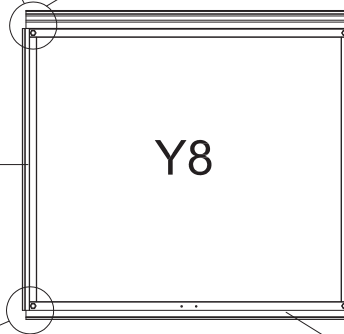
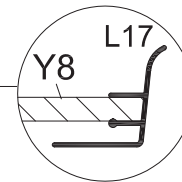
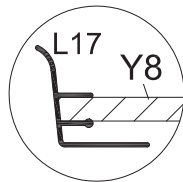
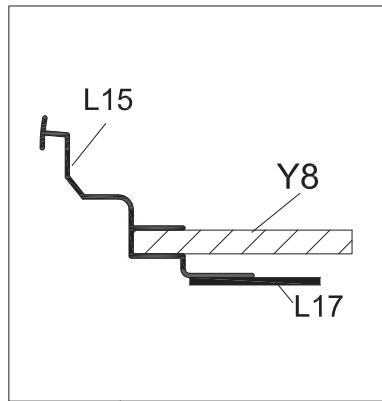
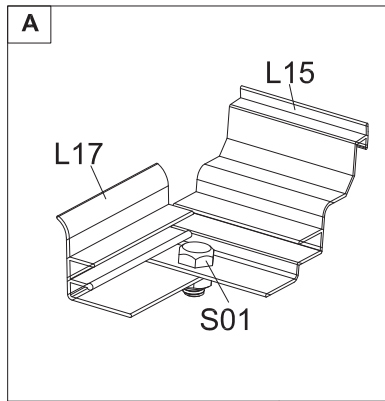

# Front gable assembly

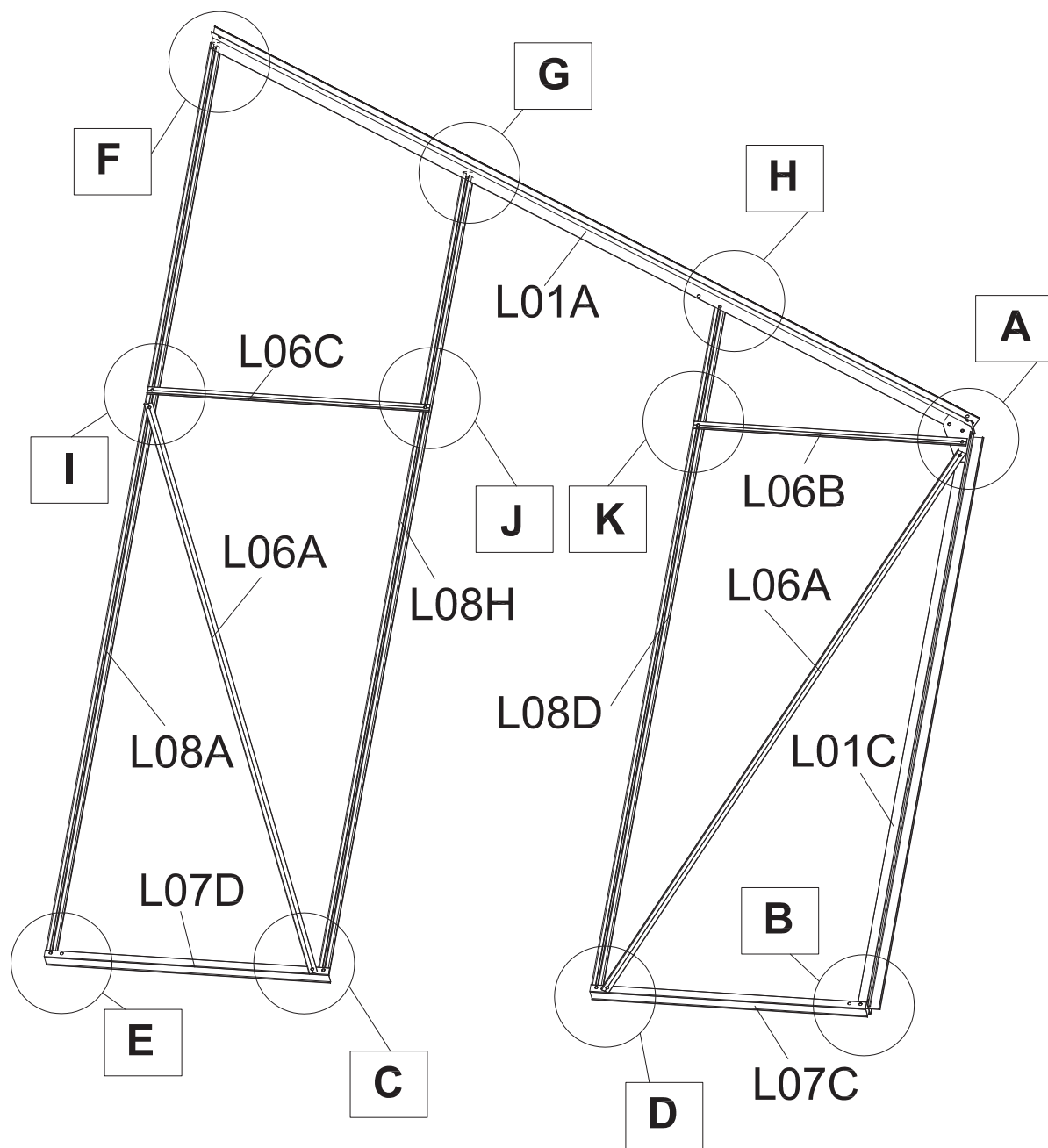

# Front gable assembly

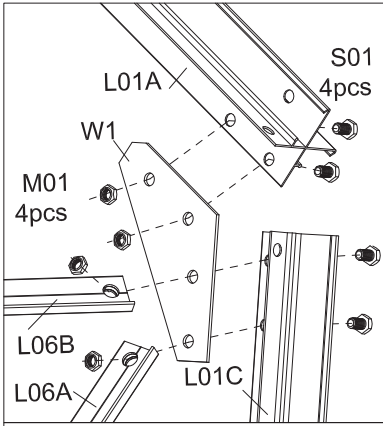

Please do not tighten the nuts before positioning part L09

**A**

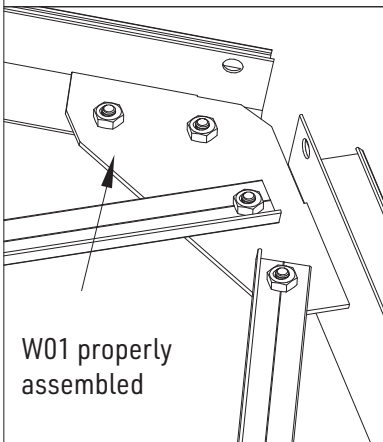

W01 properly assembled

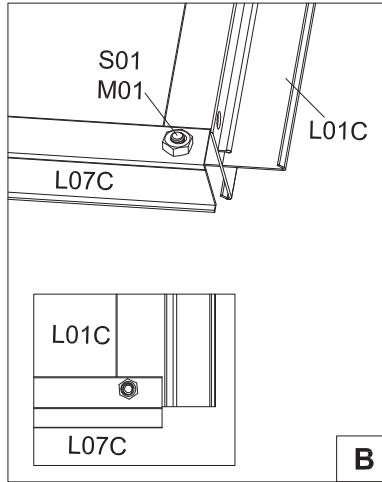

**B**

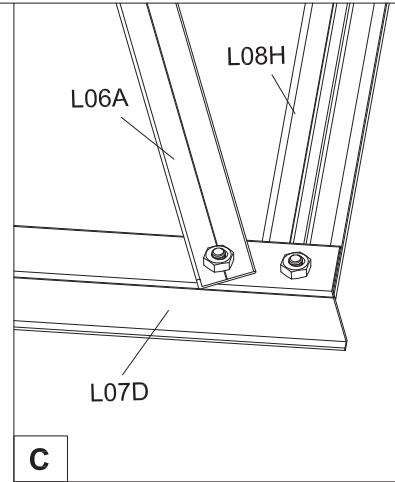

**C**

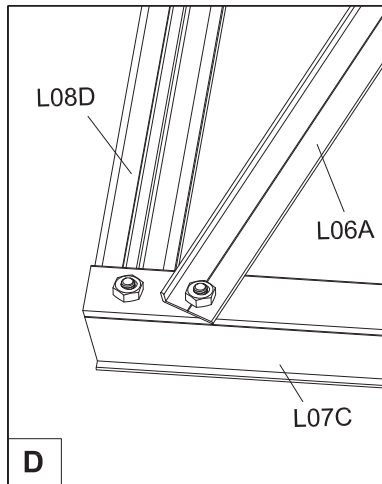

**D**

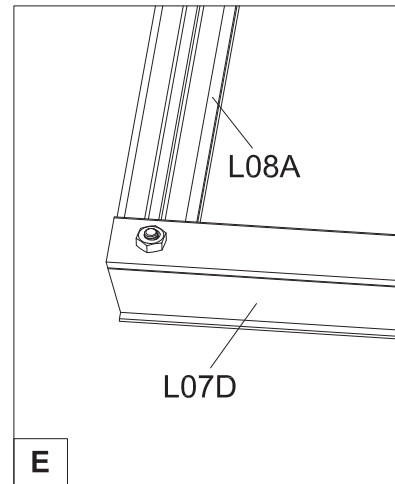

**E**

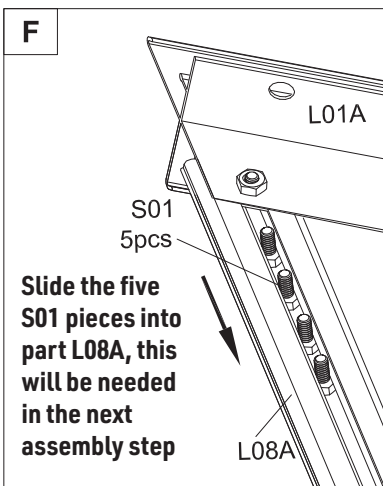

Slide the five S01 pieces into part L08A, this will be needed in the next assembly step

**F**

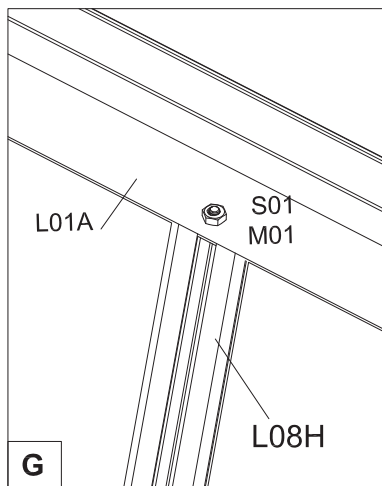

**G**

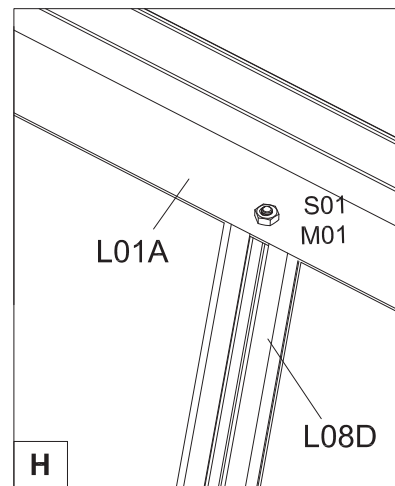

**H**

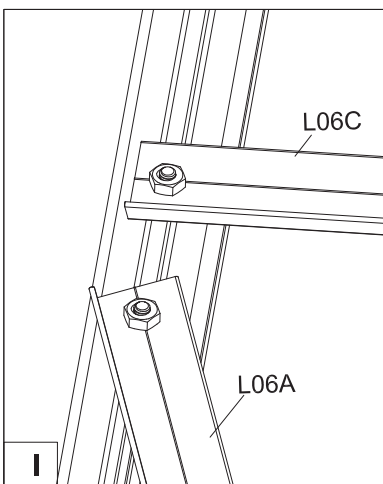

**I**

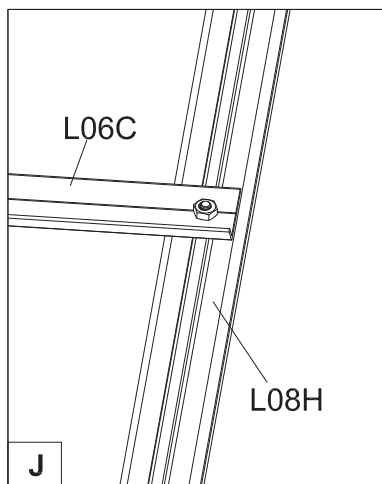

**J**

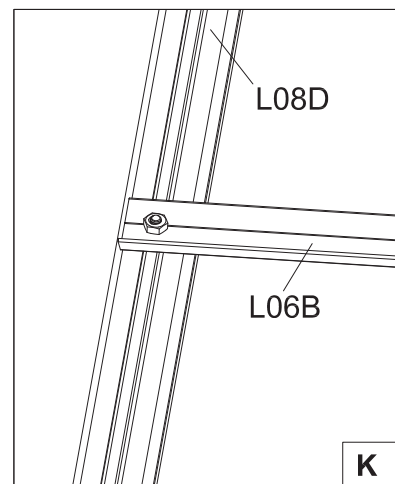

**K**



# Front gable assembly

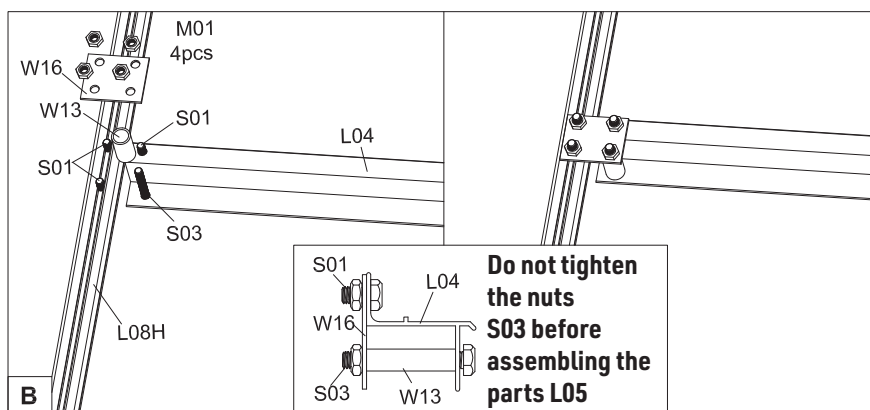
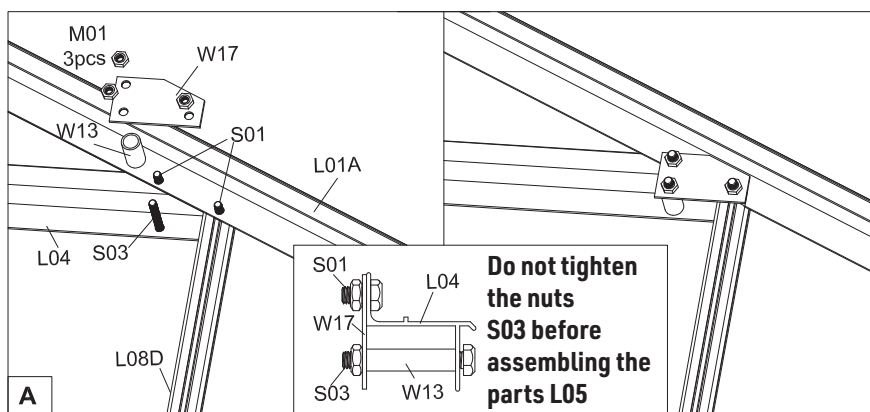
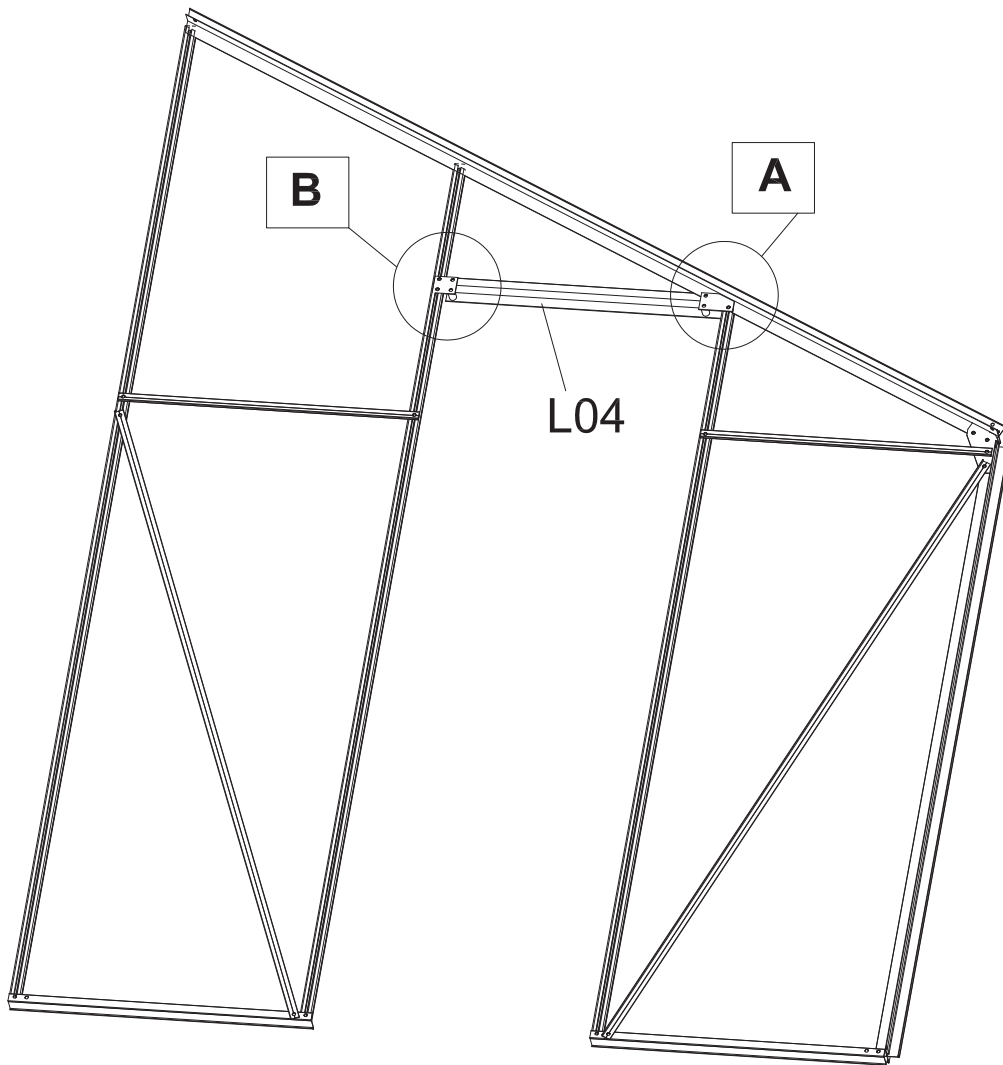

# Rear gable assembly

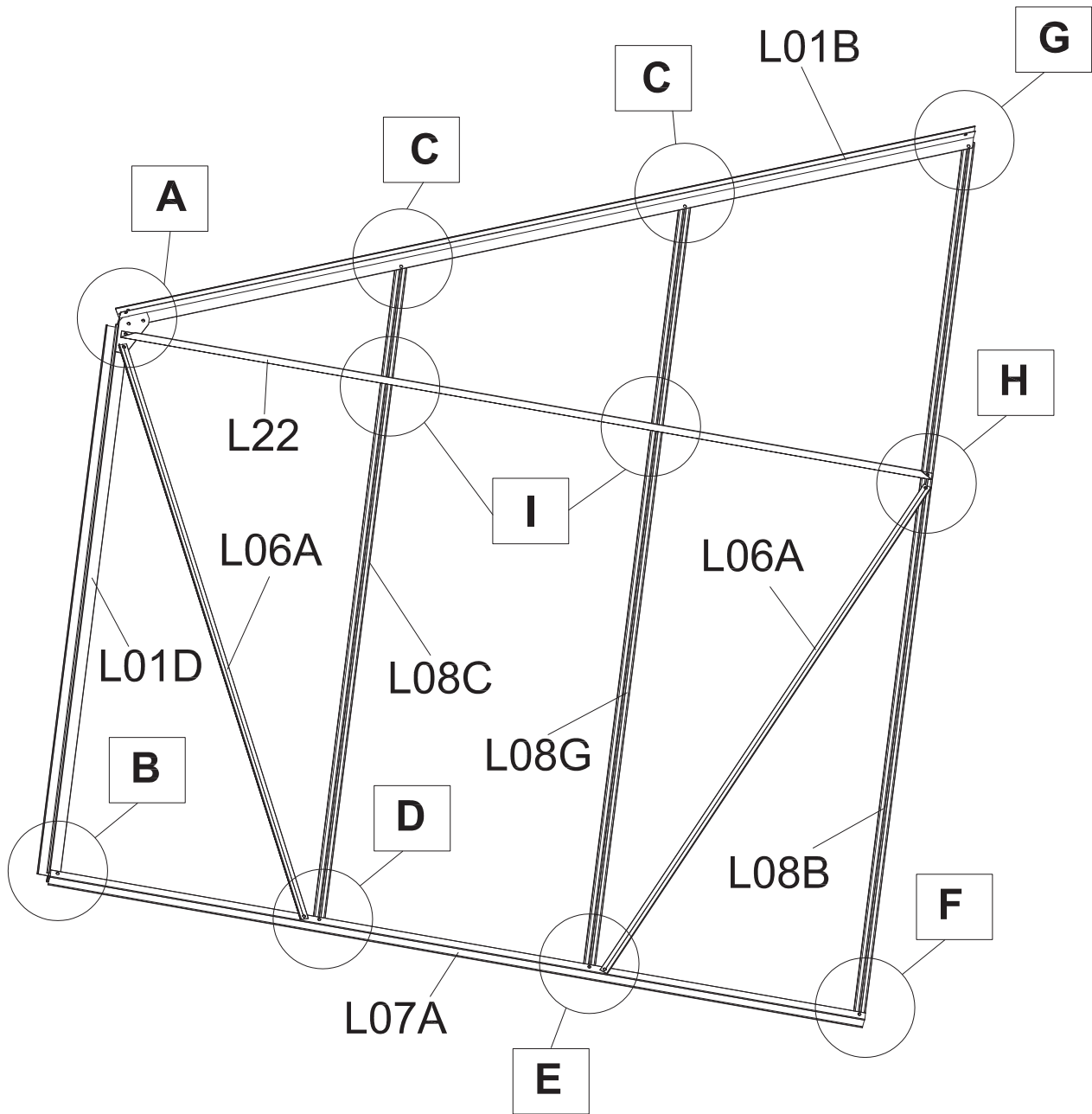

# Rear gable assembly

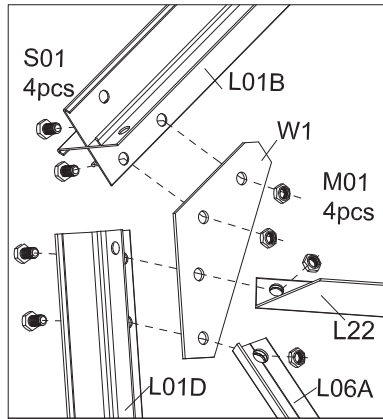

Do not tighten the nuts before installing the L09 part

**A**

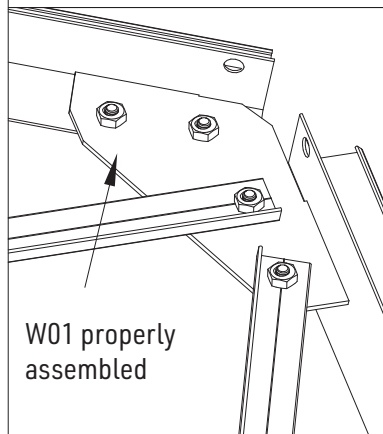

W01 properly assembled

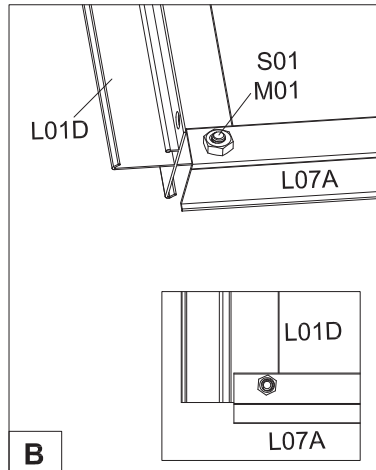

**B**

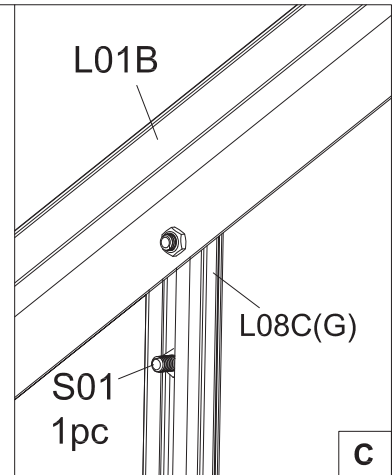

**C**

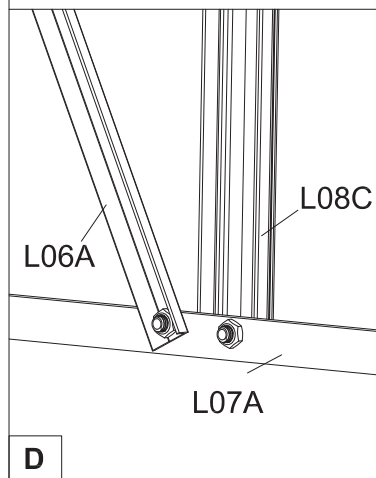

**D**

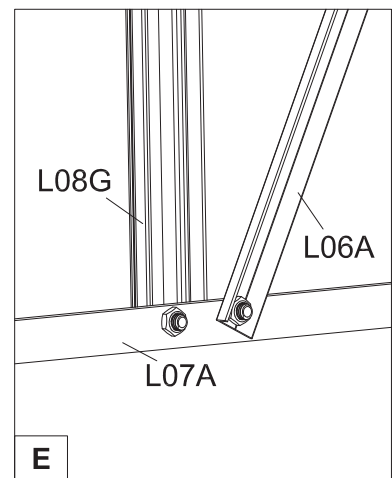

**E**

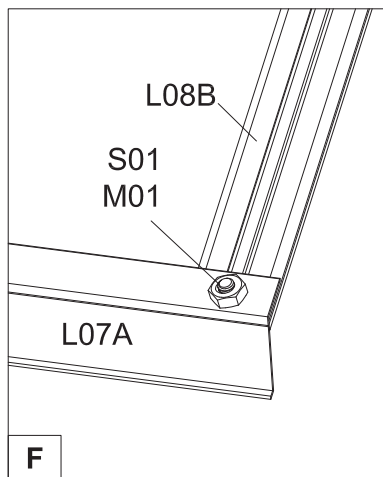

**F**

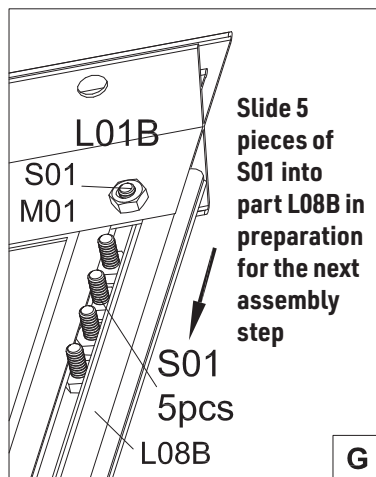

**G**

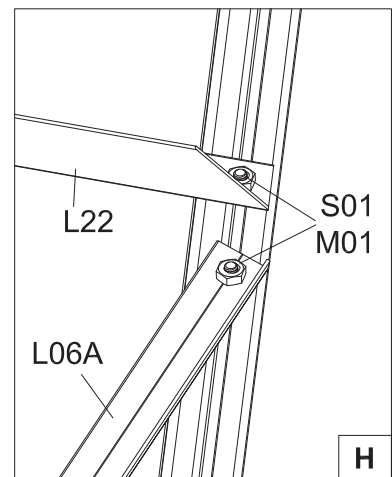

**H**

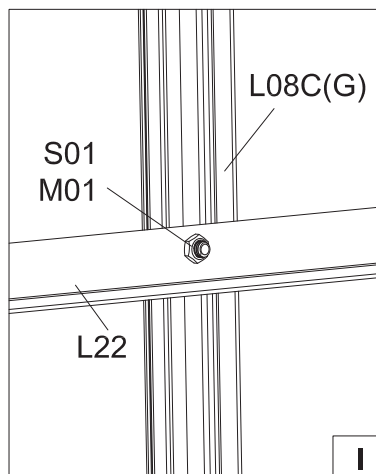

**I**



# Sidewall assembly

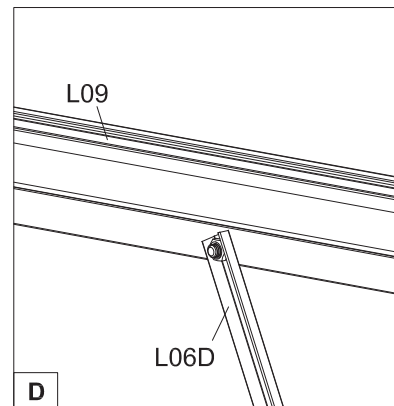
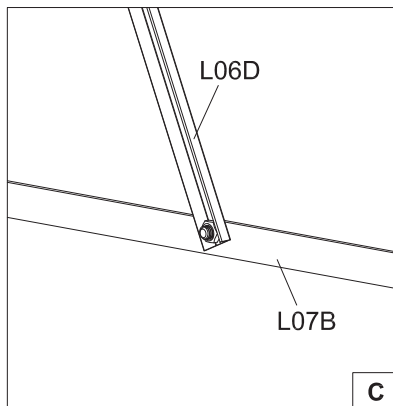
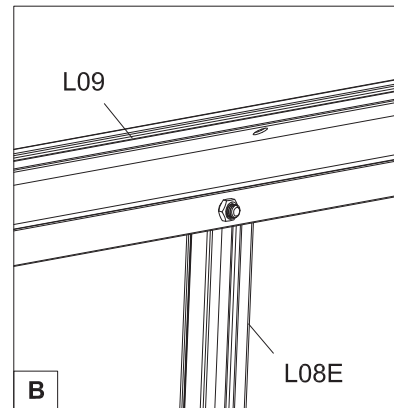
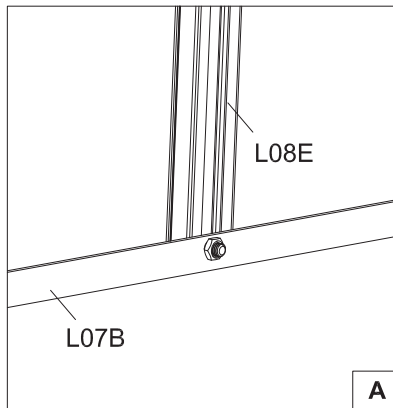
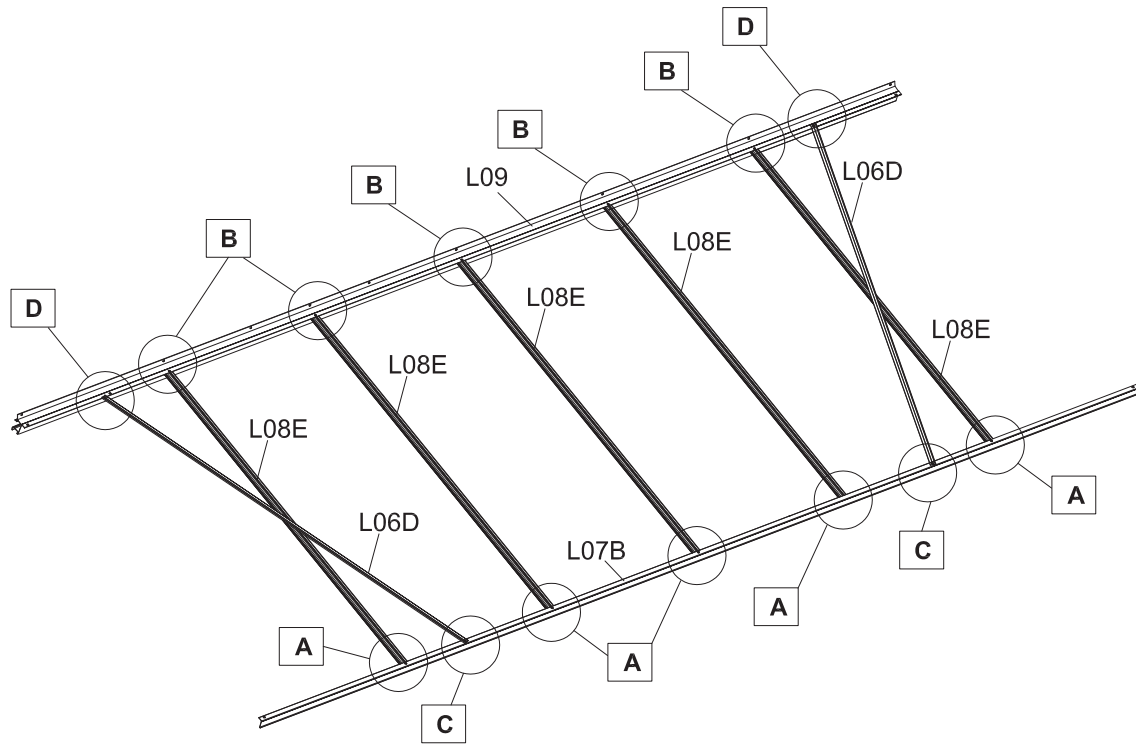

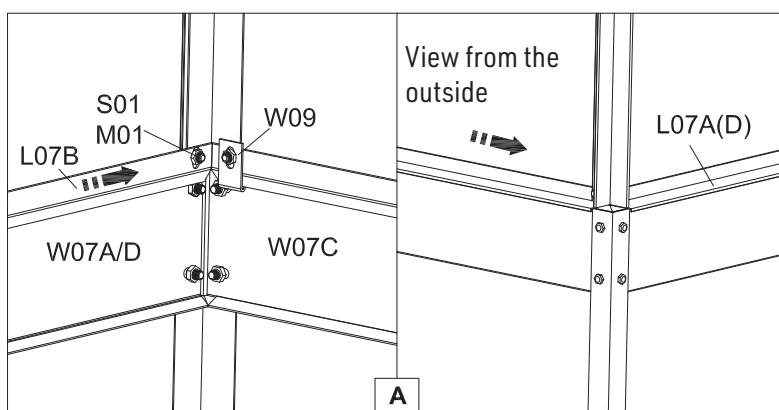
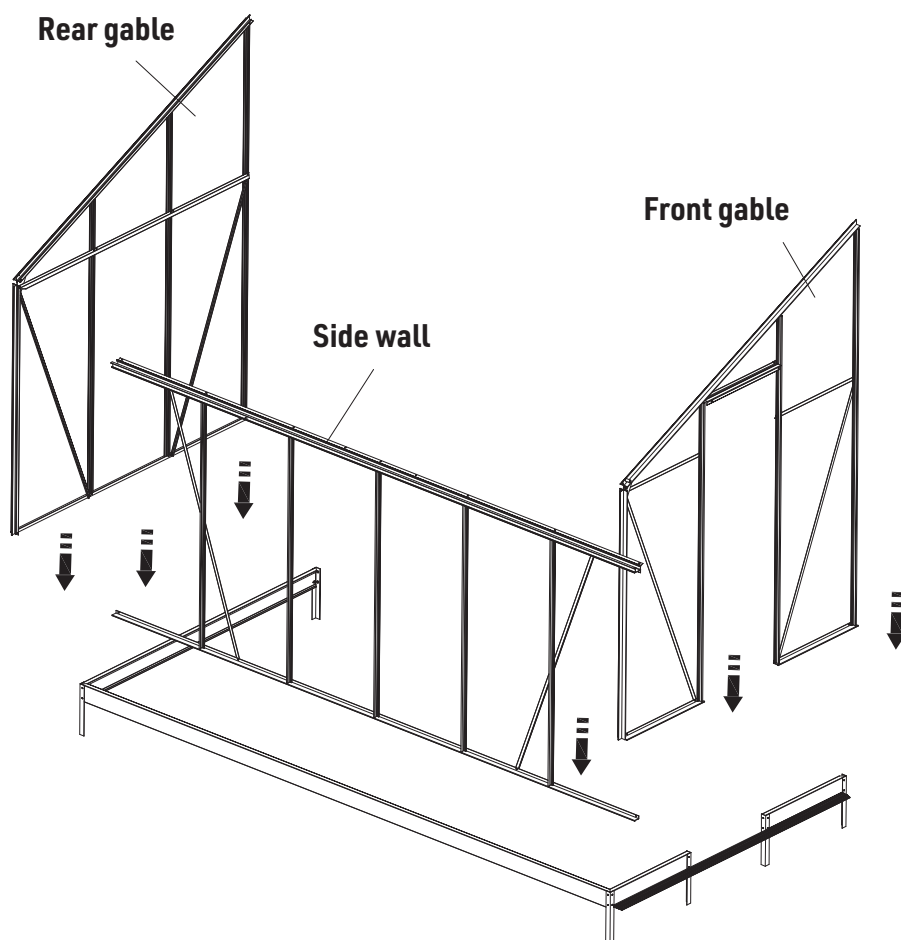

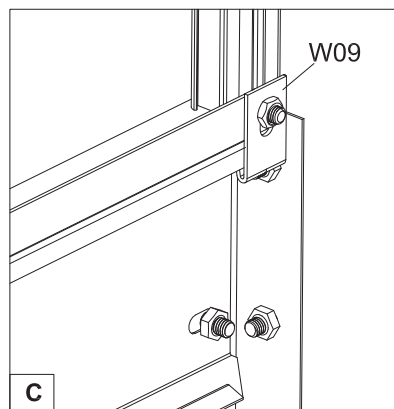
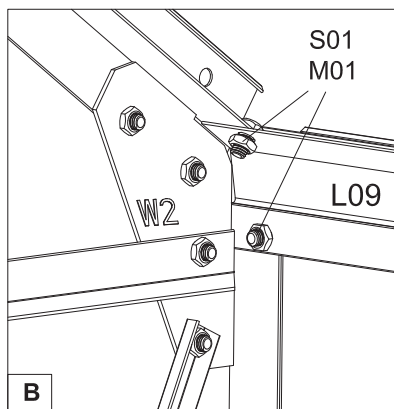
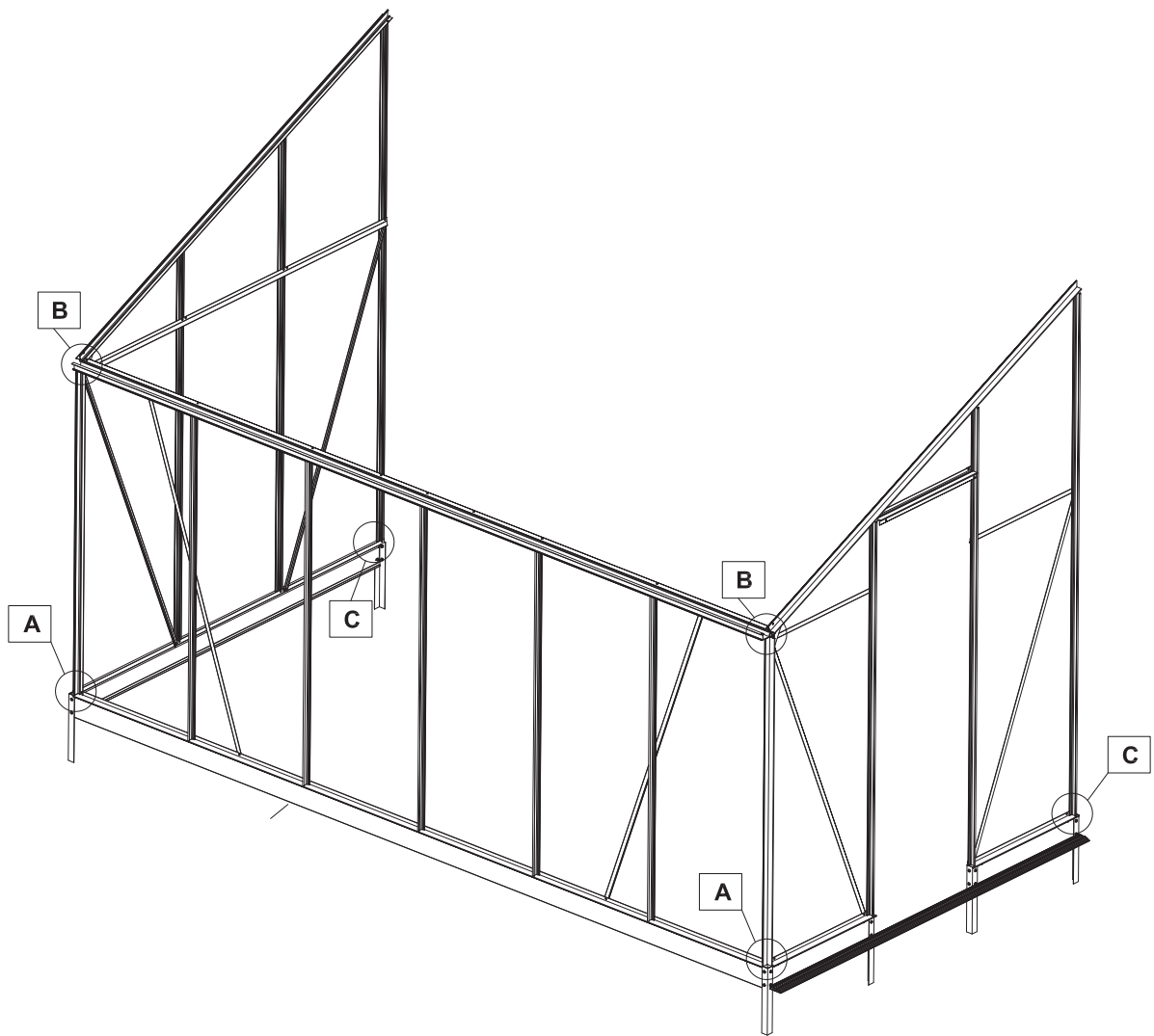

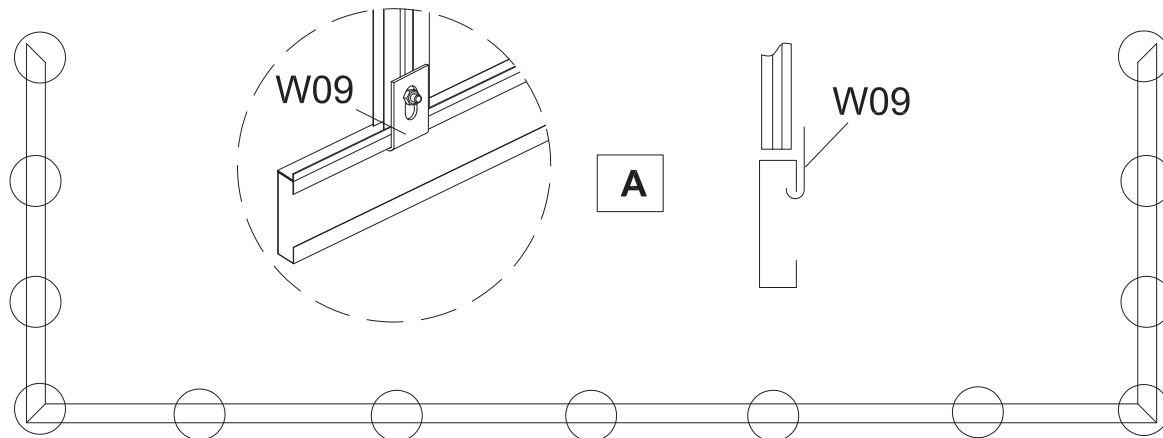
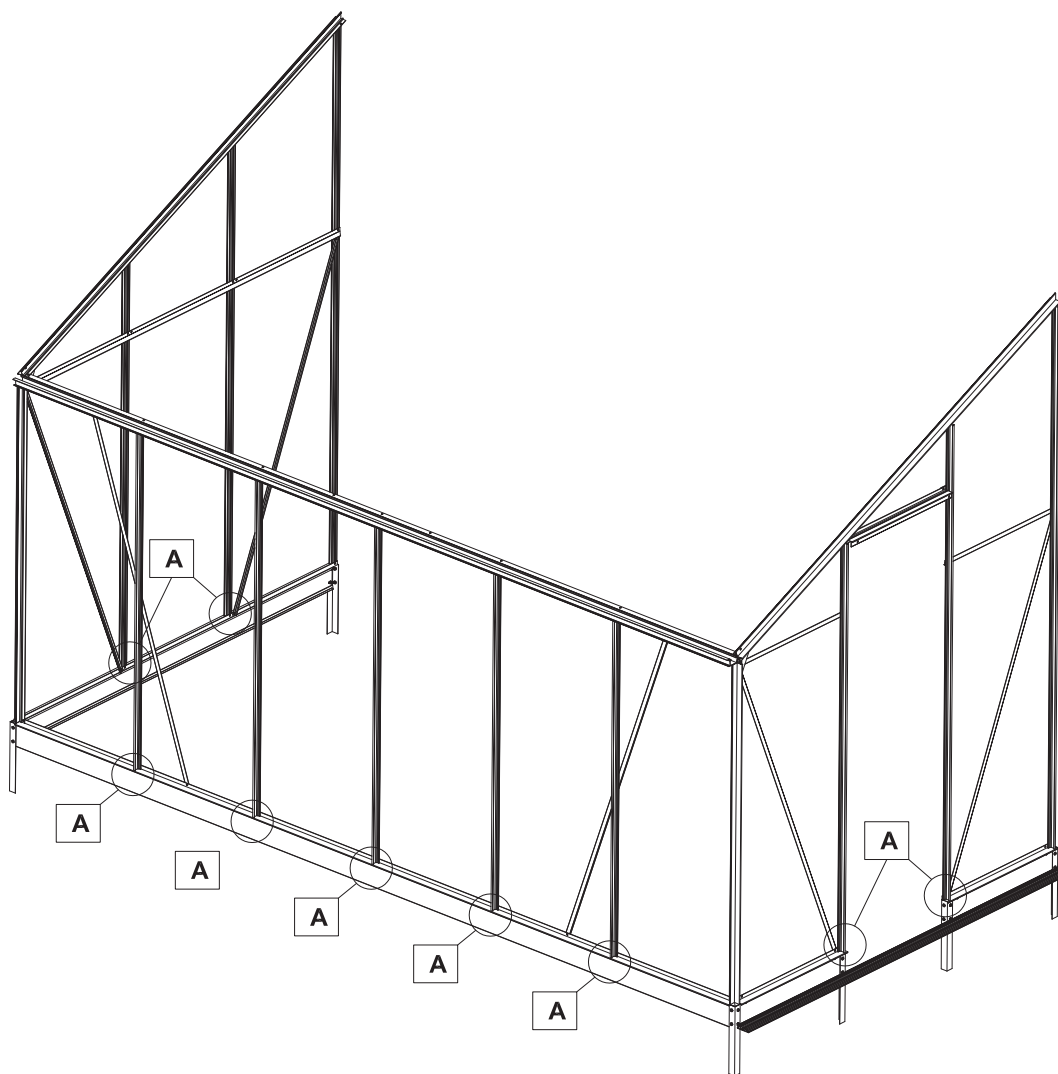

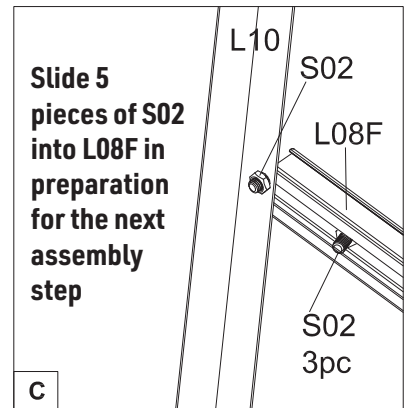
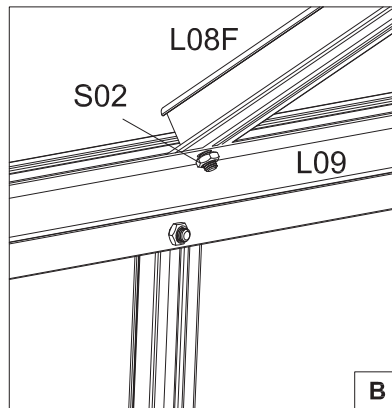
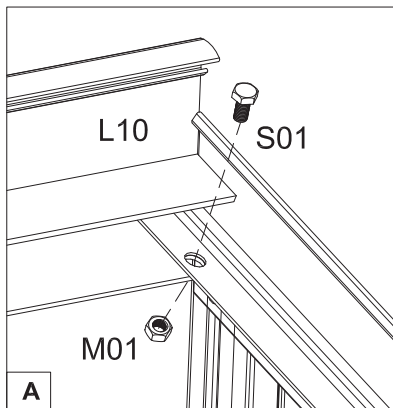
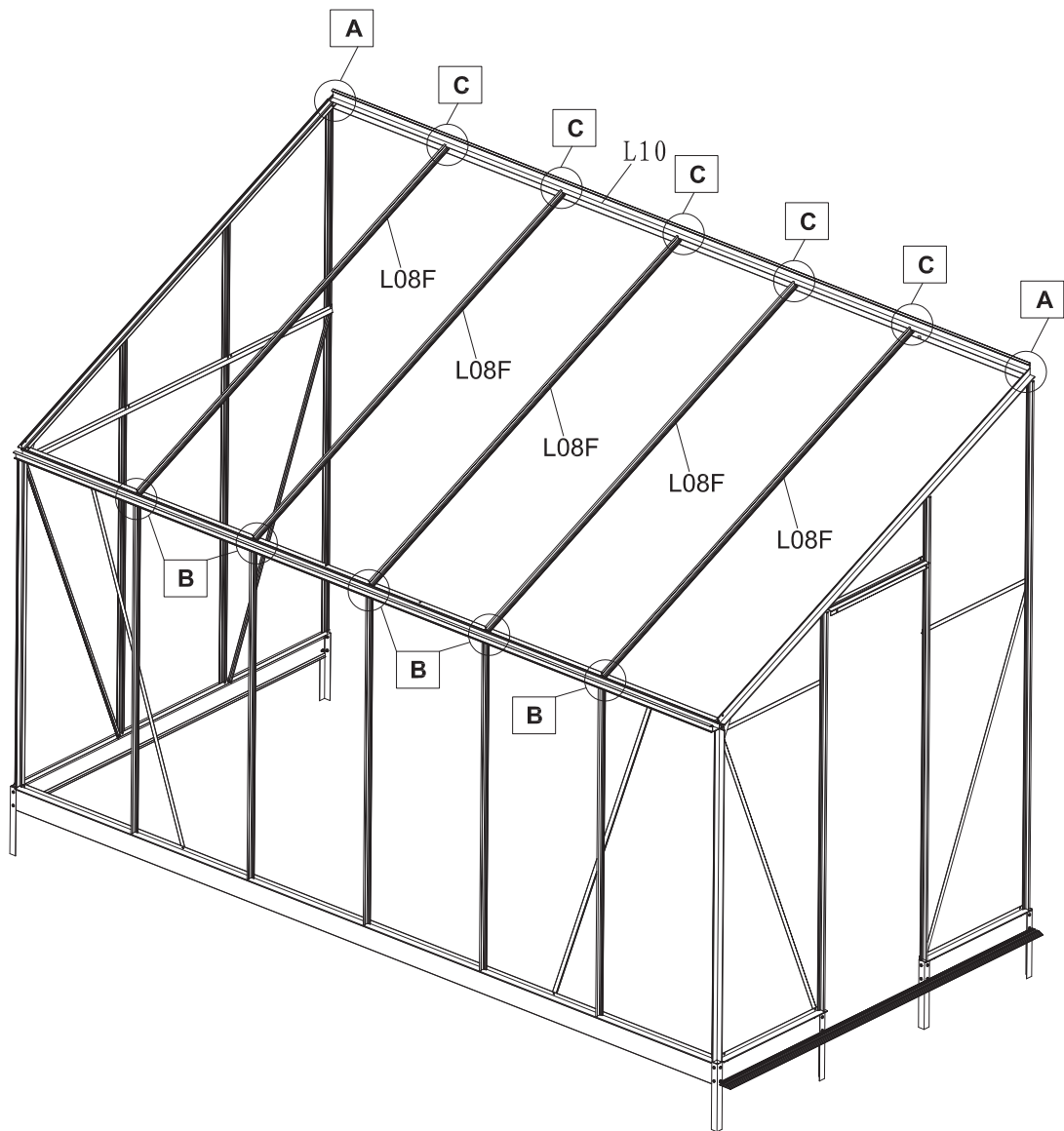

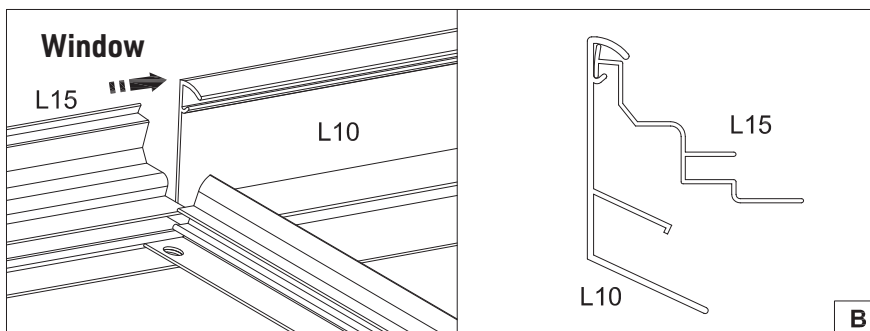
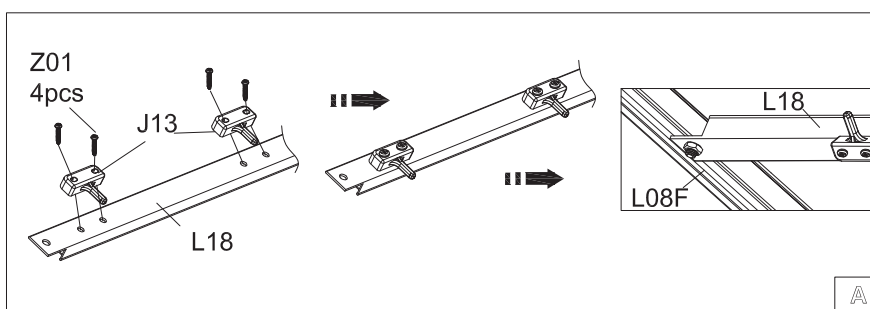
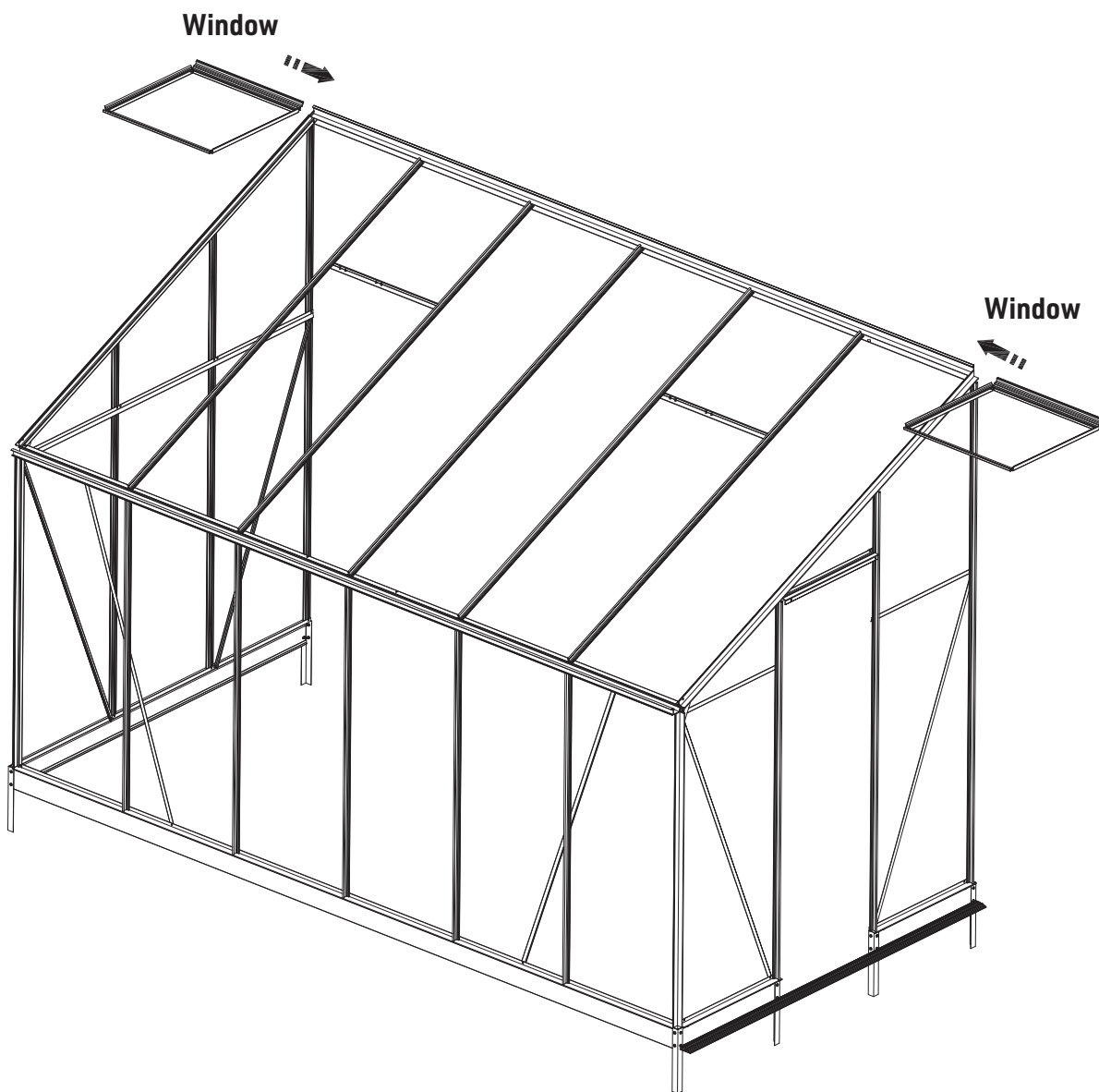

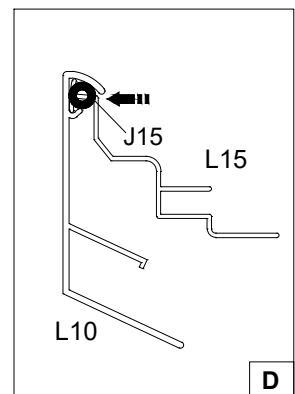
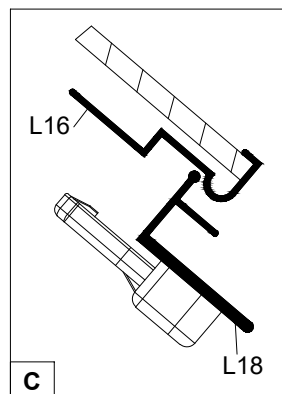
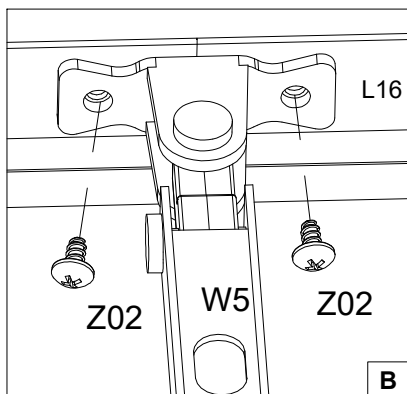
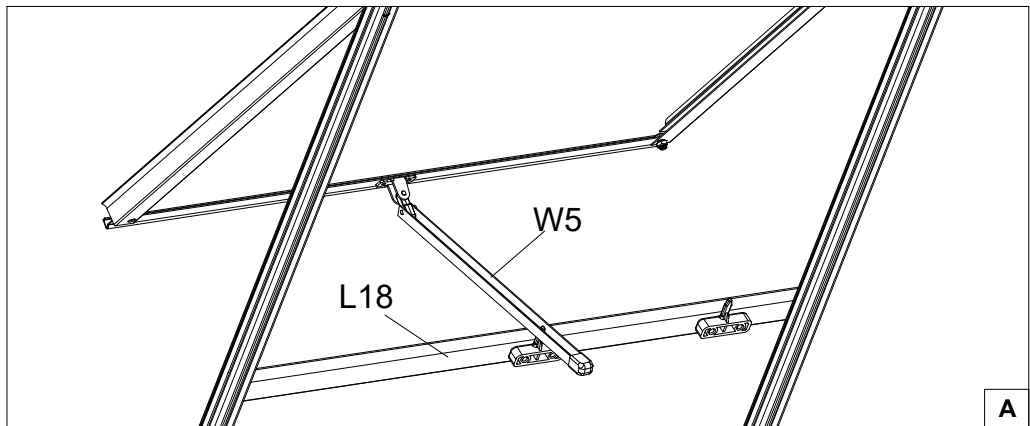
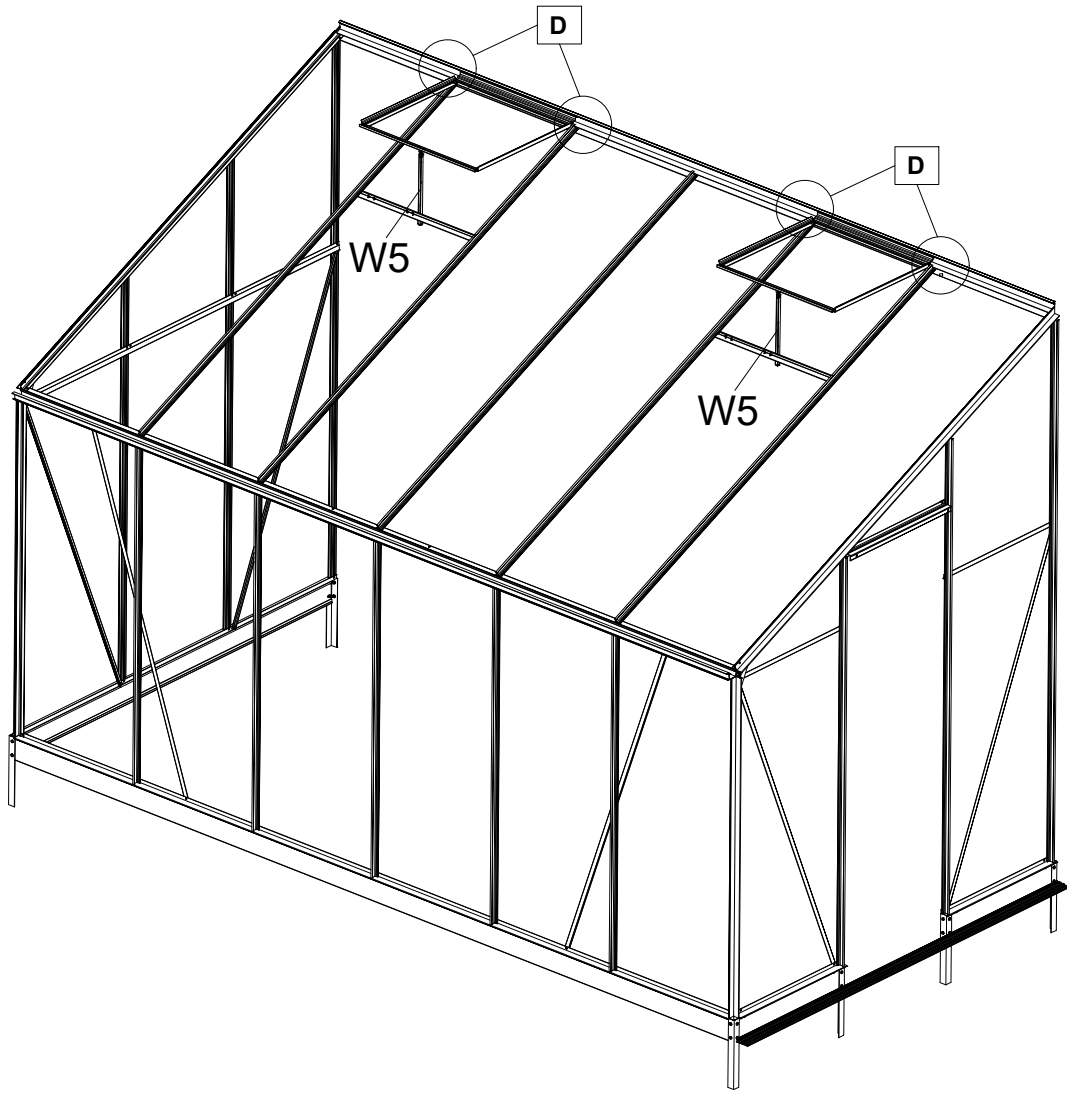

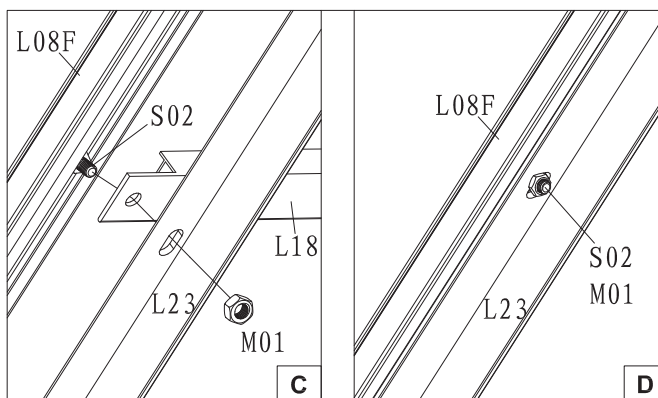
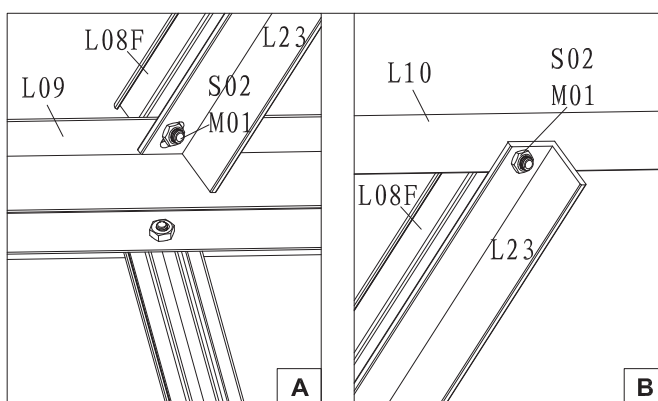
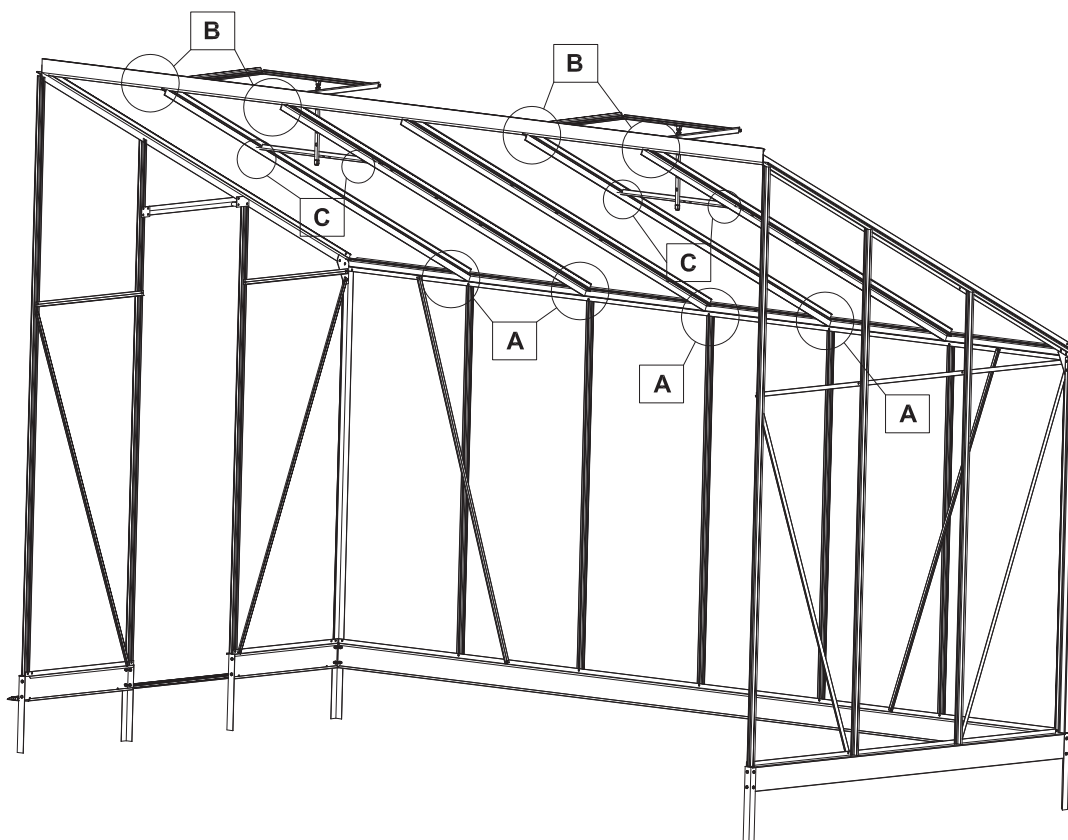

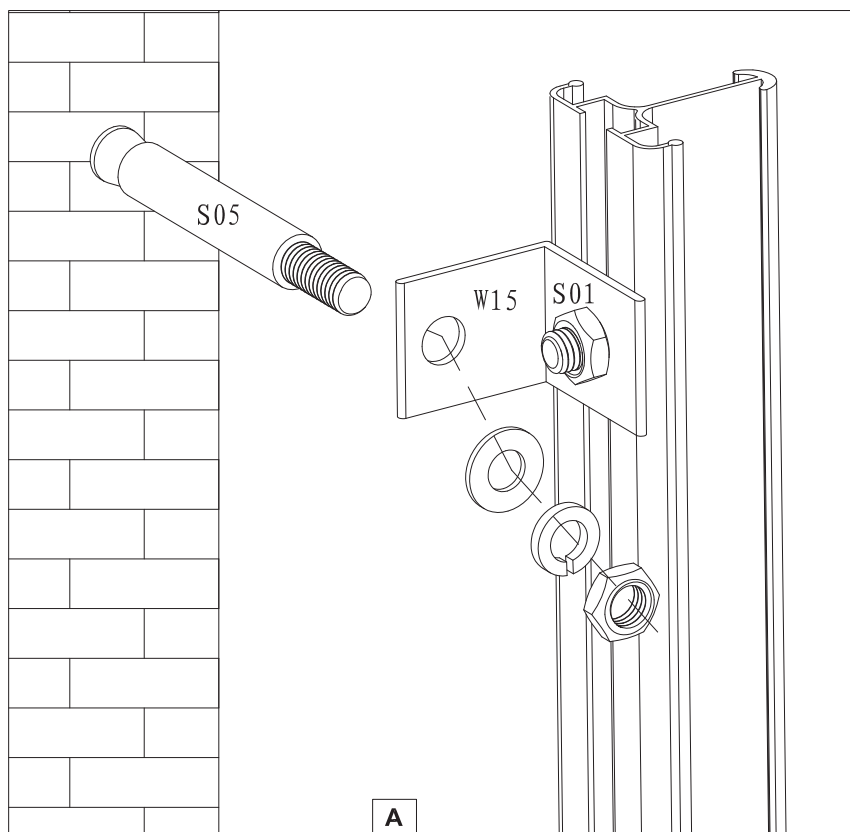
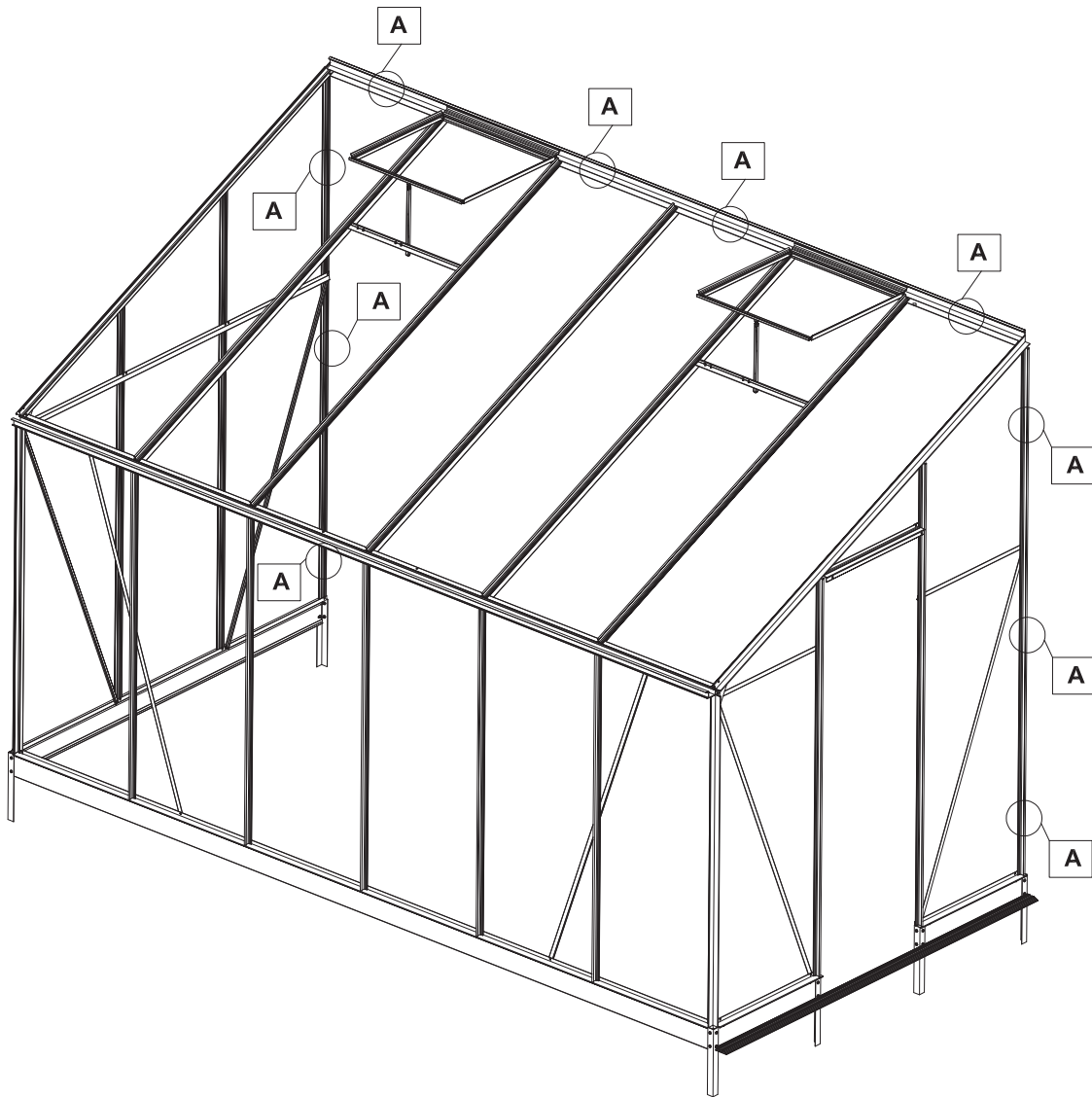

Installation of the J19 rubber gasket

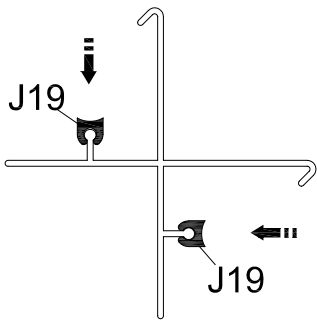

L01

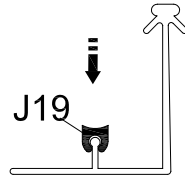

L03

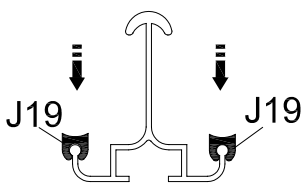

L08

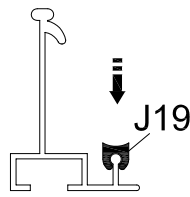

L11

Installing the glasses

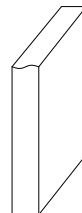
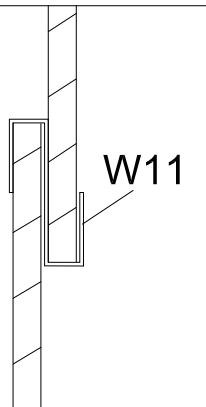
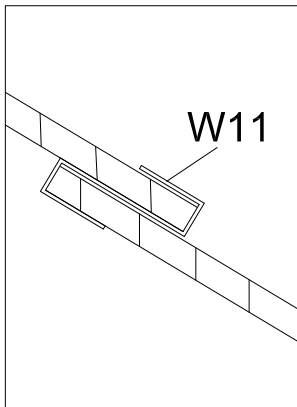
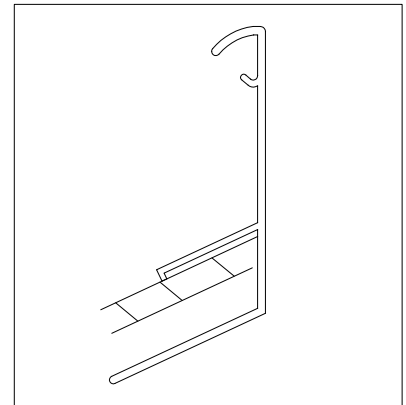
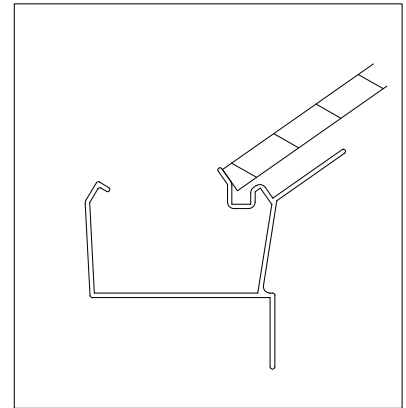

Be careful not to injure yourself when handling and adjusting the glasses

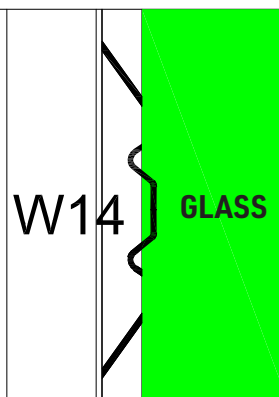
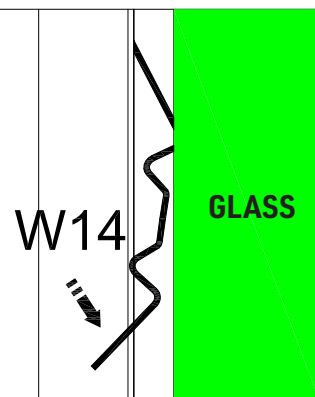
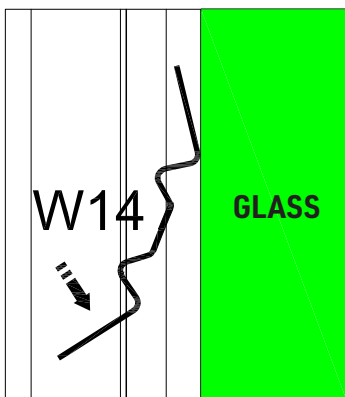
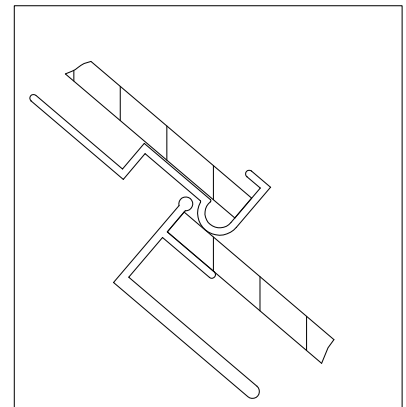

Be careful not to injure yourself when installing the W14 clips

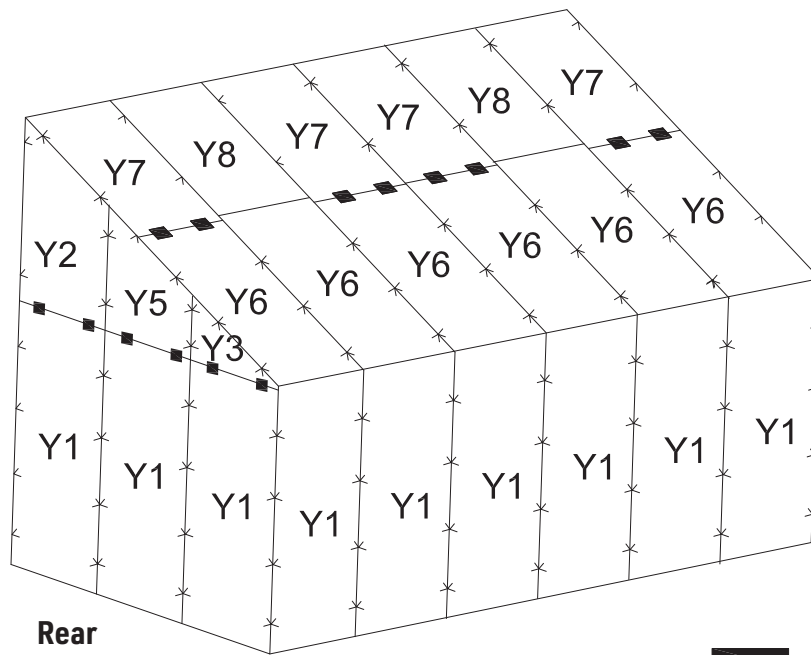
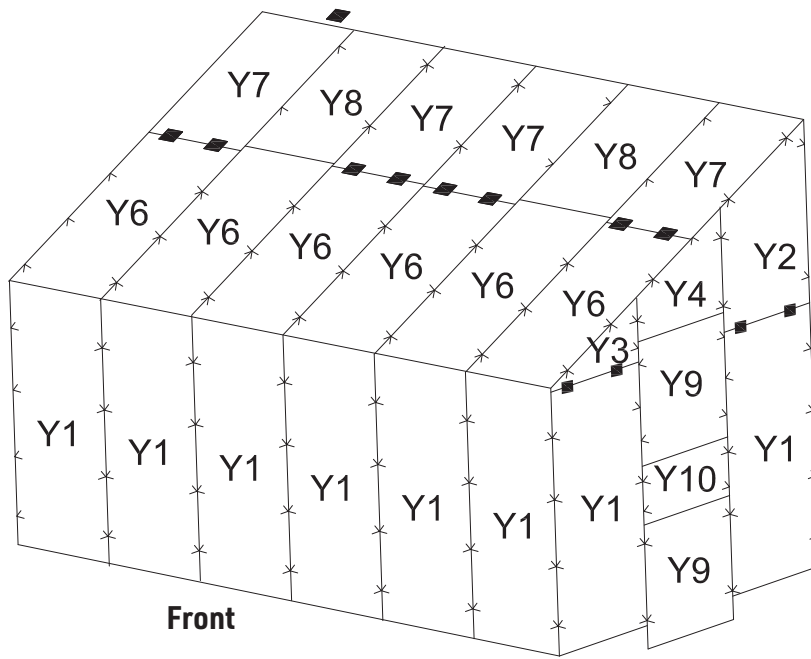

Parts	Ref	mm	Qty
	Y1	610x1472	11
	Y2	610x904x619	2
	Y3	610x326x41	2
	Y4	608x292x10	1
	Y5	610x616X330	1

Parts	Ref	mm	Qty
	Y6	610x1338	6
	Y7	610x738	4
	Y8	602x726	2
	Y9	629x609	2
	Y10	629x395	1

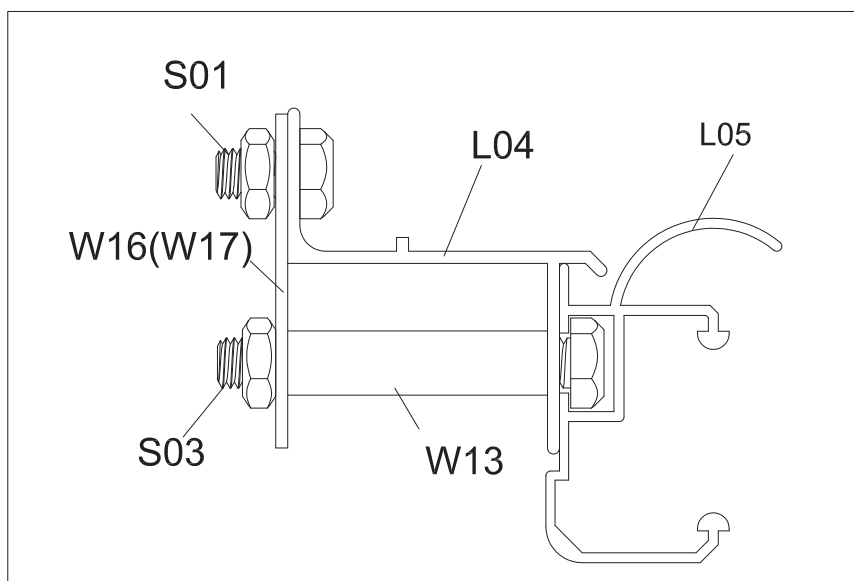
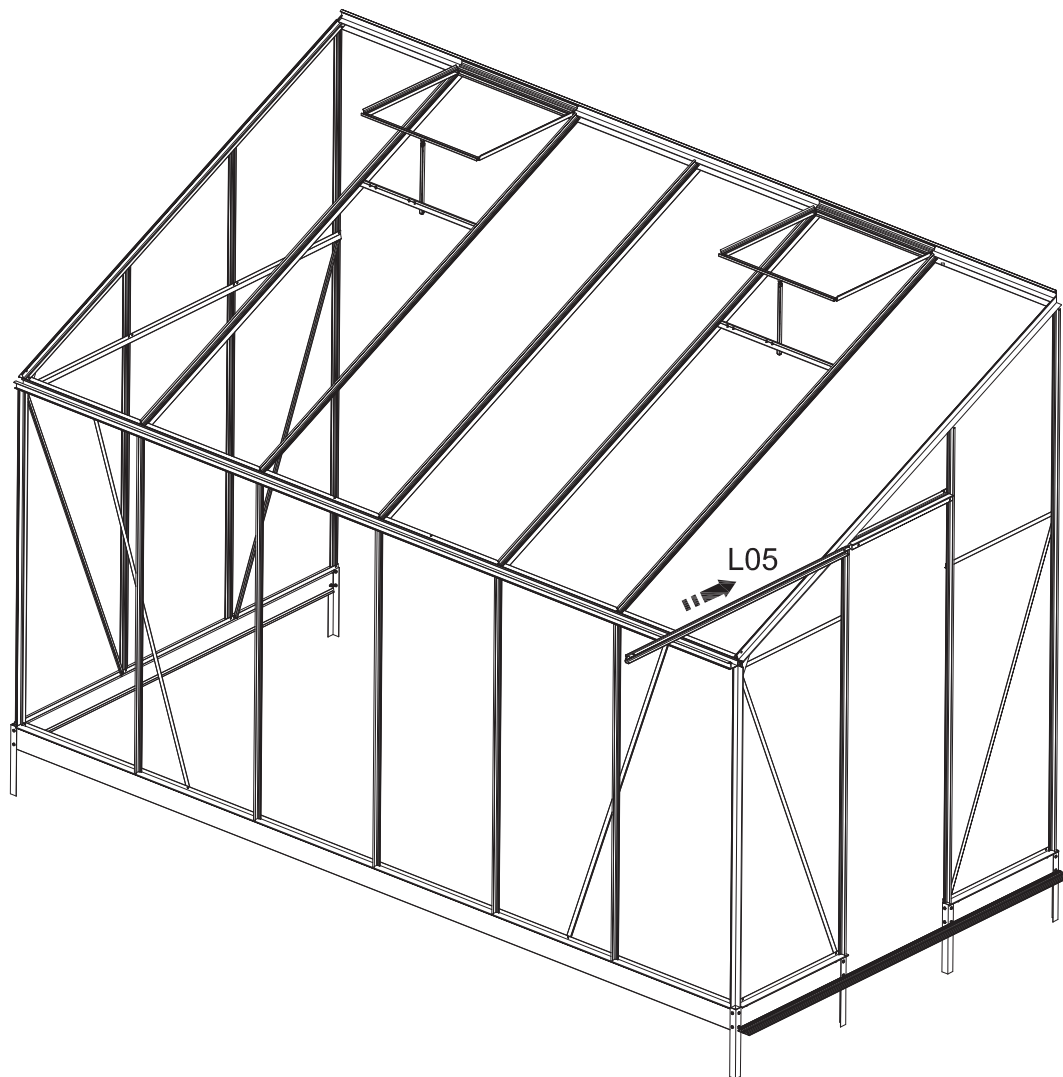

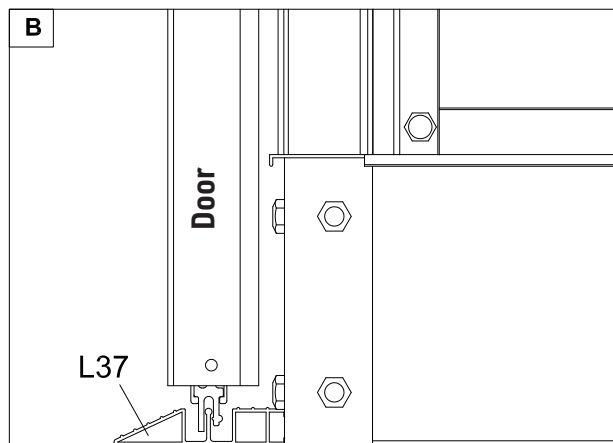
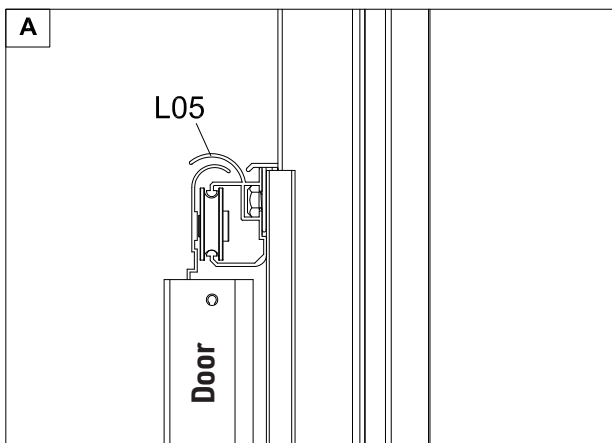
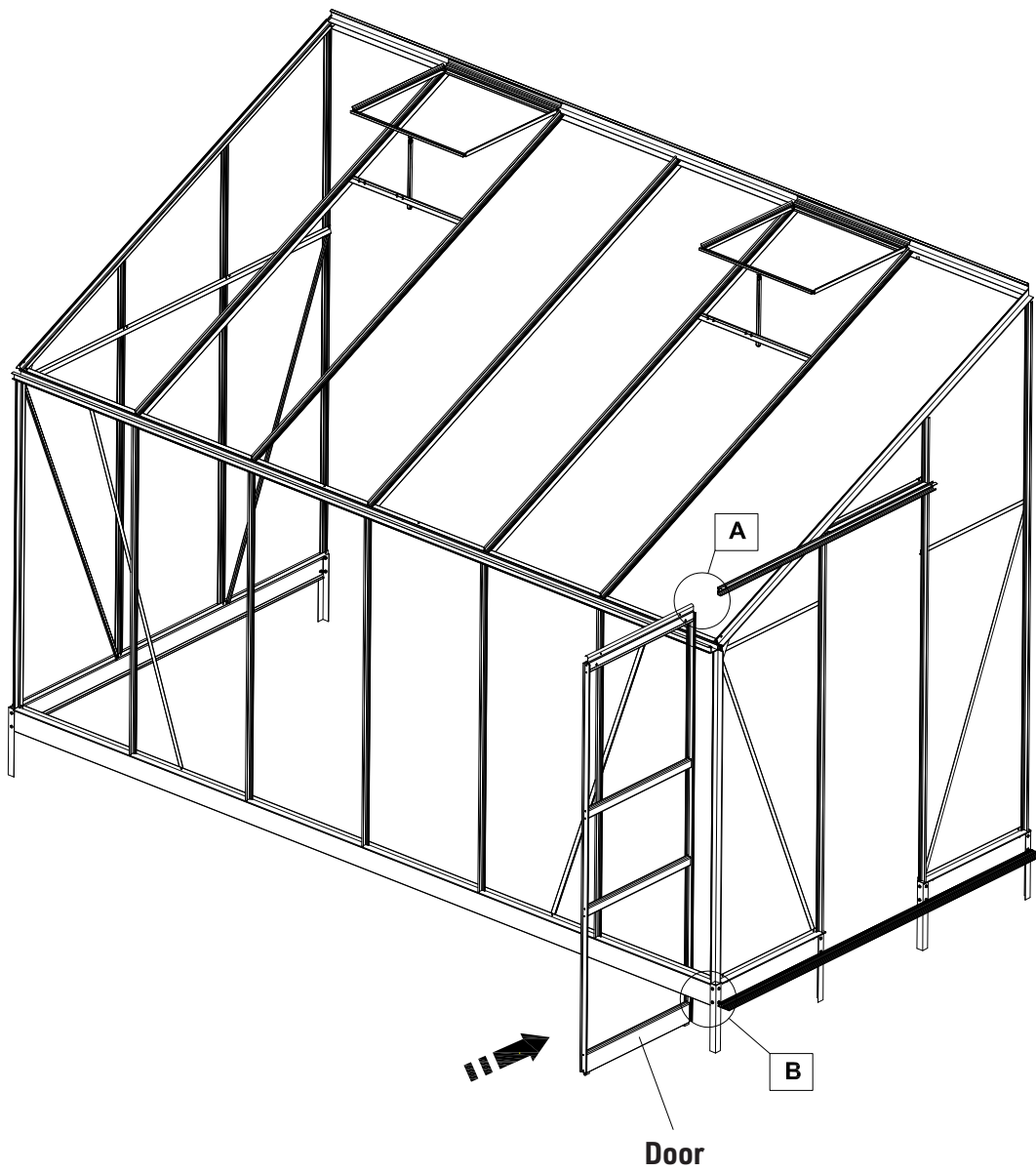

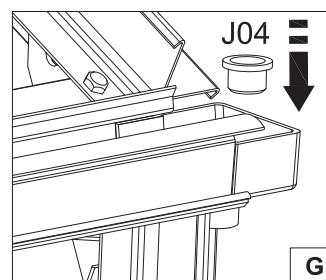
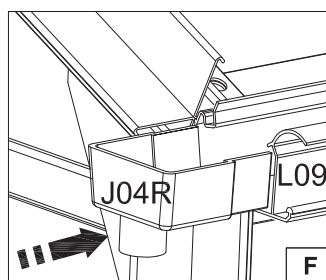
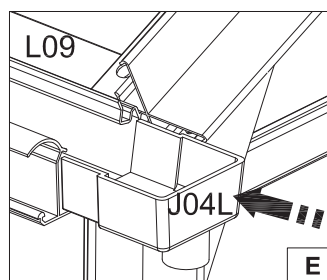
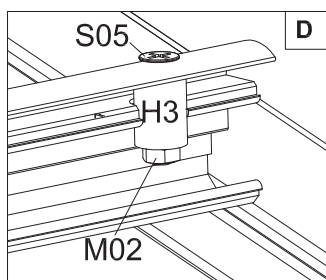
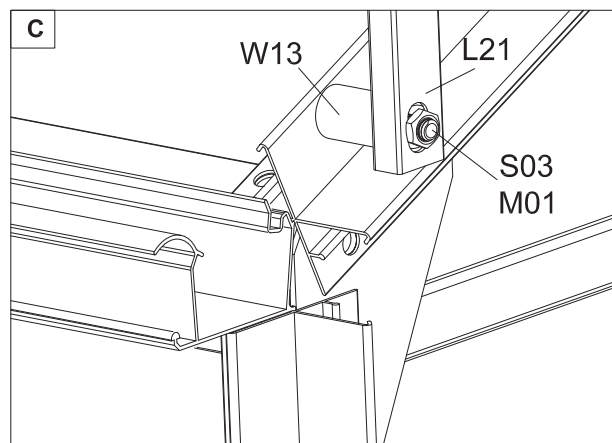
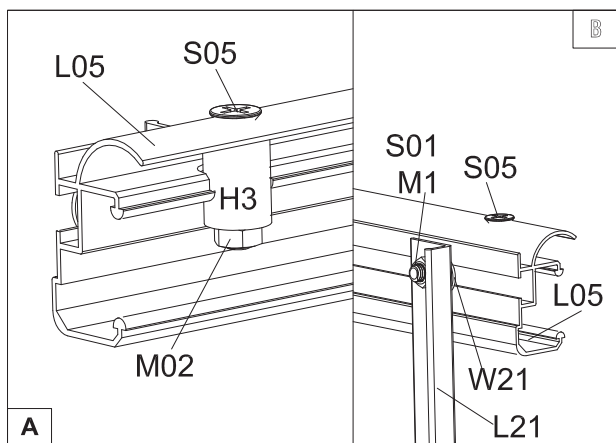
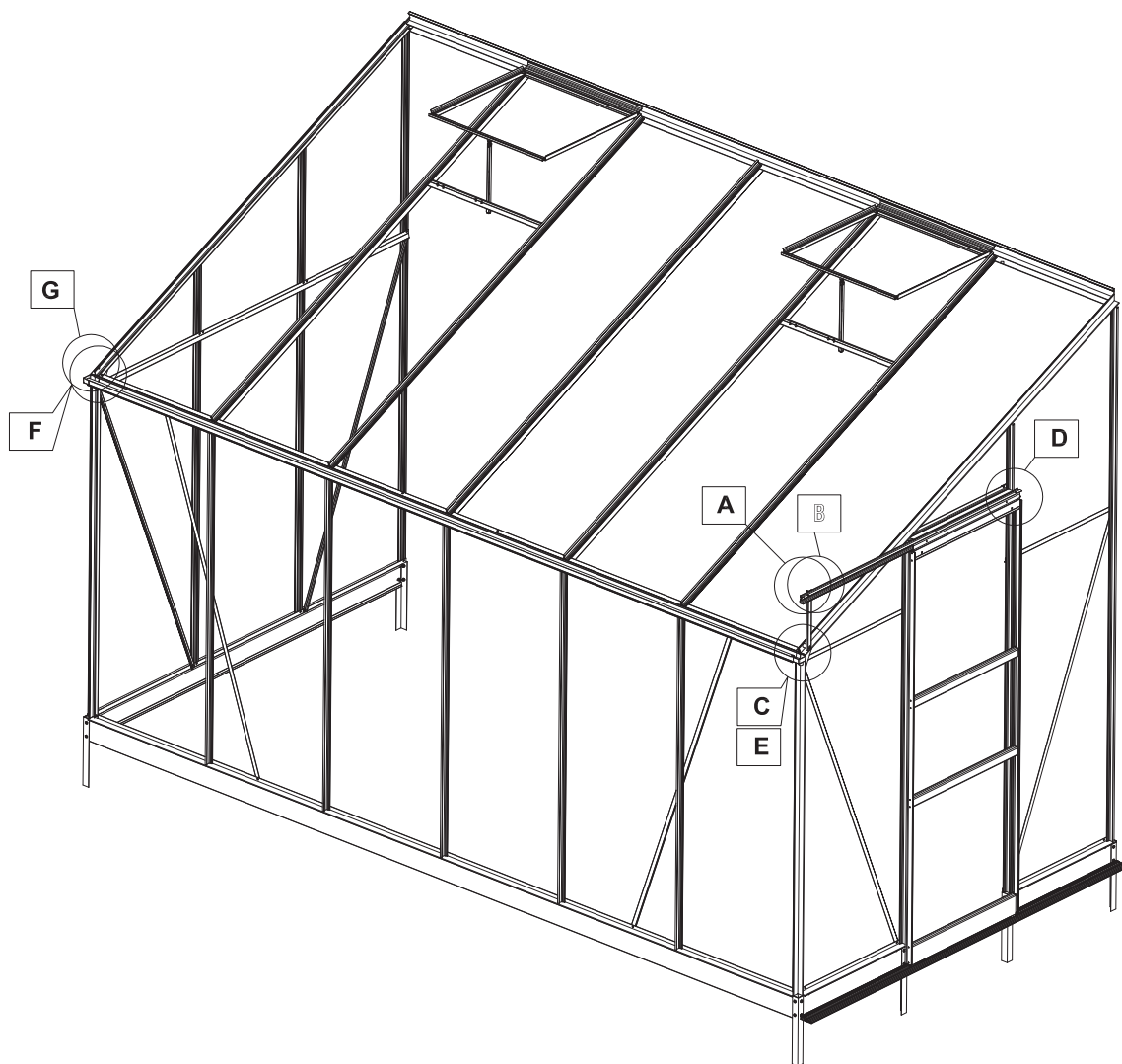

Sehr geehrter Kunde,  
wir gratulieren Ihnen zum Kauf Ihres Gewächshauses. Bitte lesen Sie die folgenden Anweisungen sorgfältig durch, bevor Sie mit der Montage beginnen.

**Hinweis: Stellen Sie vor dem Aufbau des Gewächshauses sicher, dass mögliche Gefahrenquellen wie unterirdische oder oberirdische Kabel oder Rohre usw. auffindig gemacht werden.**



### Aufstellort

- ☑ Ein sonniger, offener, nach Norden ausgerichteter Standort, der vor starkem Wind geschützt ist, ist der ideale Ort, um das Beste aus Ihrem Gewächshaus herauszuholen.
- ☑ Ihr Gewächshaus sollte auf einem flachen, ebenen Boden stehen. Sie haben verschiedene Optionen für die Erstellung des Fundaments, damit dieses Ihren Bedürfnissen gerecht wird. Die Gewächshäuser werden mit einem Fundamentrahmen geliefert, was die meisten Montageanforderungen erfüllt.
- ☑ Der Wasser- und Stromzugang sollte bereits im Vorfeld berücksichtigt werden, bevor ein solides Fundament gelegt wird.

### Errichtung





- ☑ Wir raten Ihnen, genügend Platz rund um das Gewächshaus zu schaffen, damit es während der Montage und auch für spätere Wartungsarbeiten leicht zugänglich ist.
- ☑ Montieren Sie den Aluminiumrahmen (ohne Verglasung) und positionieren Sie ihn am Aufstellort. So können Sie die genaue Position der Pfostenlöcher für die Verankerung ermitteln und markieren.
- ☑ Sobald Sie Ihre Ankerposition markiert haben, versetzen Sie den Gewächshausrahmen, damit die Löcher ausgehoben werden können.
- ☑ Es wird eine Mindesttiefe von 60cm und ein Durchmesser von 20cm empfohlen.
- ☑ Sobald die Ankerpfähle an dem Rahmen befestigt sind, können Sie das Gewächshaus über die Löcher anheben und anschließend absenken.
- ☑ Wenn Sie mit der finalen Position zufrieden sind und sichergestellt haben, dass der Rahmen rechteckig, eben und waagrecht ist, kann der Beton in die zuvor ausgehobenen Ankerlöcher gegossen werden.





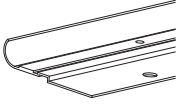
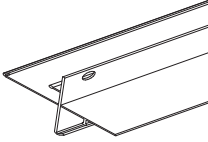
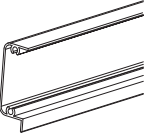
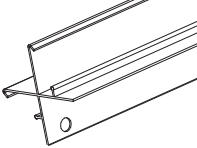
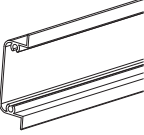
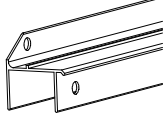
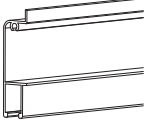
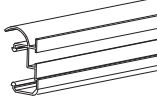
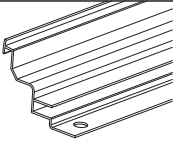
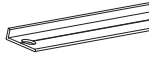
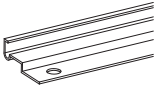
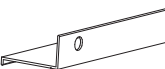
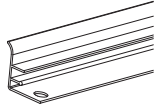
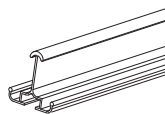
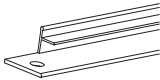
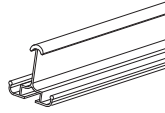
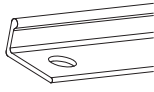
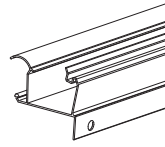
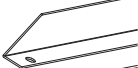
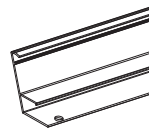

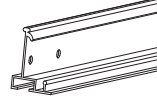



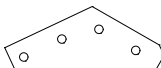

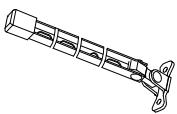

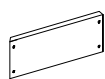



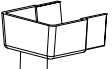

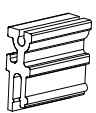
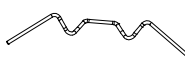
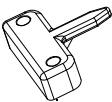

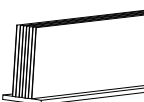

### Befestigung auf einer soliden Grundfläche

- ☑ Verwenden Sie den in der Aufbauanleitung enthaltenen Plan für das Fundament als Anleitung für den Bau Ihres soliden Fundaments (Holz, Ziegel, Beton, ...). Die Befestigungen befinden sich im Inneren des 43mm Aluminiumrahmens etwa 55mm nach innen versetzt.

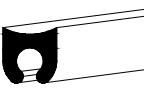
### Verglasung

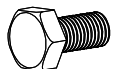
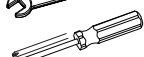
- ☑ Nach dem Aufbau und der Platzierung des Aluminiumrahmens kann mit der Verglasung begonnen werden.
- ☑ Obwohl es sich bei allen Gläsern um Sicherheitsglas handelt, sollten sie immer als potentielle Gefahr angesehen und somit mit Vorsicht gehandhabt werden. Vergewissern Sie sich, dass der Rahmen frei von Verschmutzungen ist, bevor Sie mit der Verglasung beginnen. Vermeiden Sie die Verglasung bei Wind.
- ☑ Sollten Sie die Scheiben während der Verglasung neben das Gewächshaus stellen wollen, empfehlen wir Ihnen, diese leicht schräg anzulehnen.
- ☑ Beginnen Sie mit den Dachscheiben und arbeiten Sie sich dann von einem Ende ans andere vor.
- ☑ Lehnen Sie sich zum Einsetzen der Dachscheiben gegen die Dachrinnen und schieben Sie die Scheiben zwischen den Verstärkungsstäben durch, bis sie den Dachfirst erreichen.
- ☑ Schieben Sie die Wandpaneele schräg zwischen den senkrechten Aluminiumstäben durch nach oben bis in den Falz unter der Dachrinne.
- ☑ Achten Sie darauf, dass die Unterseite der Glasscheibe richtig auf dem Gestell aufliegt.
- ☑ Das Paneel sieht rechteckig und lotrecht aus und wird durch die Nut an der Unterseite und den Falz an der Oberseite gesichert.
- ☑ Setzen Sie die Gummidichtungen mit Daumen und Zeigefinger als Führung ein. Alle Gummis sind länger als notwendig und sollten bei der Montage zugeschnitten werden.
- ☑ Wenn das Gummiprofil trocken erscheint, verwenden Sie Seifenwasser, um den Einbau in die Leisten zu erleichtern.
- ☑ Die Dichtungen sollten nach der Fertigstellung flach und gerade aussehen. Lassen Sie die Gummis ein oder zwei Stunden ruhen, bevor Sie diese zuschneiden, da sie sich während des Einsetzens dehnen und dann wieder zusammenziehen könnten. Schneiden Sie die Gummis erst dann zurecht, wenn alle eingesetzt wurden.

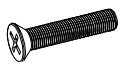
Teil	#	mm	Anzahl	Teil	#	mm	Anzahl
	L12	640	1		L01A L01B	2073 2073	1 1
	L13A	640	1		L01C L01D	1474 1474	1 1
	L13B	640	2		L04	592	1
	L38	640	1		L05	1300	1
	L15	602	2		L06A L06B L06C L06D	1547 620 640 1558	4 1 1 2
	L16	602	2		L07A L07B L07C L07D	1869 3706 626 646	1 1 1 1
	L17	700	4		L08A L08B L08C L08D	2358 2358 1780 1780	1 1 1 1
	L18	638	2		L08E L08F L08G L08H	1474 2046 2069 2069	5 5 1 1
	L21	259	1		L09	3708	1
	L22	1865	1		L10	3708	1
	L23	2042	5		L11A L11B	1816 1816	1 1
	L37	1842	1				

Teil	#	mm	Anzahl	Teil	#	mm	Anzahl
	M01	M6	113		W2		2
	M02	M5	2				
	Z01	Ø4*16	24		W5		2
	Z02	Ø4*6	4				
	H3		2		W07A	655	1
					W07B	645	1
					W07C	3758	1
					W07D	1900	1
	J04		1		W08	350	6
					W09		13
	J04L		1		W11		20
	J04R		1		W13	Ø12*28	3
	J11		2		W14		210
	J13		4		W15		6
					W21	Ø12*Ø6*1.5	2
	J15	Ø6.5*20	4		W16		1
					W17		1
	J18	1.82M	2		W46		2
	J19	78M	1				
	T01		1		S01	M6*10	90
	T02		1		S02	M6*16	24
					S03	M6*40	3
					S04	M6*14	5
					S05	M5*25	2
	S04				S07	M6*60	12

**Wichtiger Hinweis:**  
 Sie brauchen nicht alles zu demontieren, wenn Sie vergessen haben, die S01-Schrauben einzubauen, Sie können sie durch die S04-Schrauben ersetzen!



## Montage des Fundaments

Es ist wichtig, dass das Fundament des Gewächshauses perfekt quadratisch ist, so dass die diagonalen Maße identisch sind. Das Gewächshaus muss außerdem an der Vorder- und Rückseite gleichmäßig waagrecht und perfekt lotrecht sein.

Die Verankerung des Gewächshauses im Boden ist unerlässlich. Wir empfehlen die Verwendung von Mauerwerksankern, wenn Sie eine Beton- oder Steinplatte als Fundament haben. In diesem Fall müssen Sie die Ankerhalterungen zuschneiden.

Alternativ können die Anker auch in den Boden einbetoniert werden (Fundament mit einem Durchmesser von mindestens 300mm und einer Tiefe von 400mm). Oft ist es am besten, dies am Ende der Montage vorzunehmen. Befestigen Sie die Struktur während der Bauarbeiten immer vorübergehend.

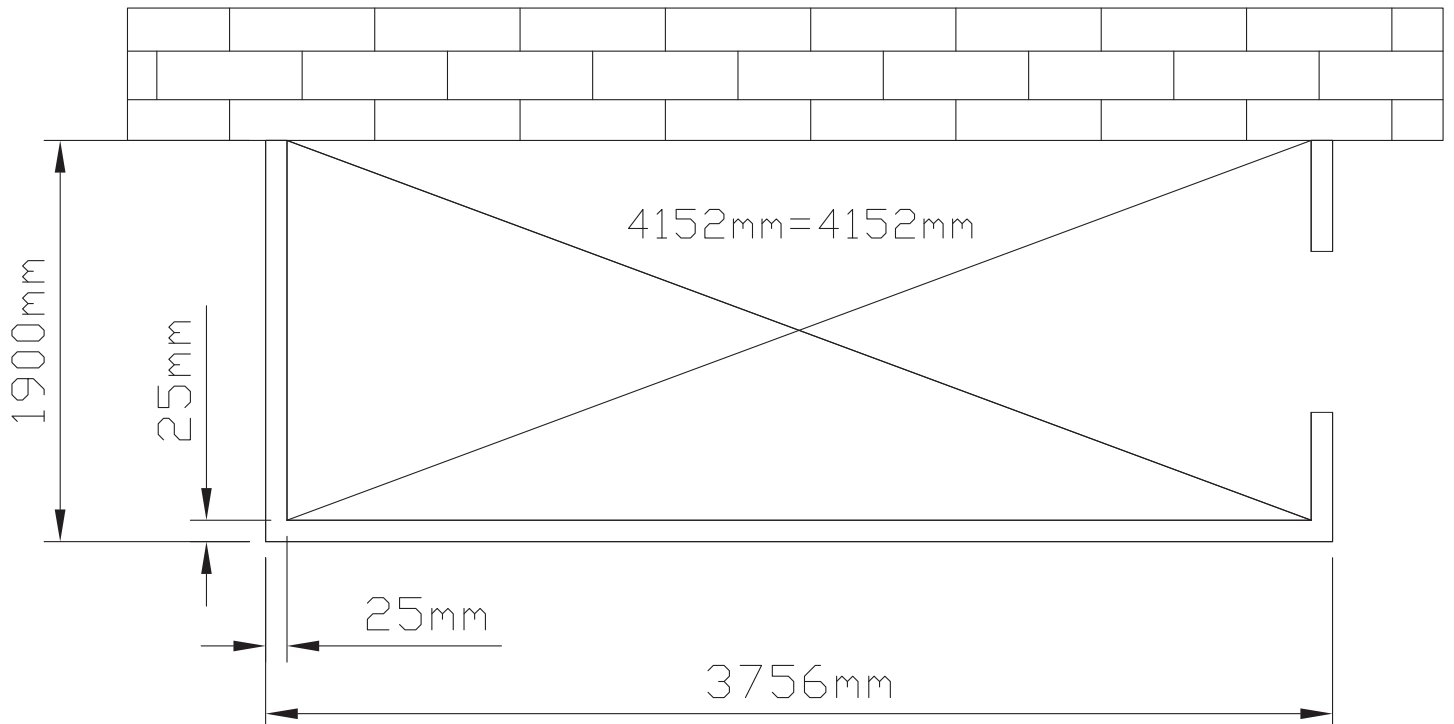
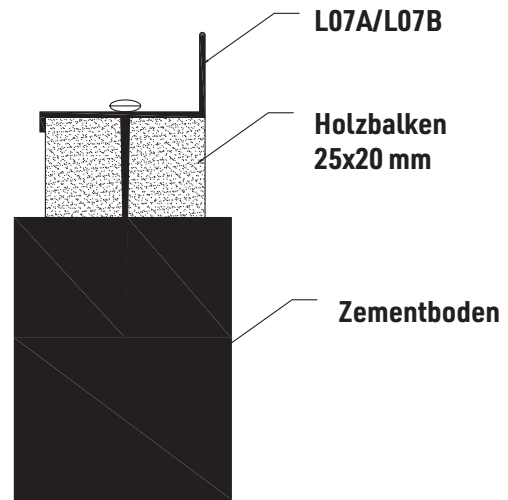

# Montage Rahmen

**Hinweis:** Bitte entfernen Sie die Schutzfolie auf der Oberfläche der Teile W08 und W07 A (B/C/D) bevor Sie mit der Montage des Rahmens beginnen

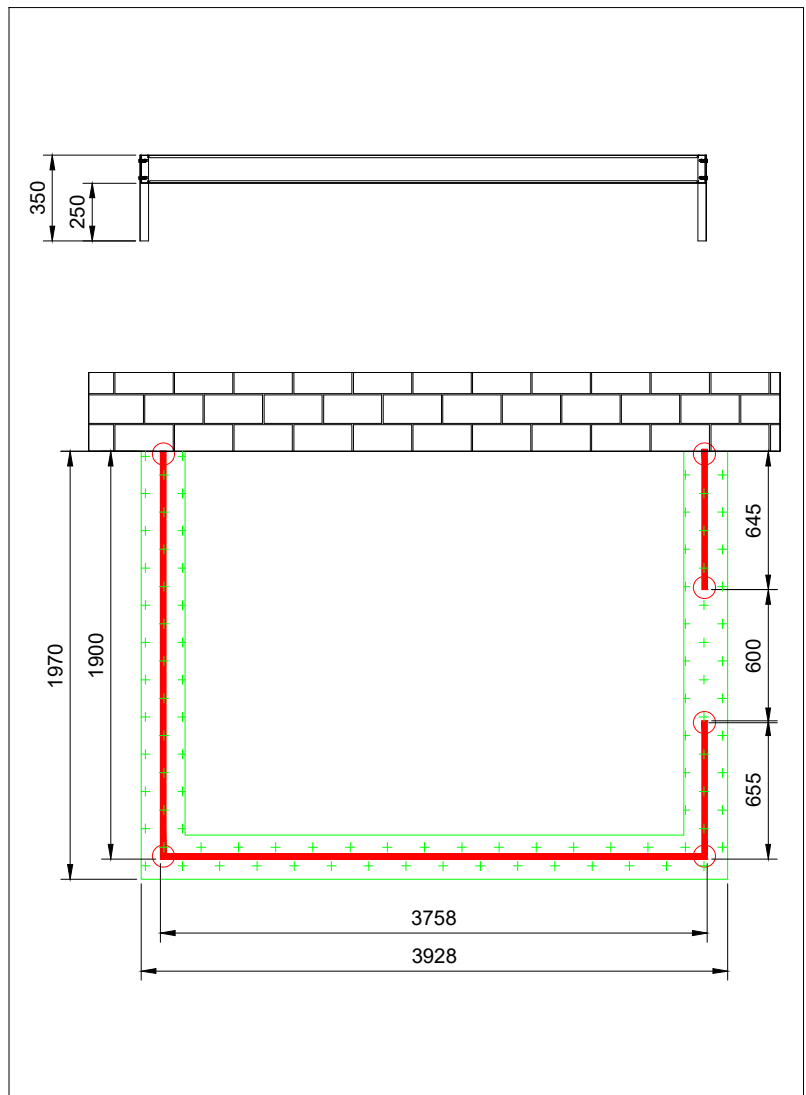
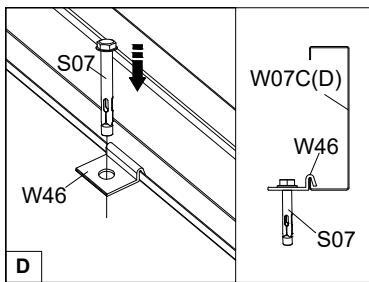
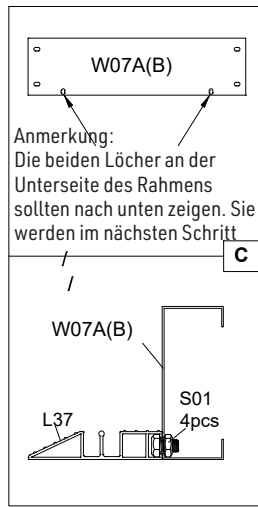
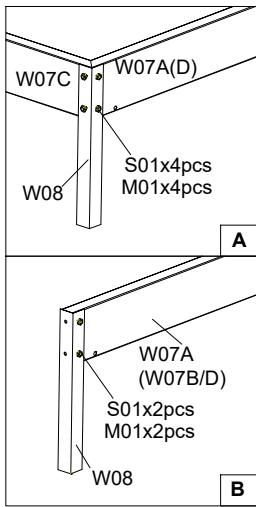
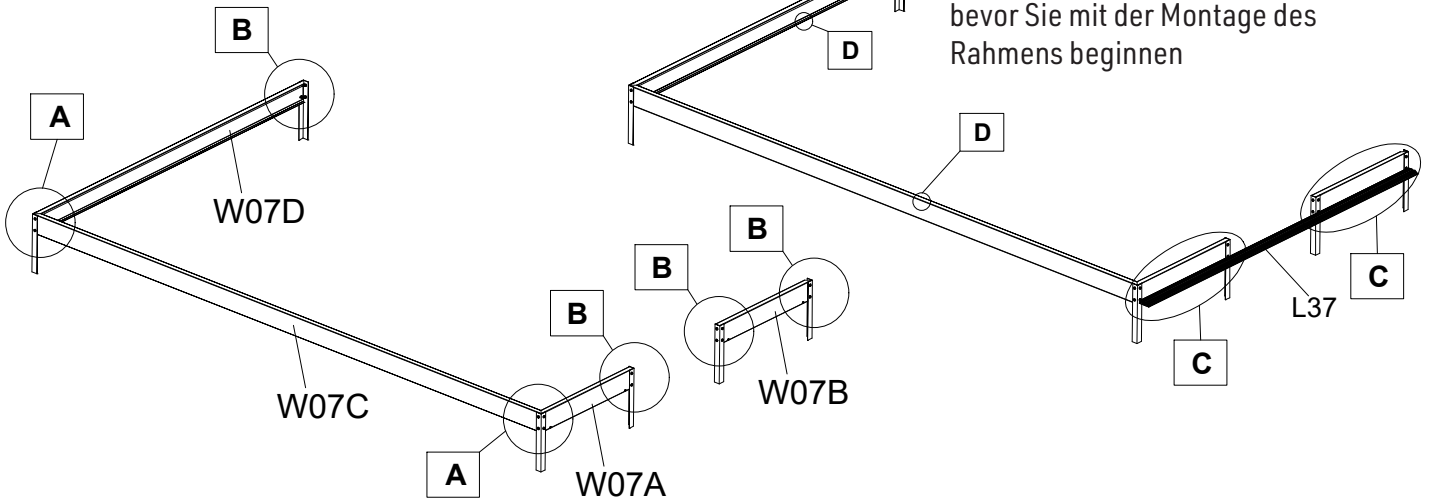

# Montage der Tür

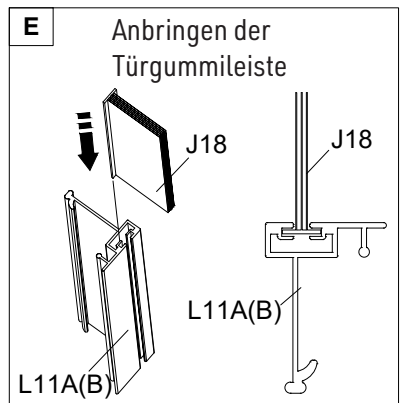
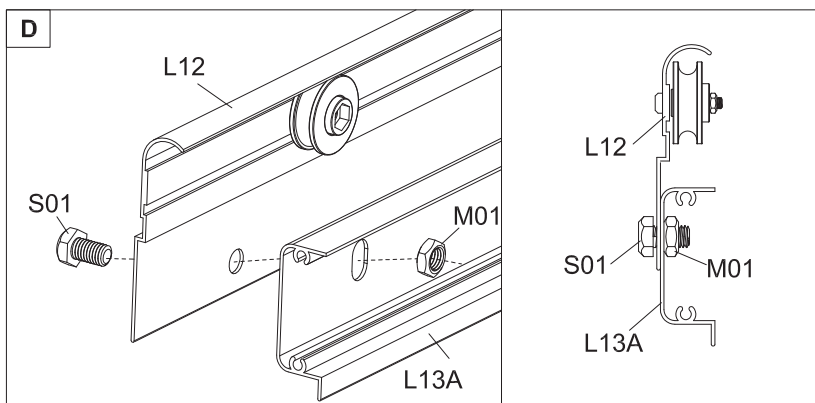
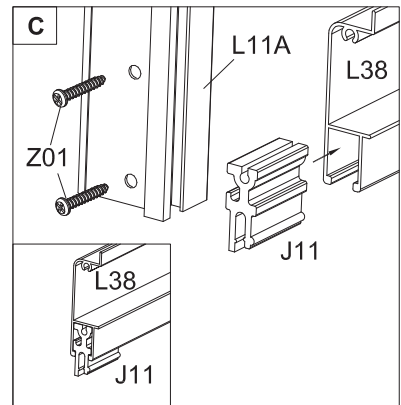
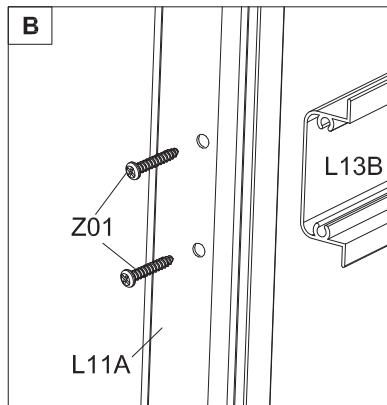
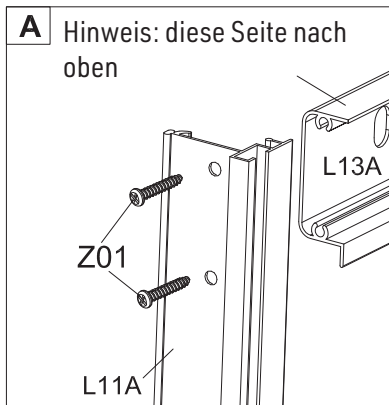
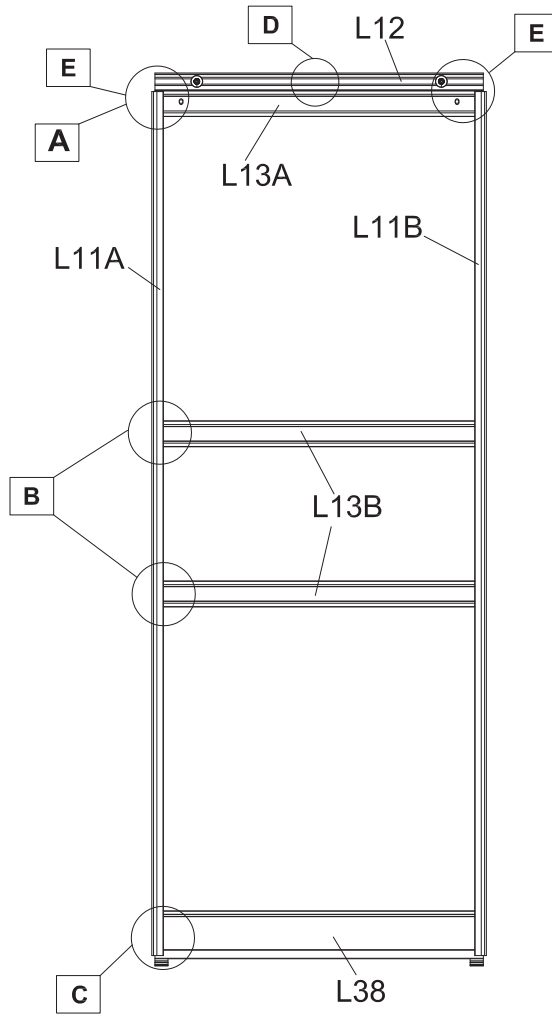

# Montage des Fensters

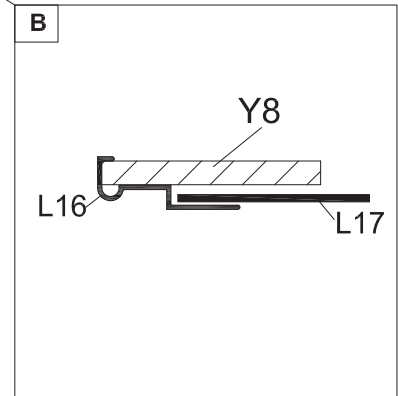
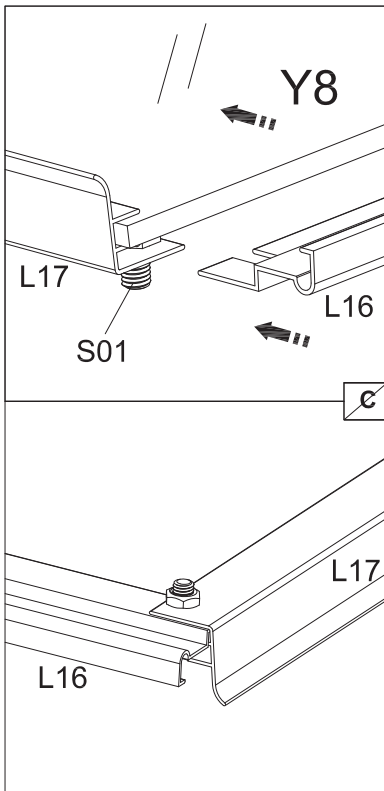
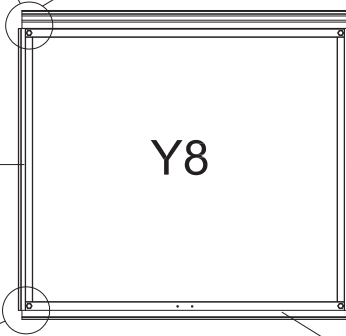
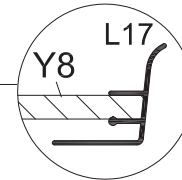
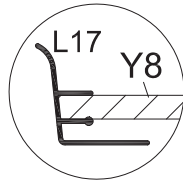
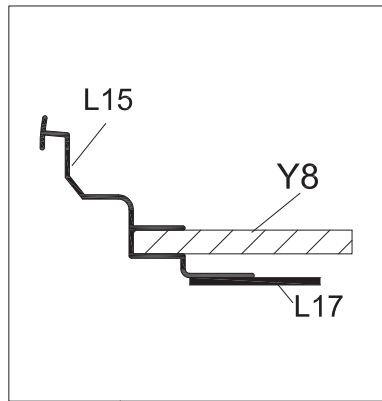
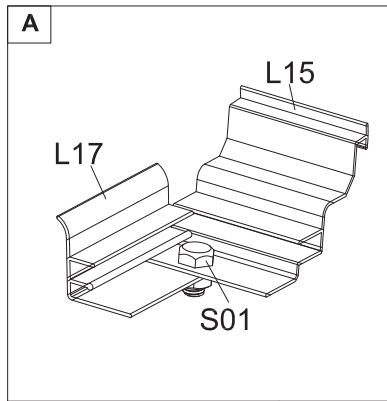

# Montage des vorderen Giebels

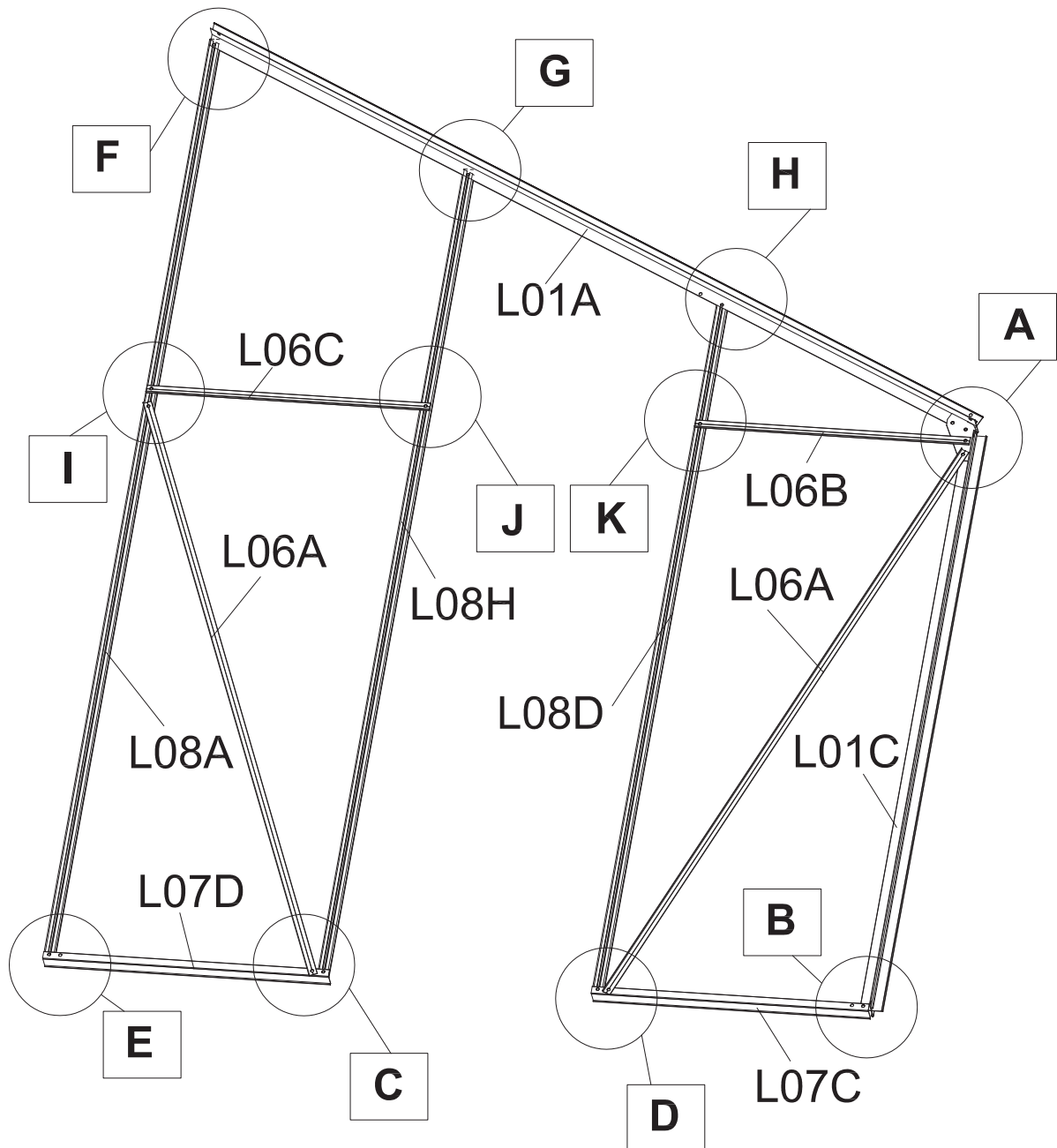

# Montage des vorderen Giebels

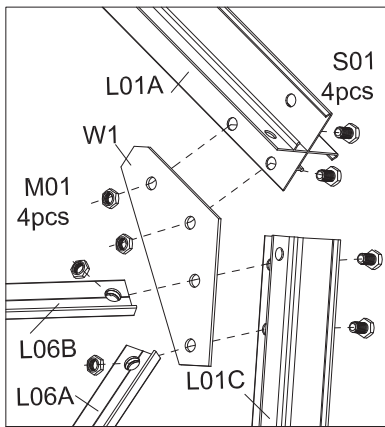

Ziehen Sie die Muttern erst an, wenn L09 montiert ist

**A**

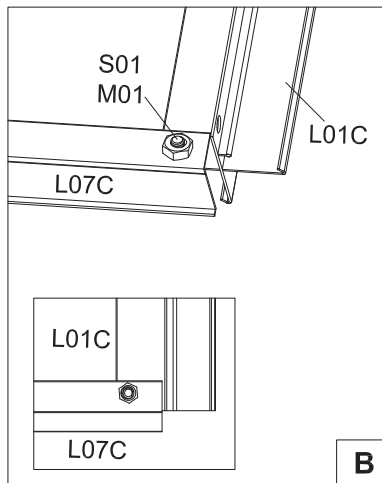

**B**

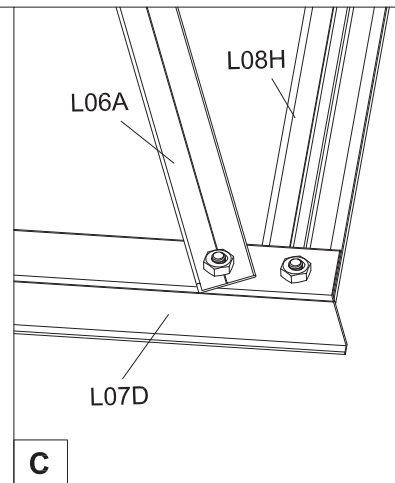

**C**

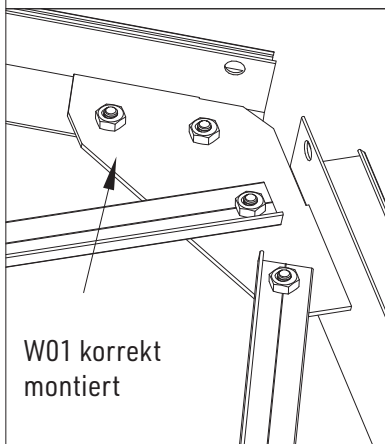

W01 korrekt montiert

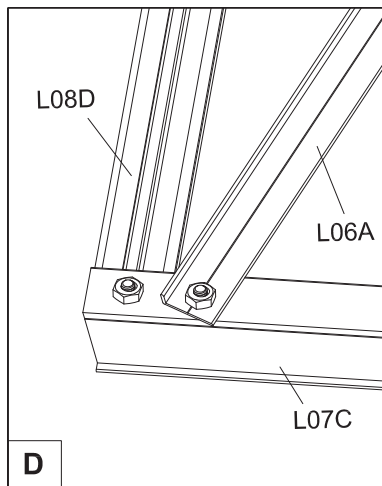

**D**

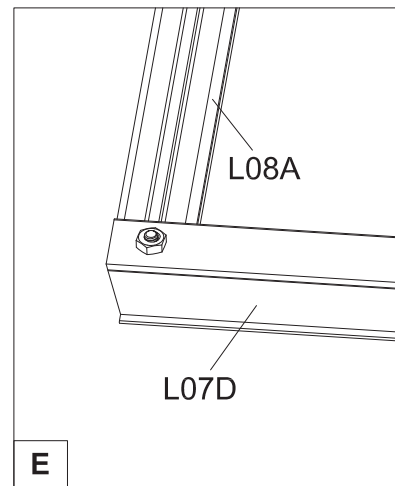

**E**

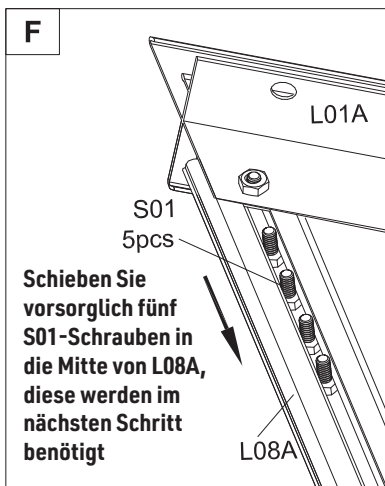

Schieben Sie vorsorglich fünf S01-Schrauben in die Mitte von L08A, diese werden im nächsten Schritt benötigt

**F**

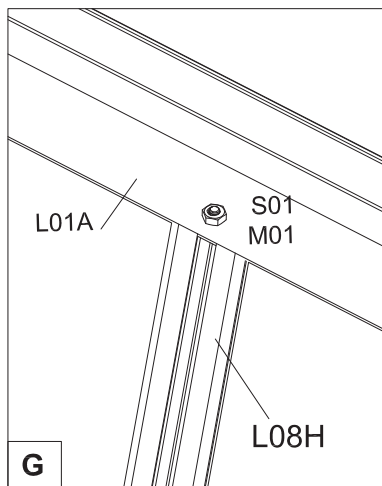

**G**

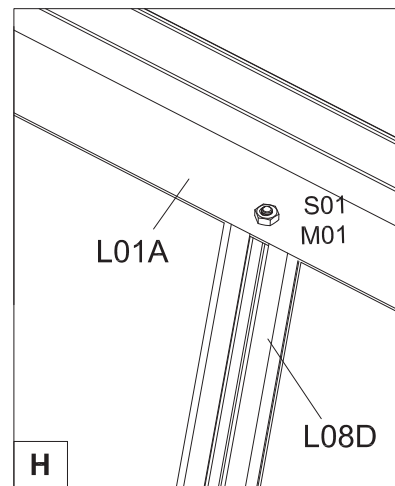

**H**

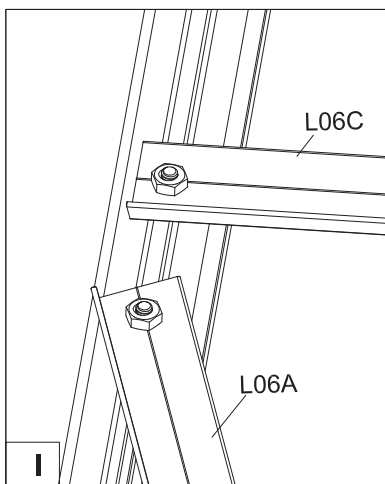

**I**

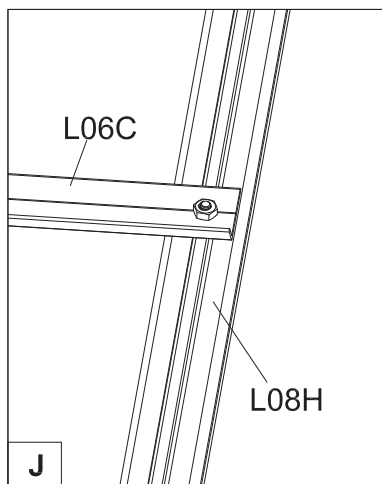

**J**

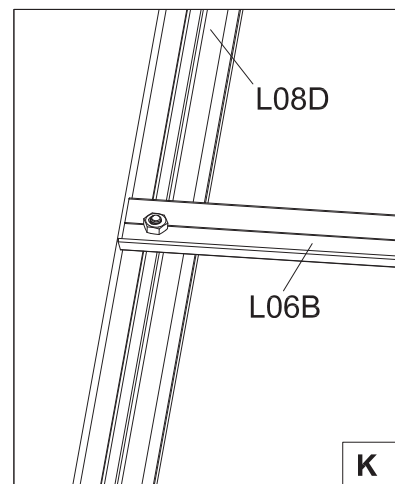

**K**



# Montage des vorderen Giebels

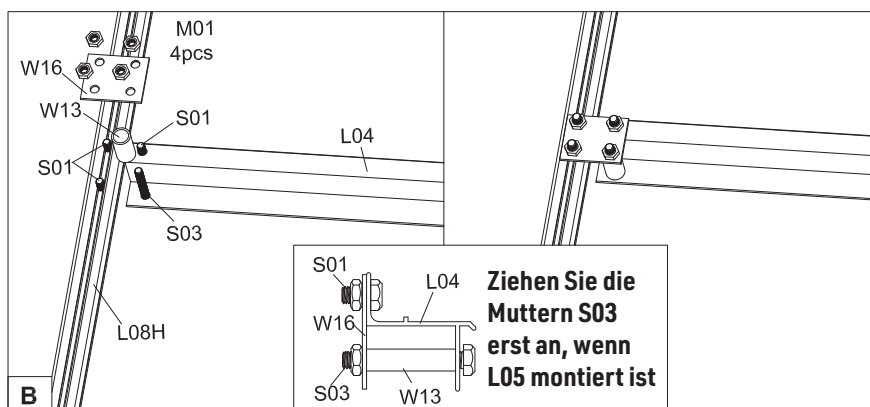
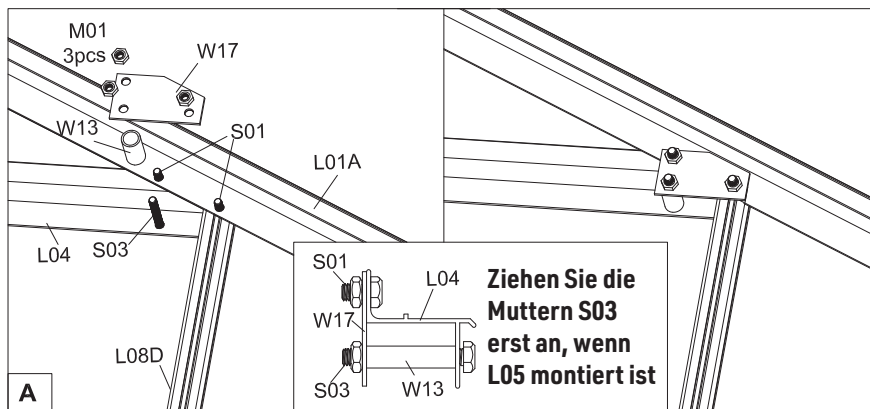
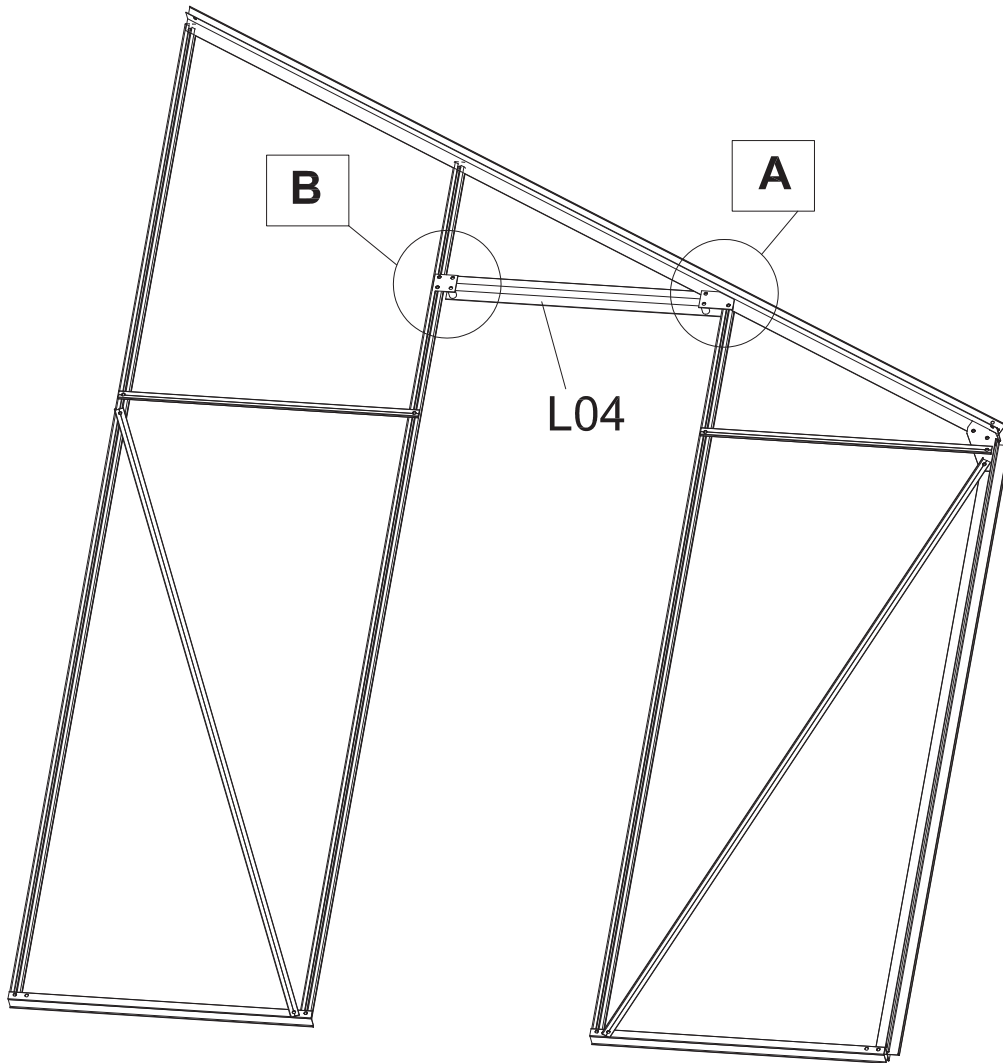

# Montage des hinteren Giebels

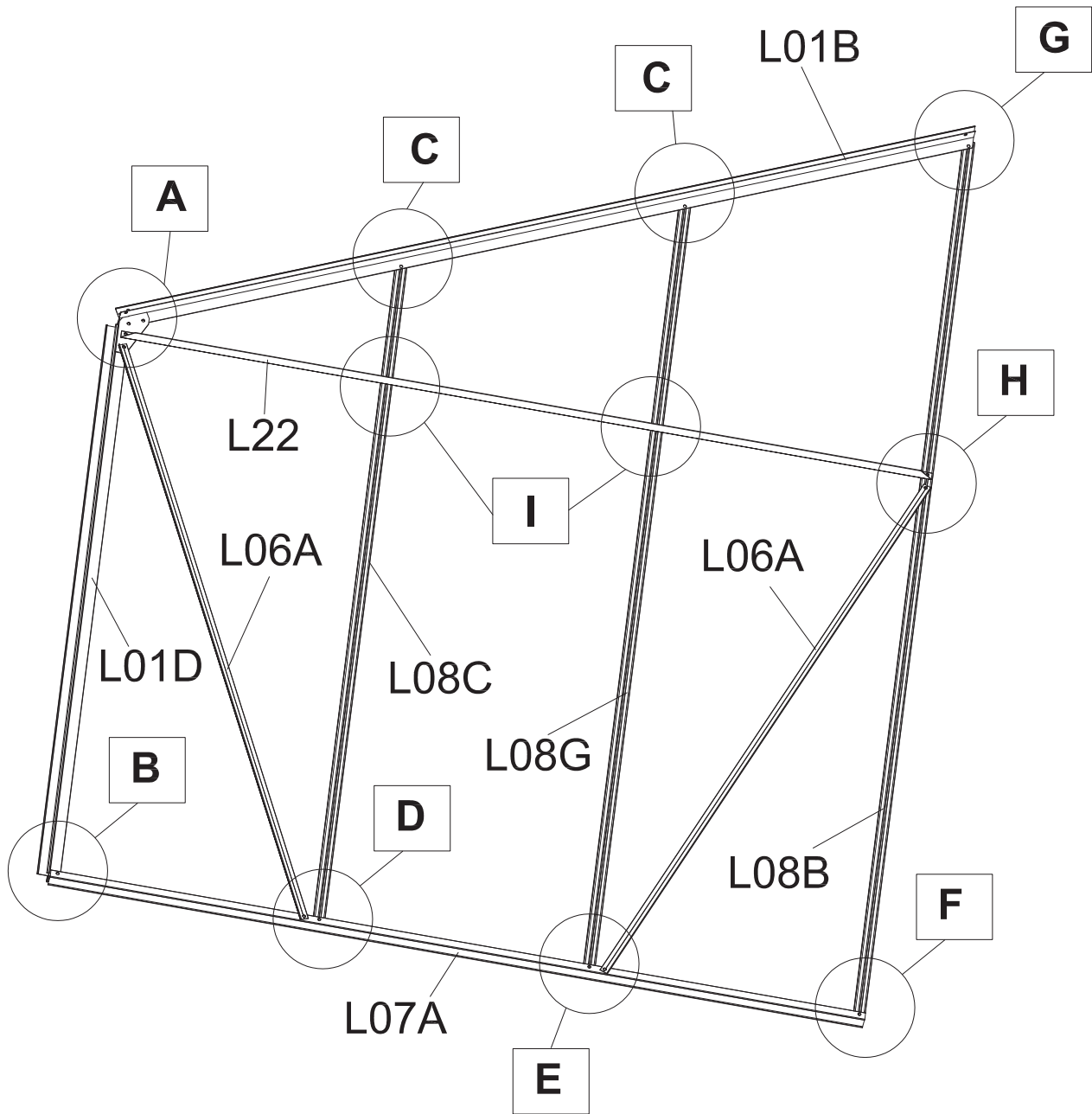

# Montage des hinteren Giebels

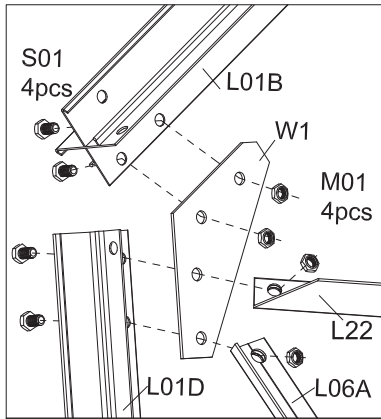

Ziehen Sie die Muttern erst an, wenn L09 montiert ist

**A**

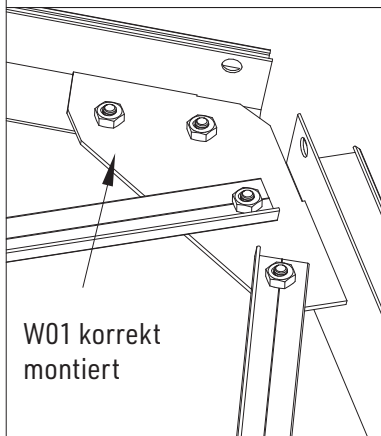

W01 korrekt montiert

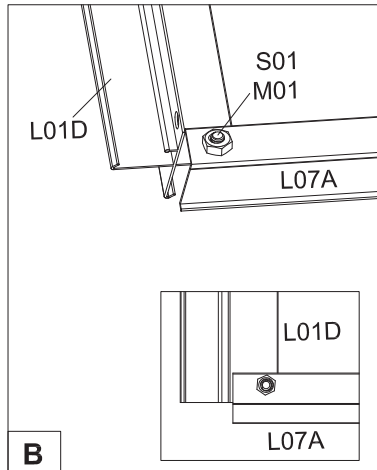

**B**

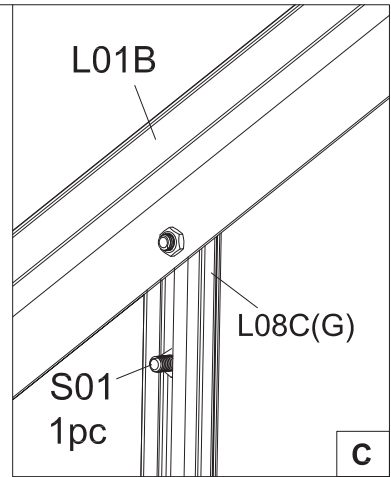

**C**

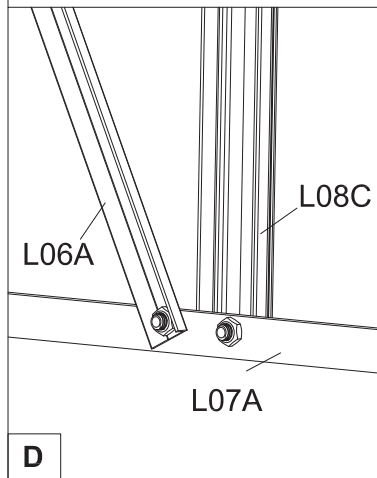

**D**

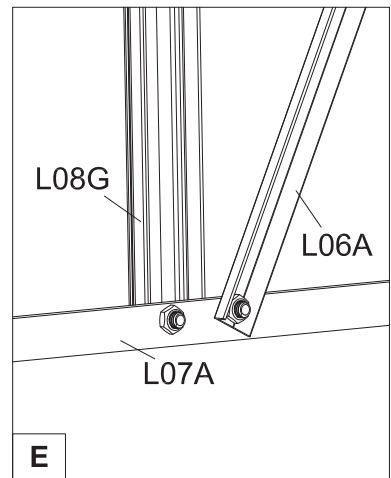

**E**

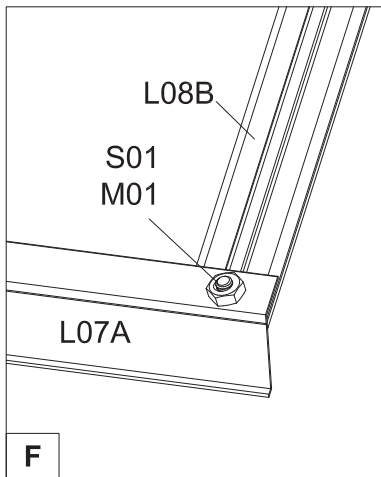

**F**

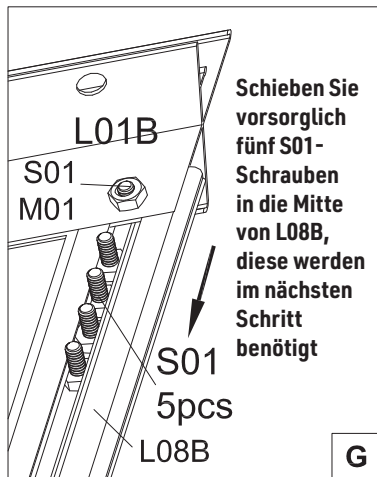

**G**

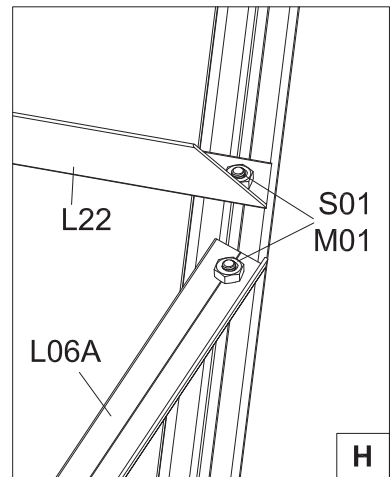

**H**

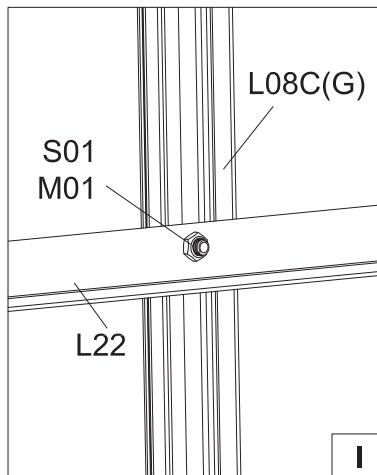

**I**

# Montage der Seitenwand

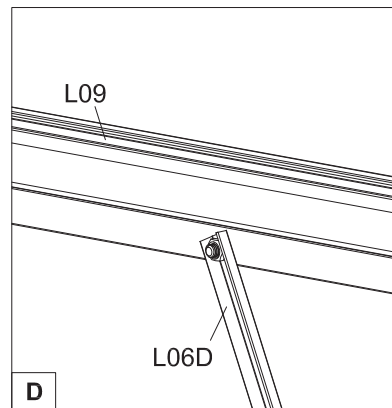
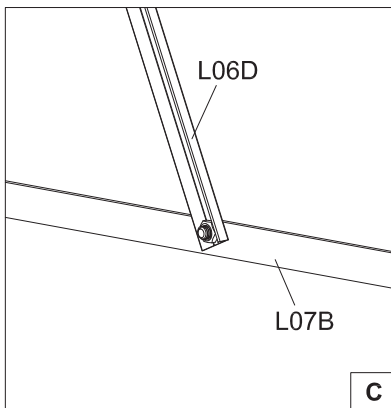
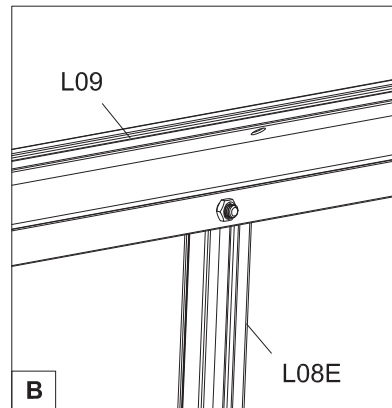
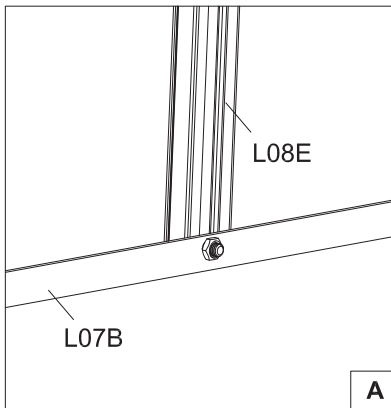
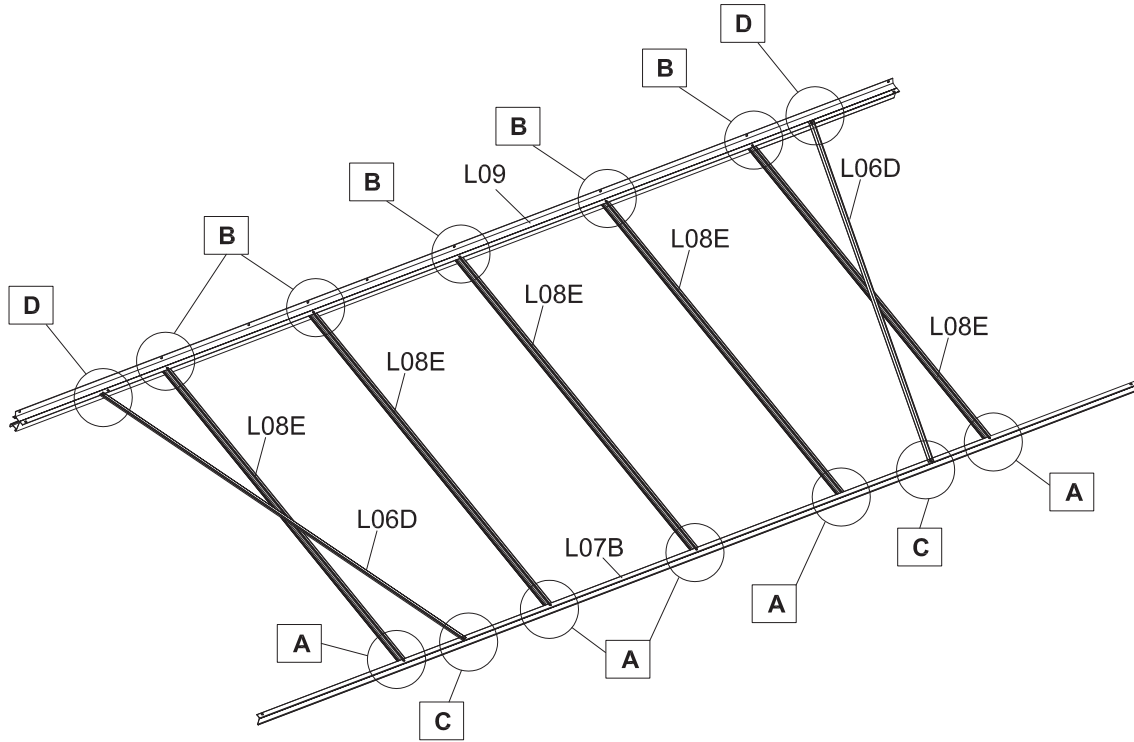

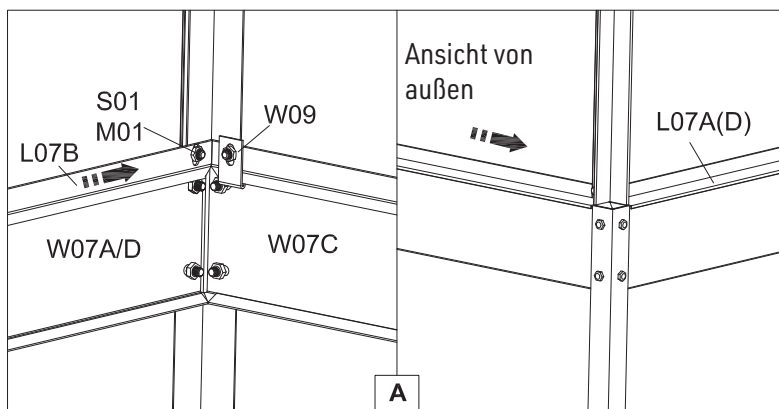
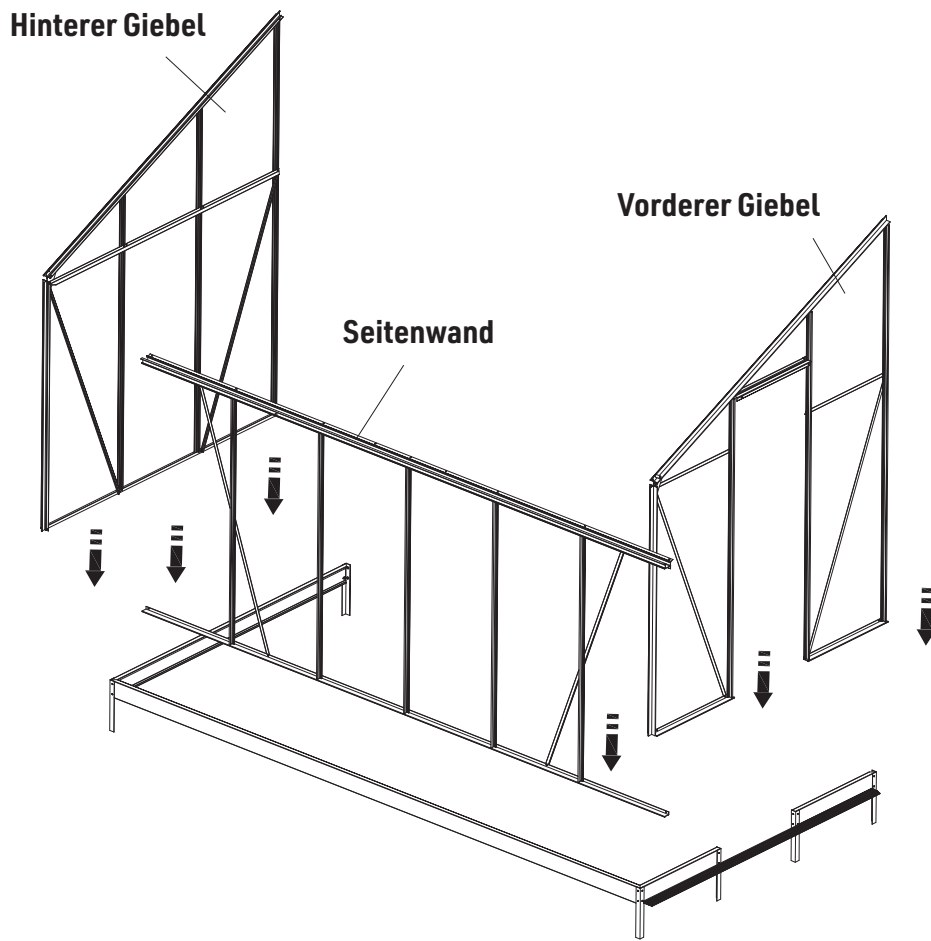

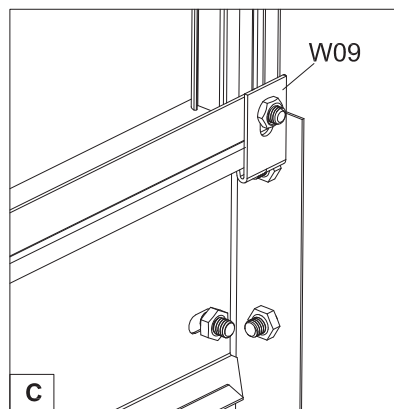
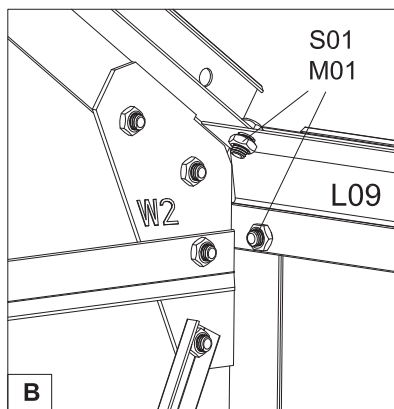
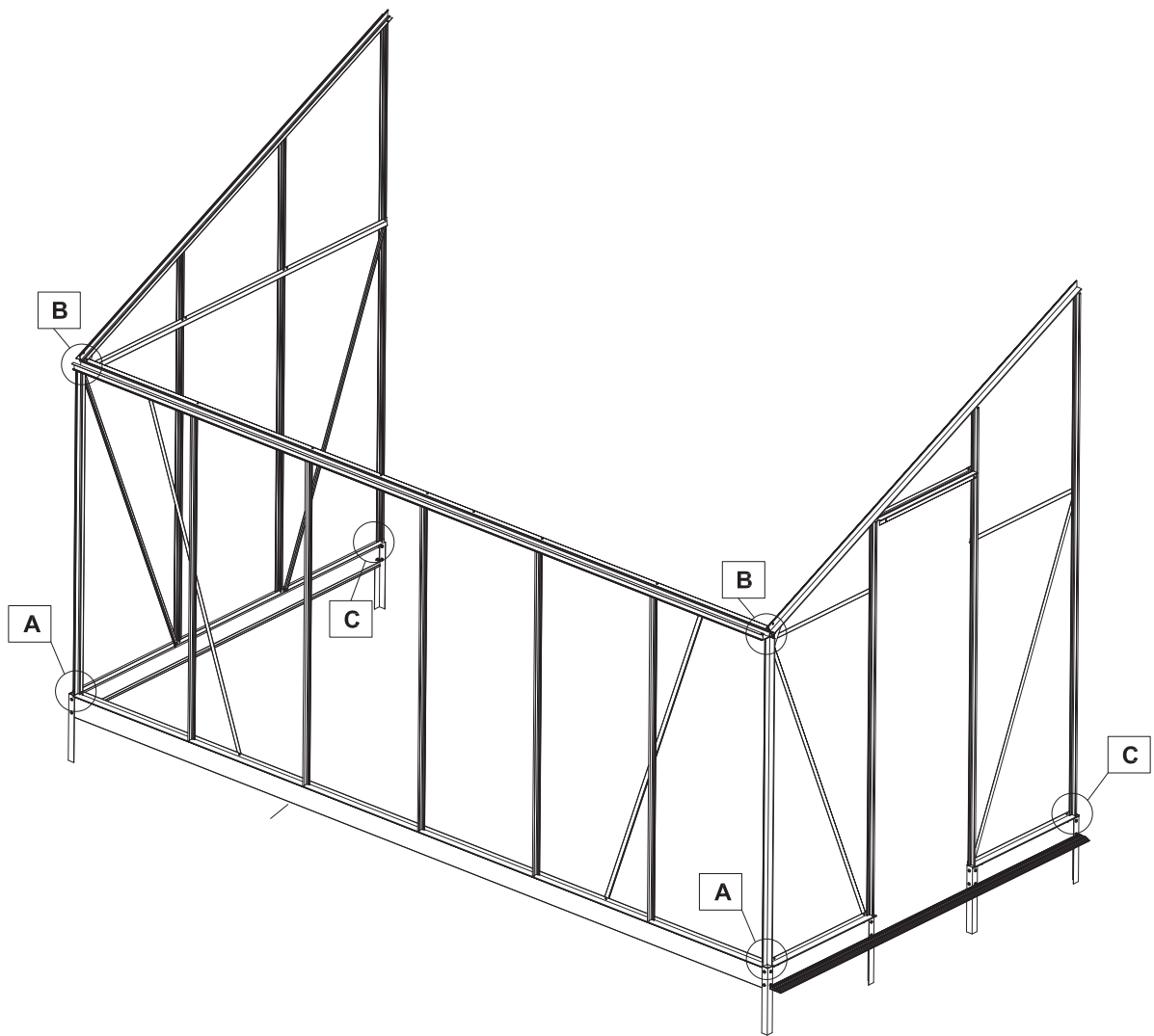

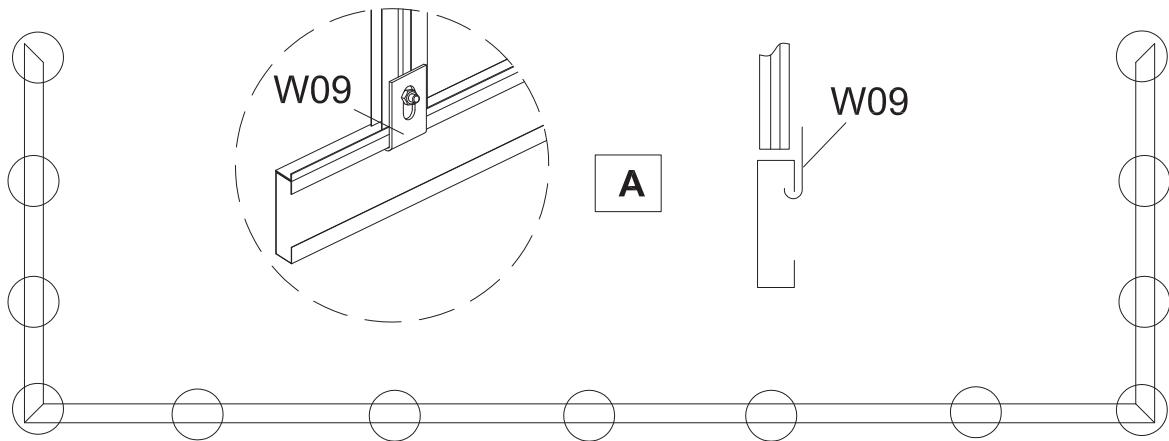
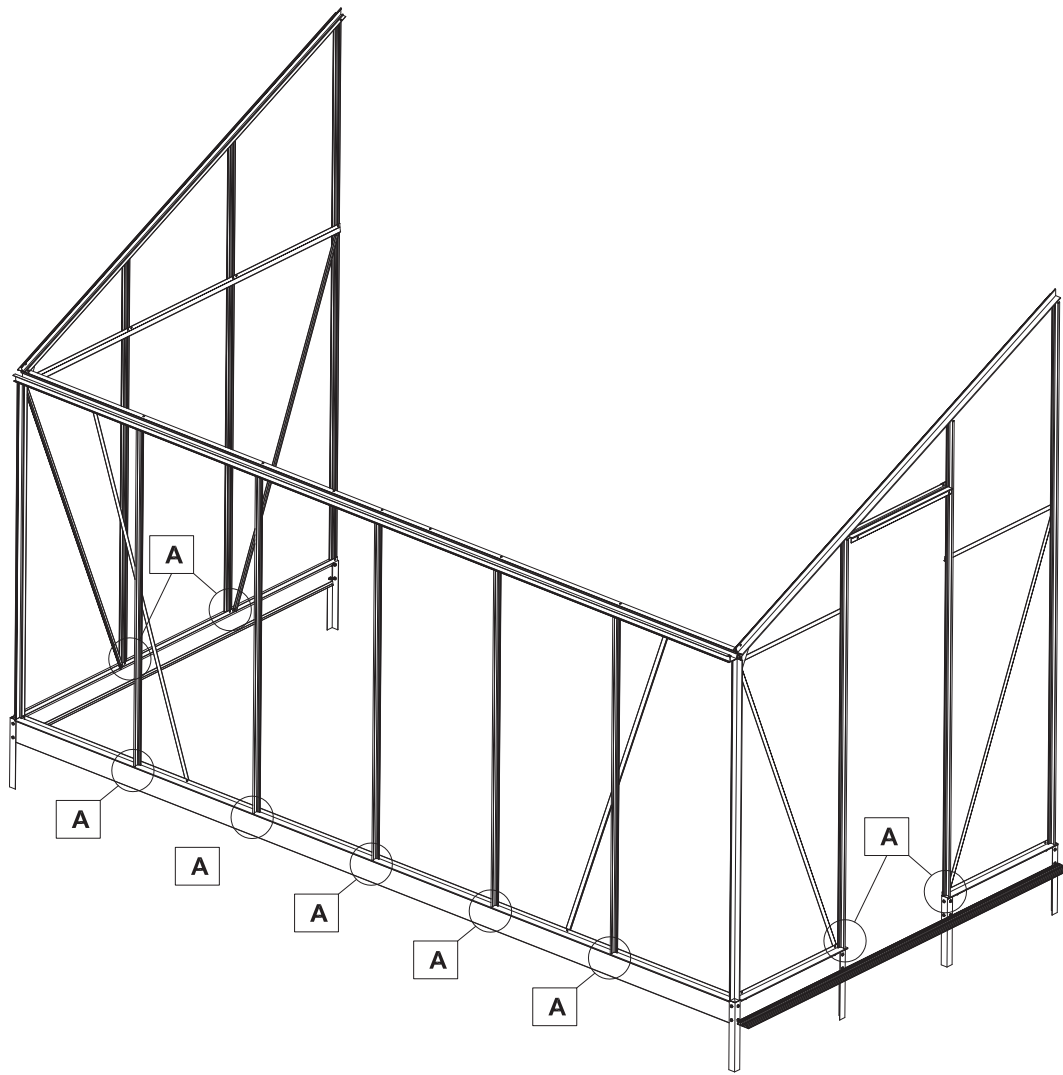

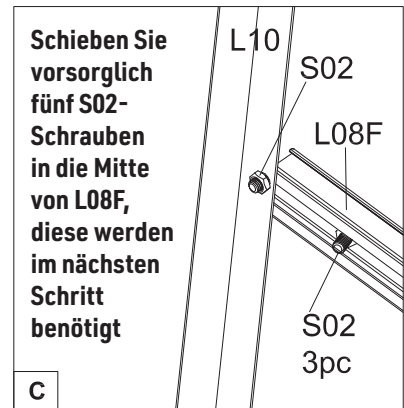
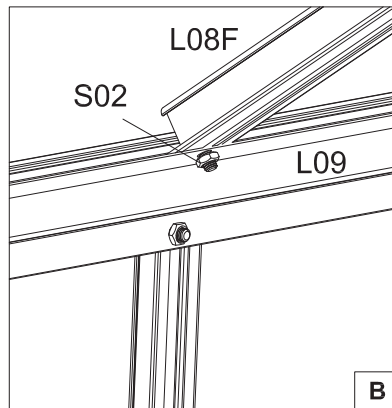
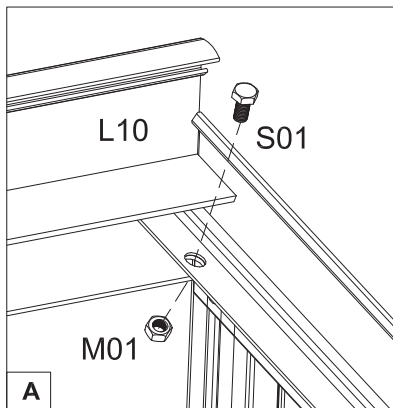
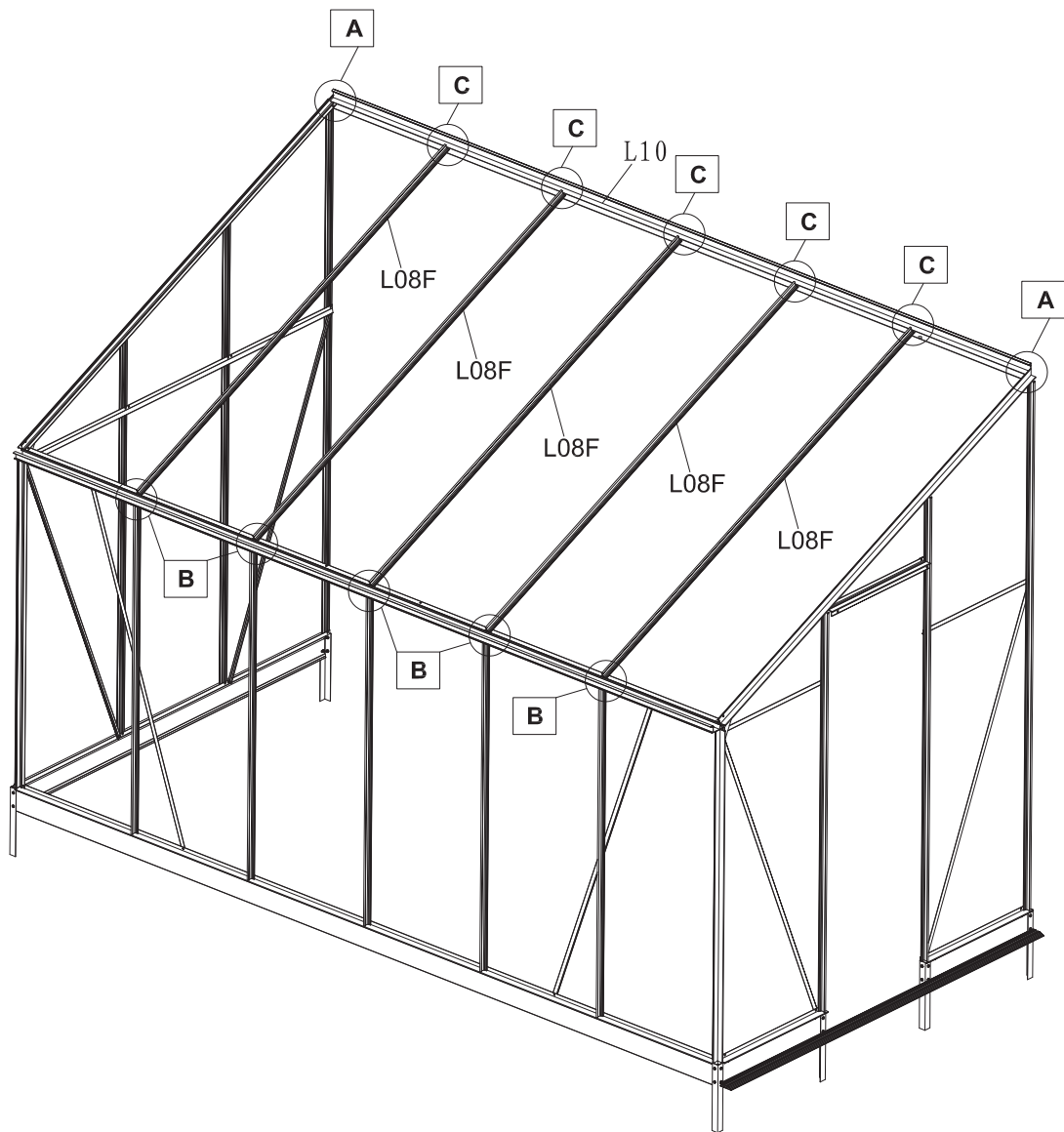

Schieben Sie vorsorglich fünf S02-Schrauben in die Mitte von L08F, diese werden im nächsten Schritt benötigt

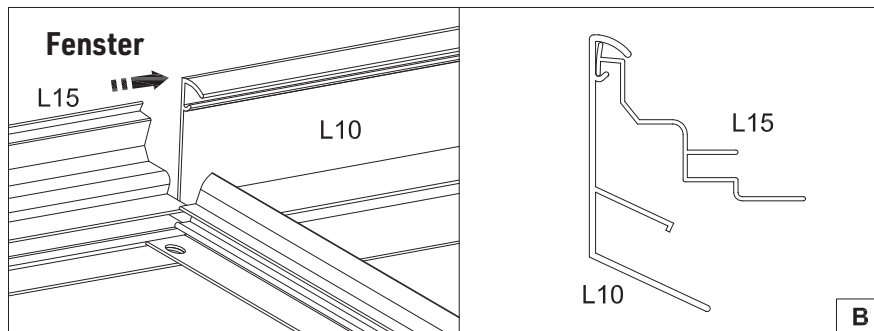
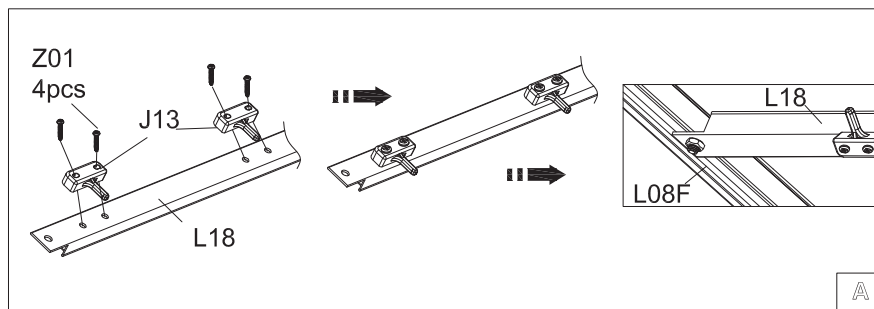
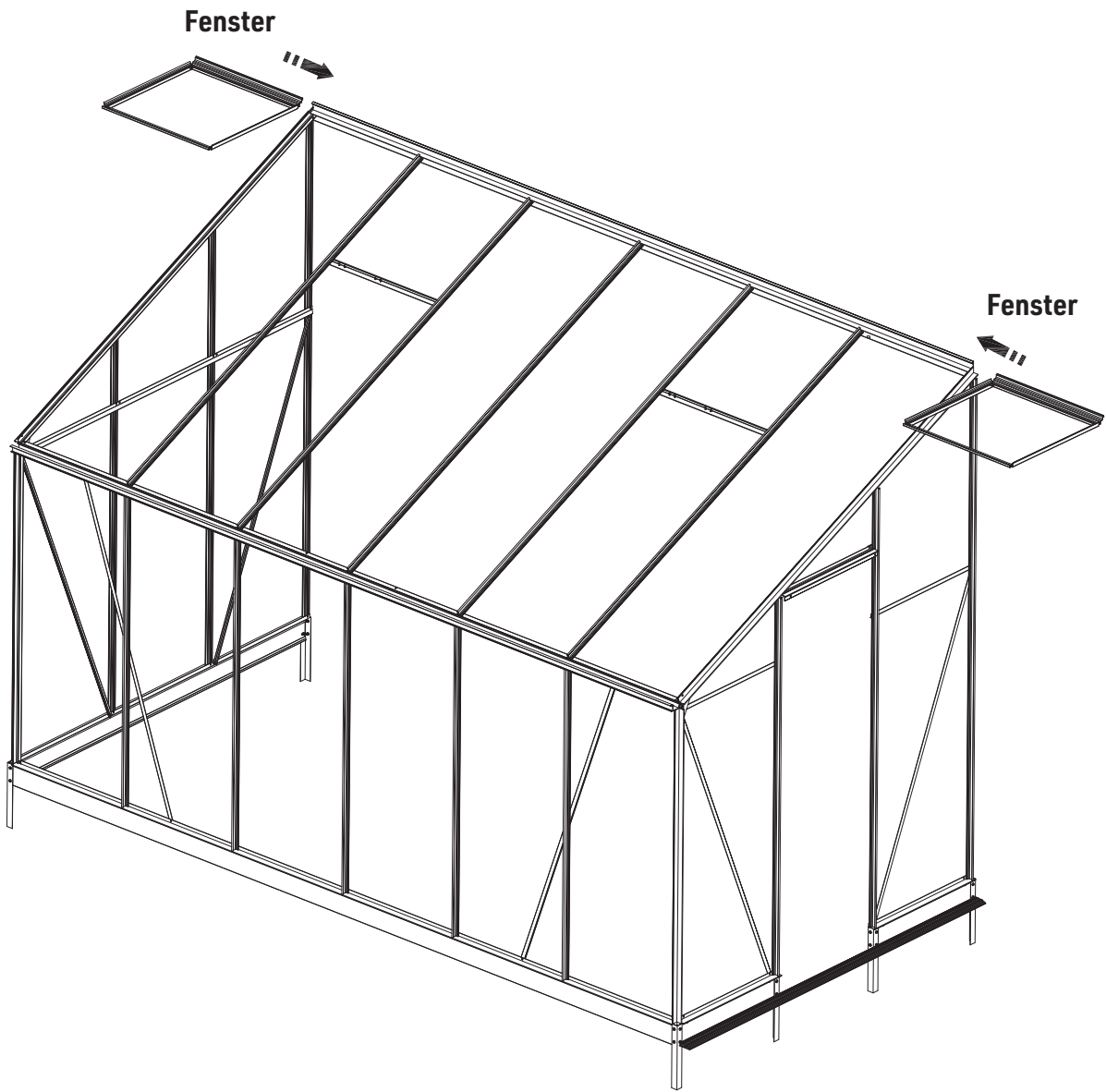

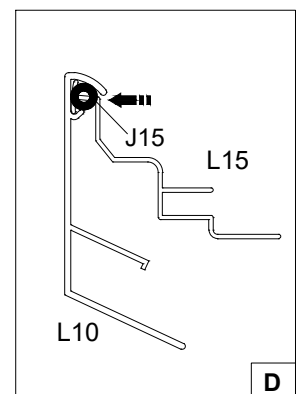
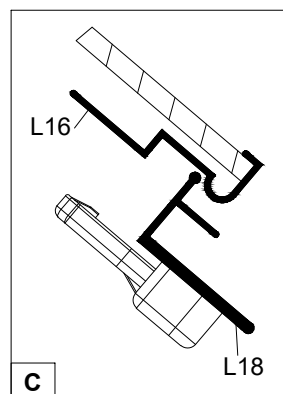
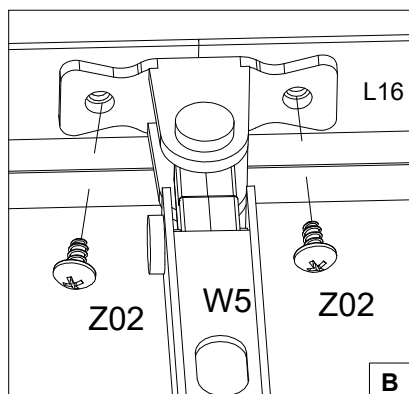
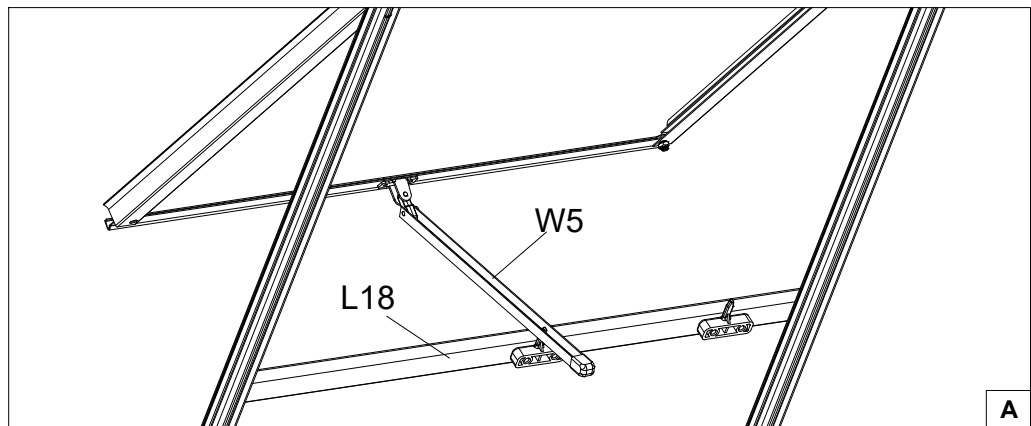
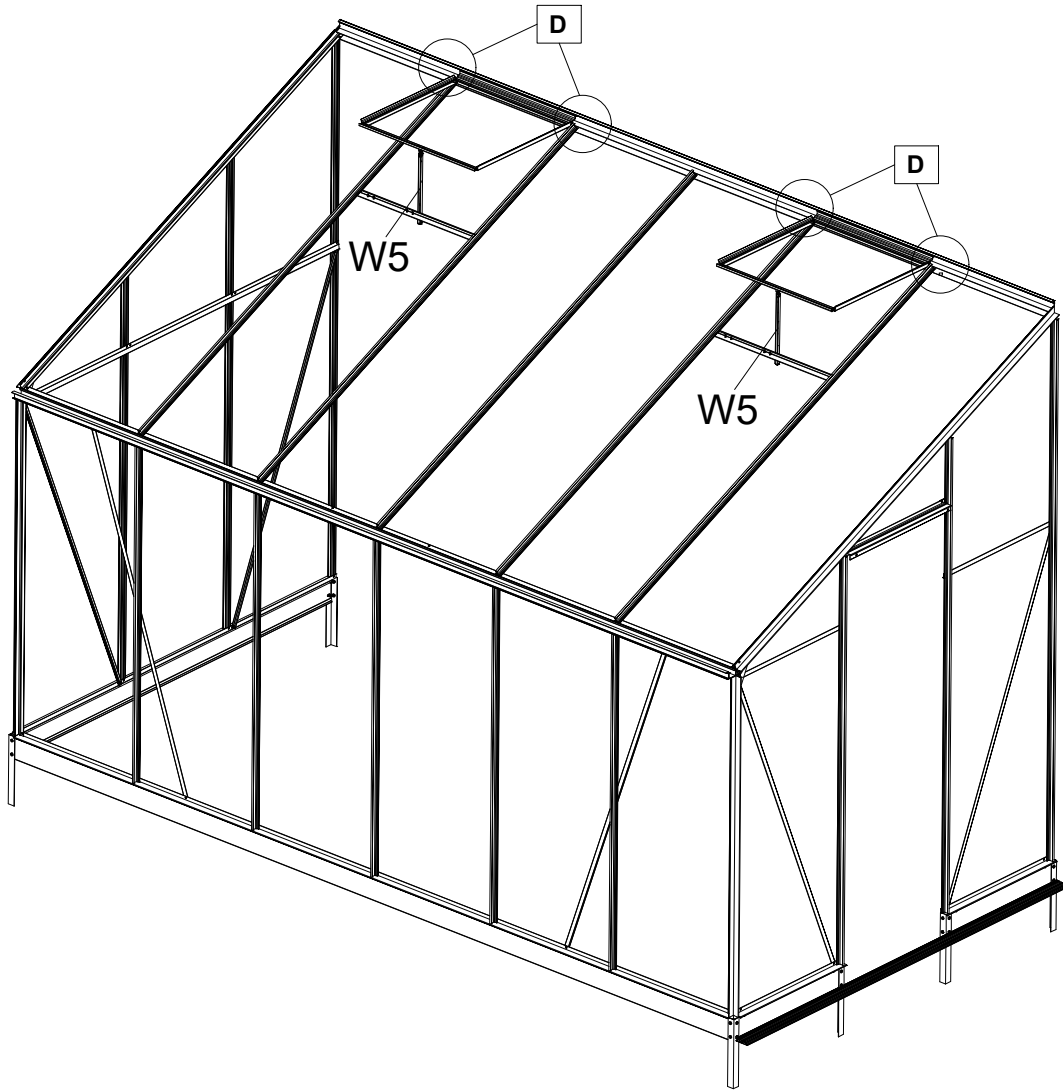

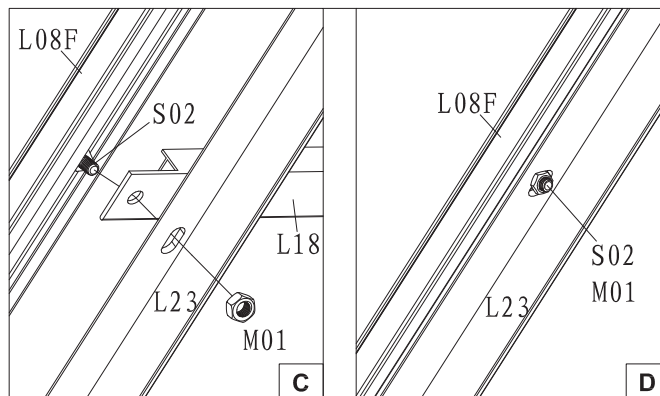
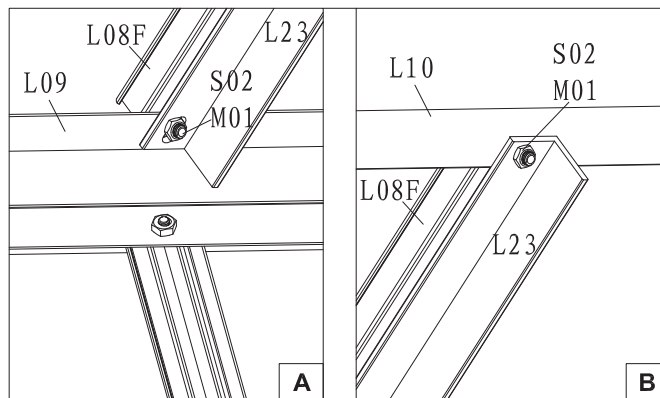
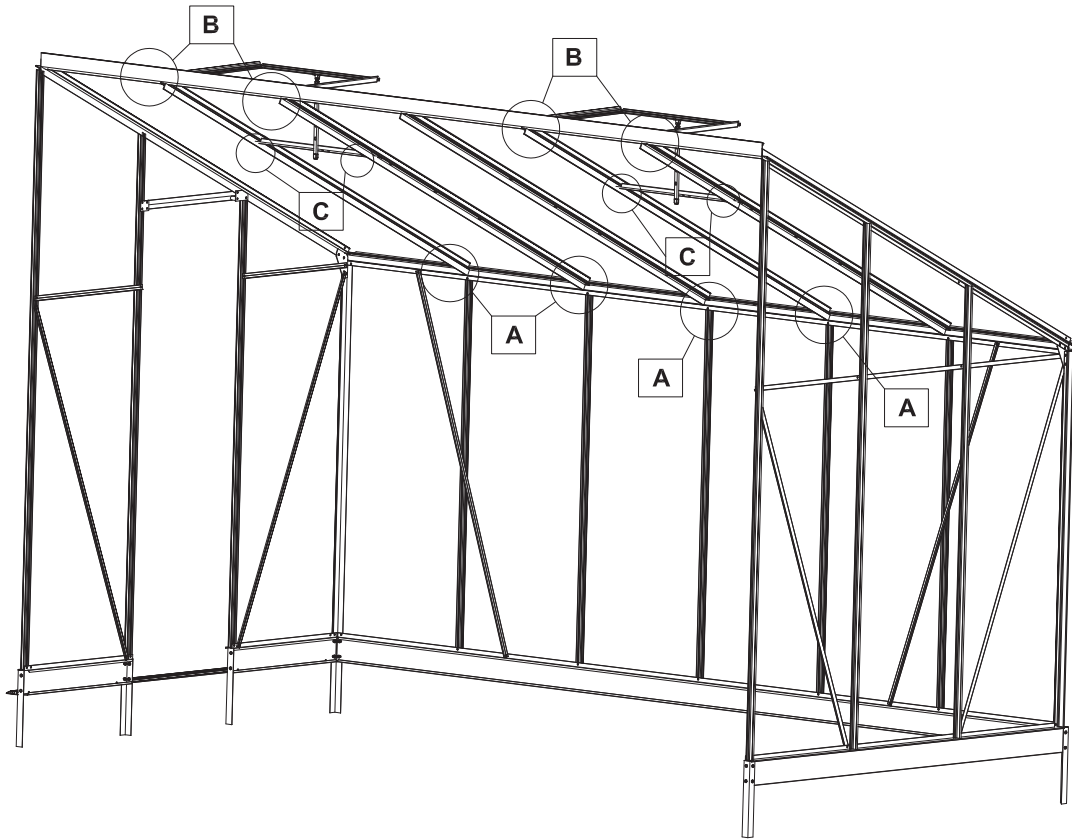

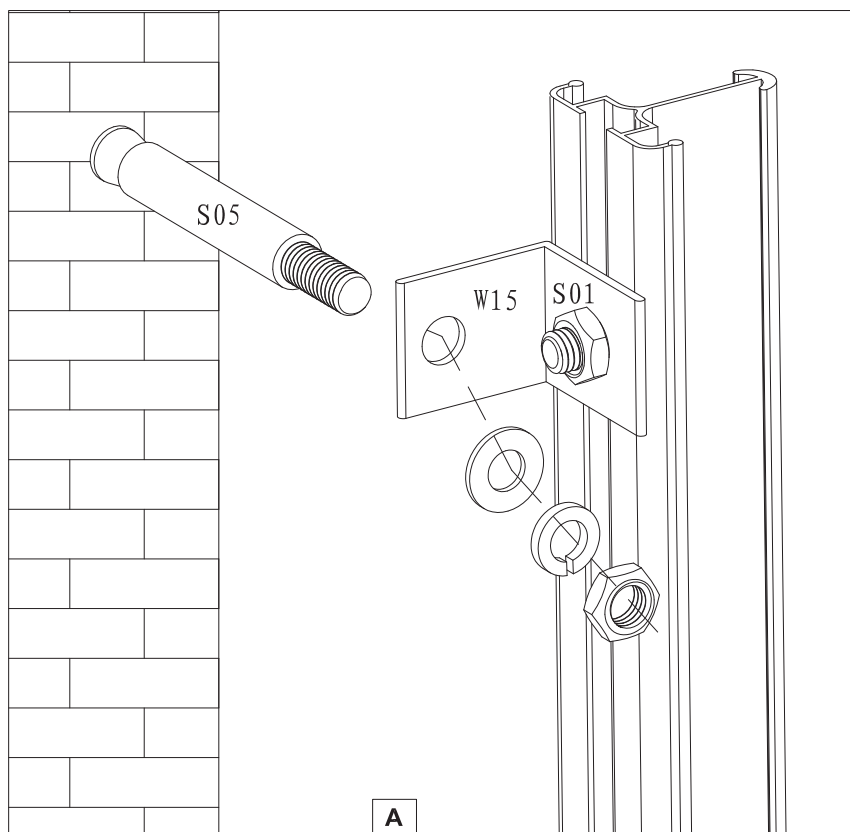
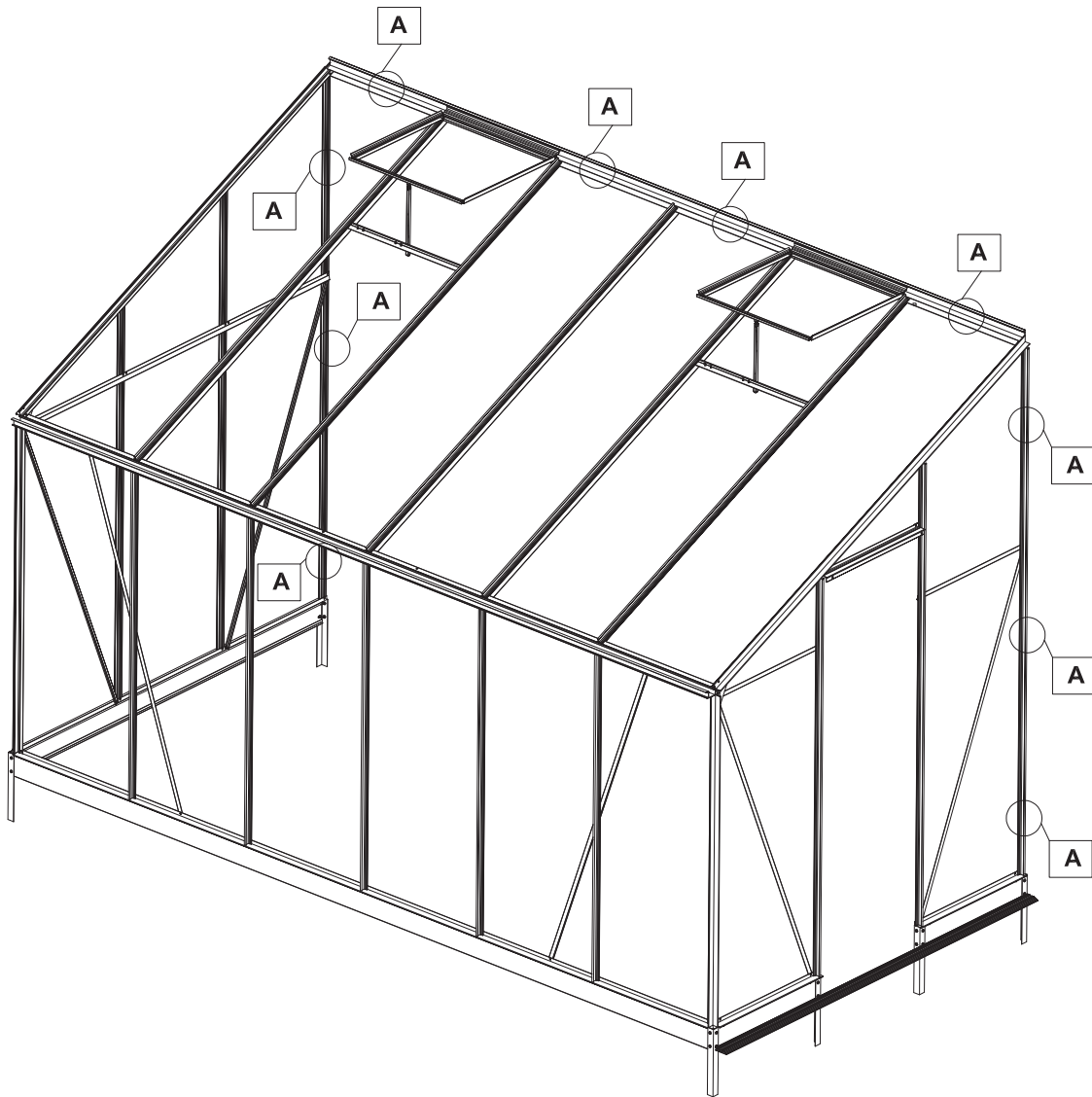

Anbringung der J19-Gummidichtung

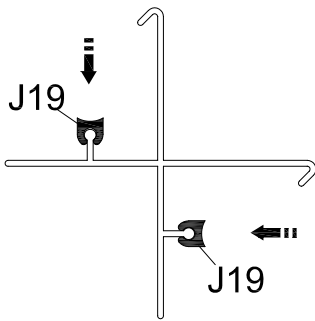

L01

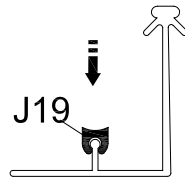

L03

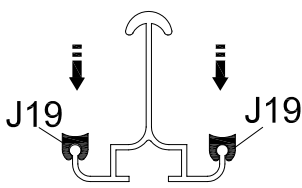

L08

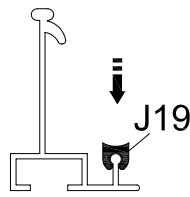

L11

Einsetzen der Scheiben

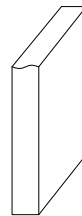
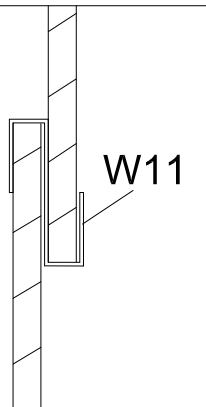
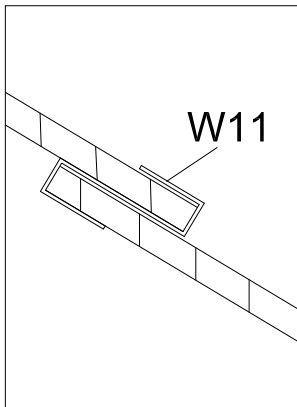
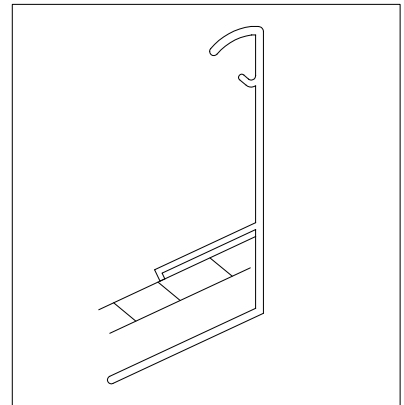
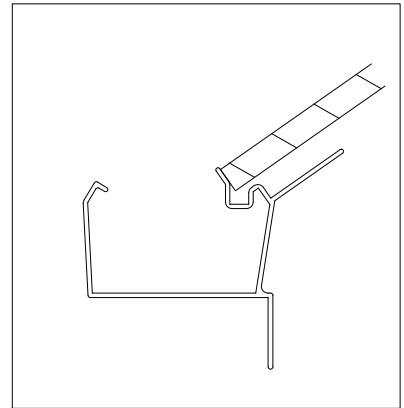

Achten Sie darauf, sich bei der Handhabung und Anpassung der Scheiben nicht zu verletzen

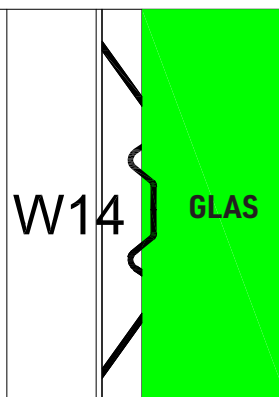
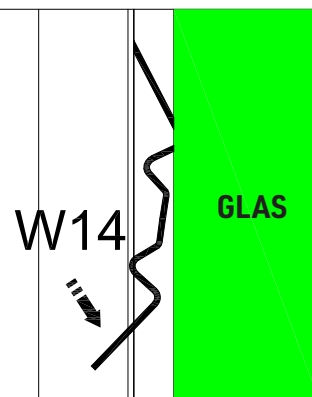
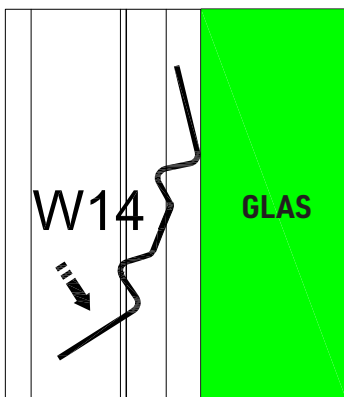
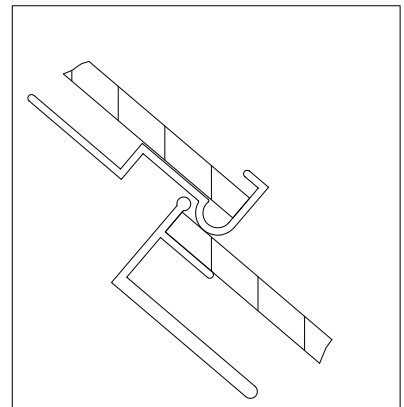



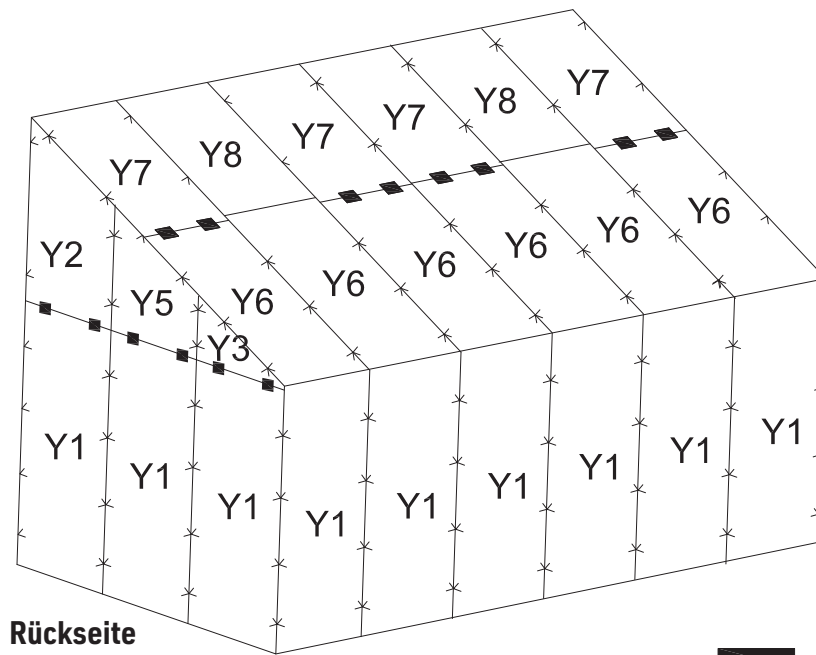
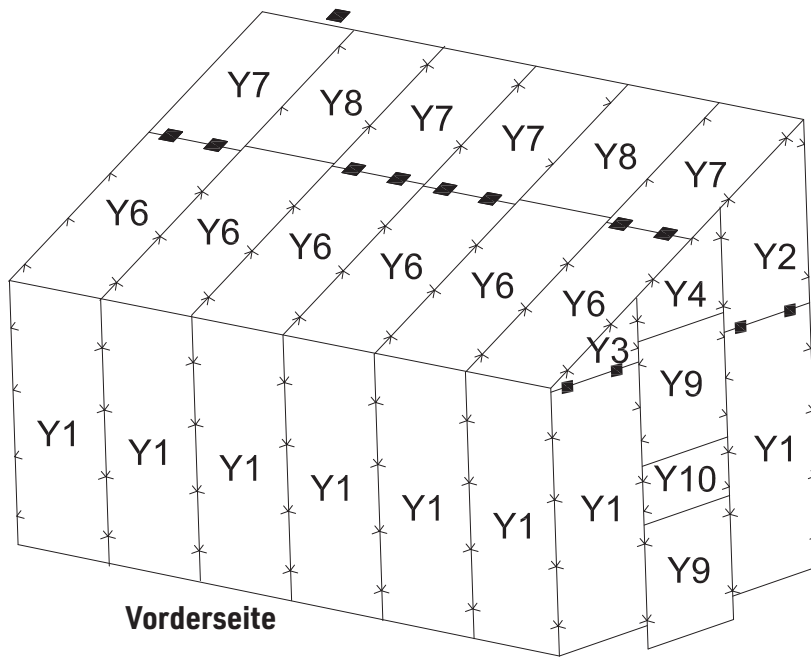







Achten Sie darauf, sich bei der Montage der W14-Klammern nicht zu verletzen



  
Haken W11 S

  
Klammern W14

Teile	#	mm	Anzahl
	Y1	610x1472	11
	Y2	610x904x619	2
	Y3	610x326x41	2
	Y4	608x292x10	1
	Y5	610x616X330	1

Teile	#	mm	Anzahl
	Y6	610x1338	6
	Y7	610x738	4
	Y8	602x726	2
	Y9	629x609	2
	Y10	629x395	1

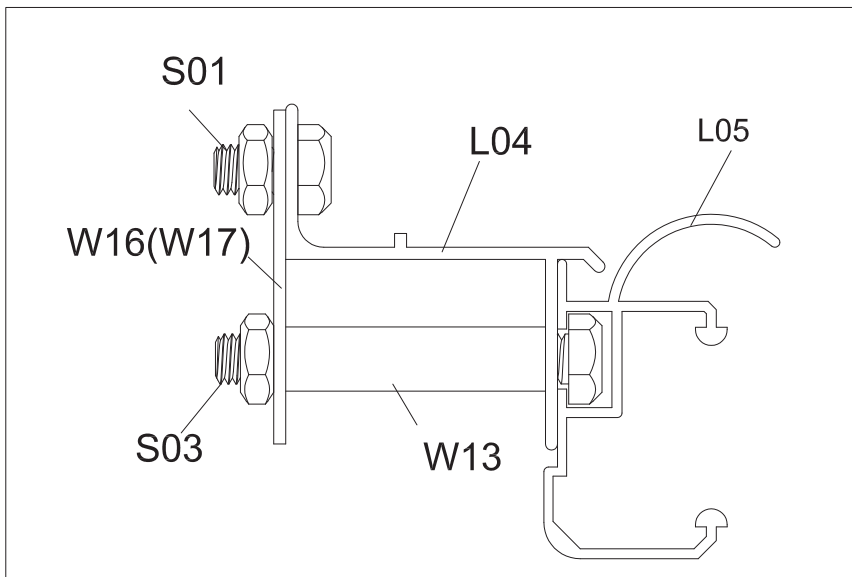
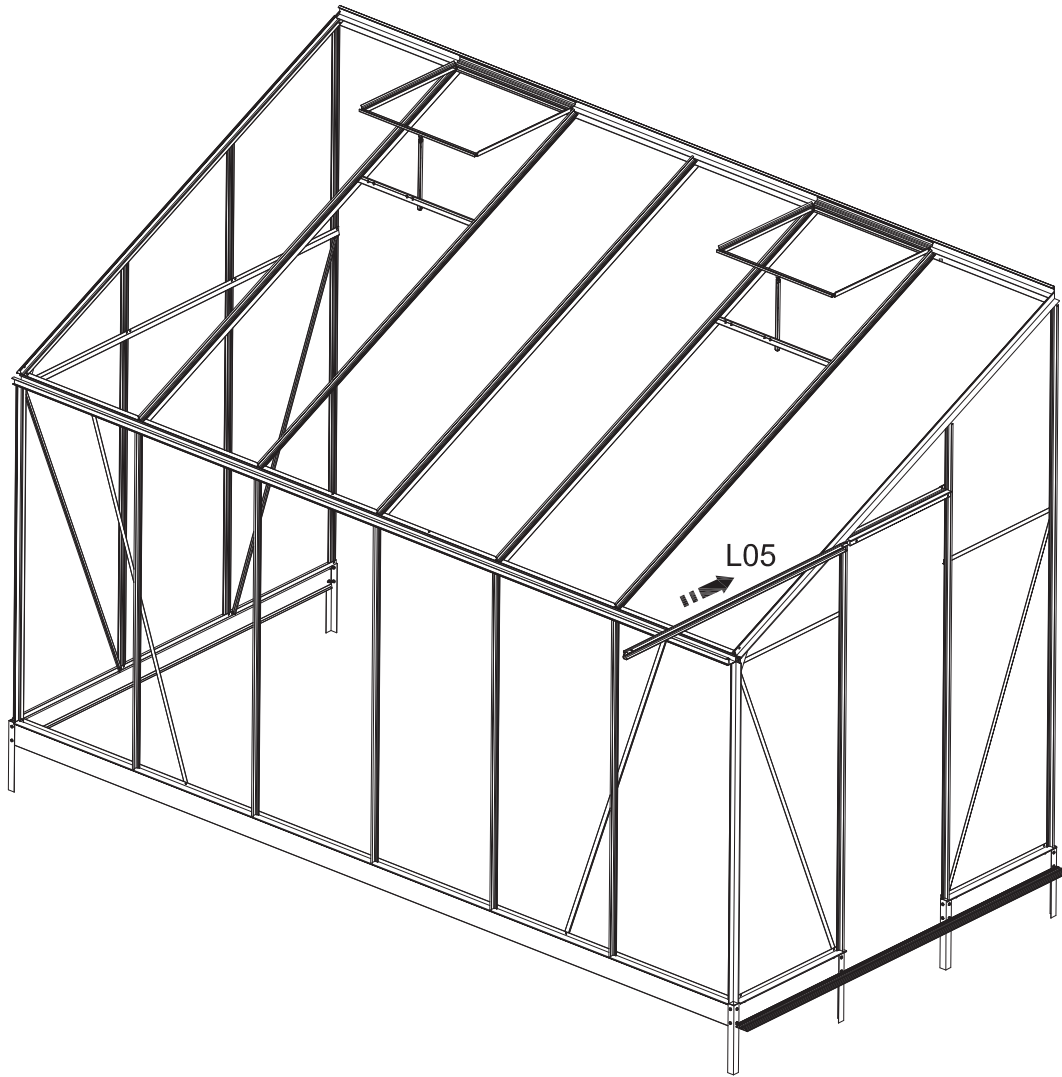

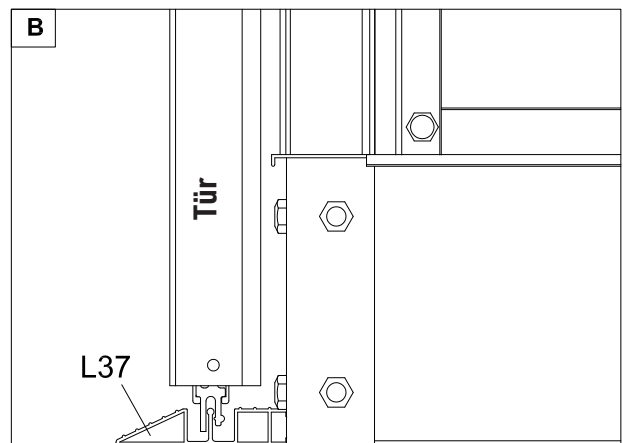
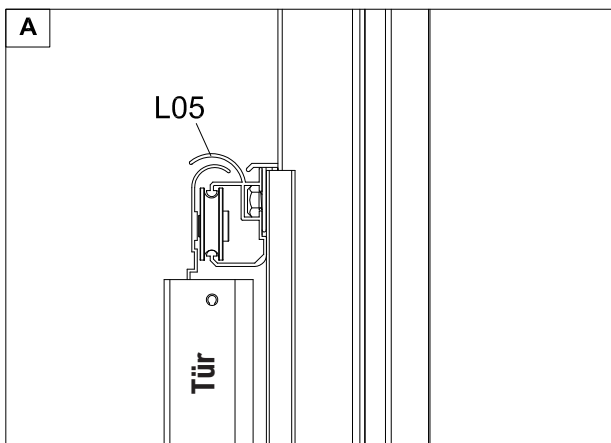
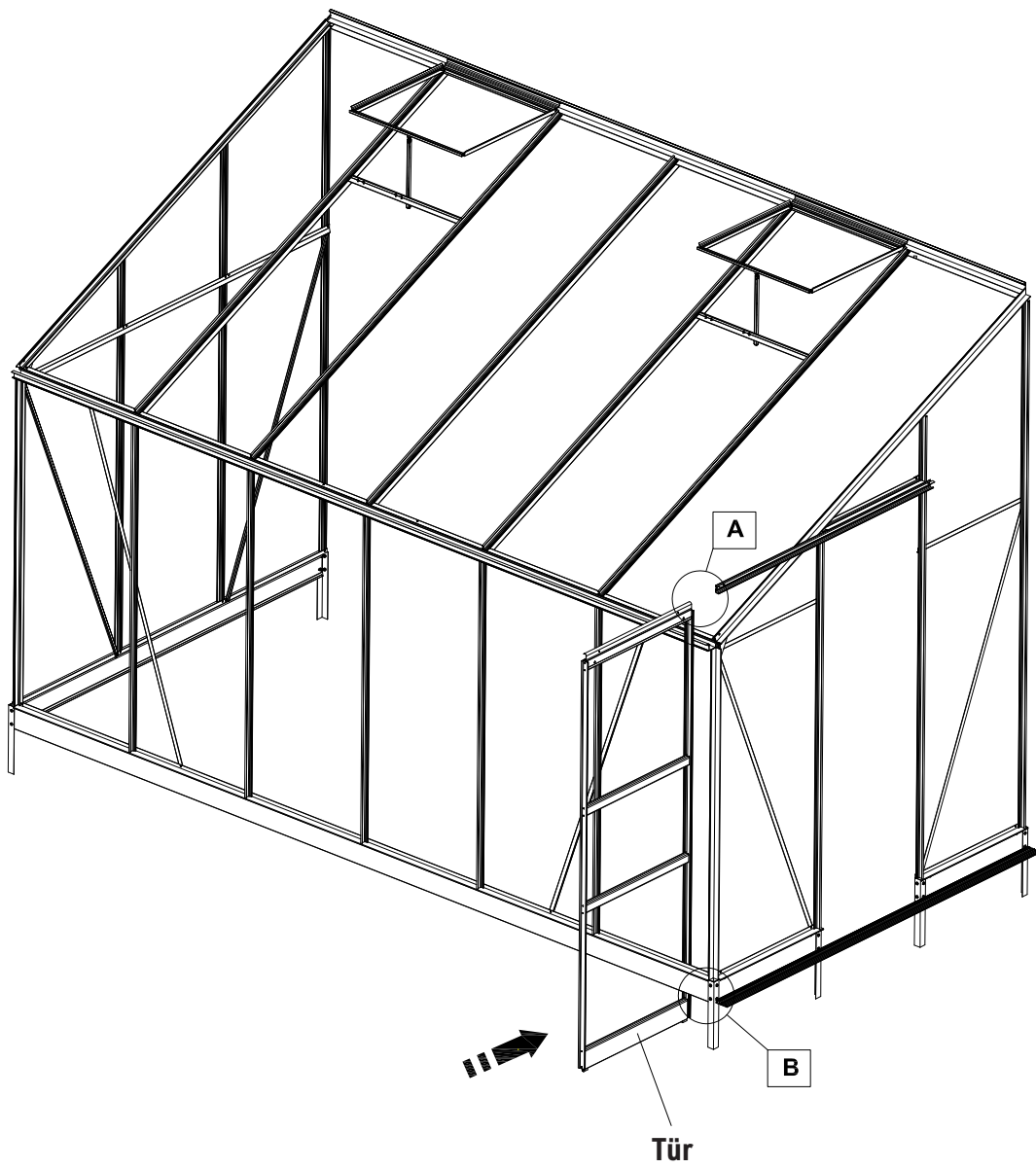

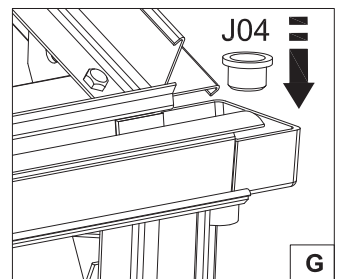
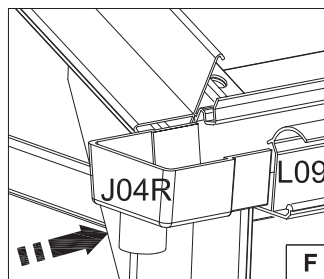
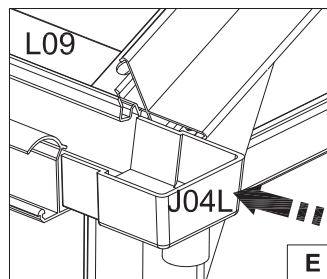
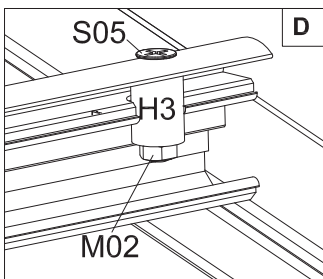
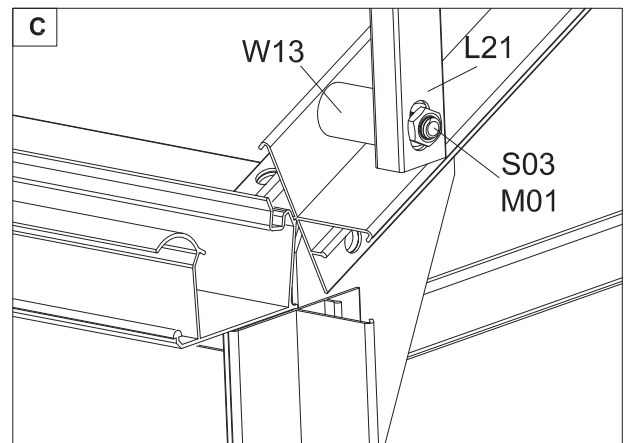
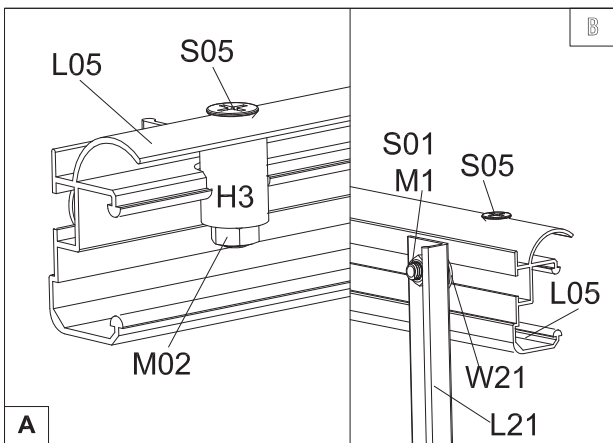
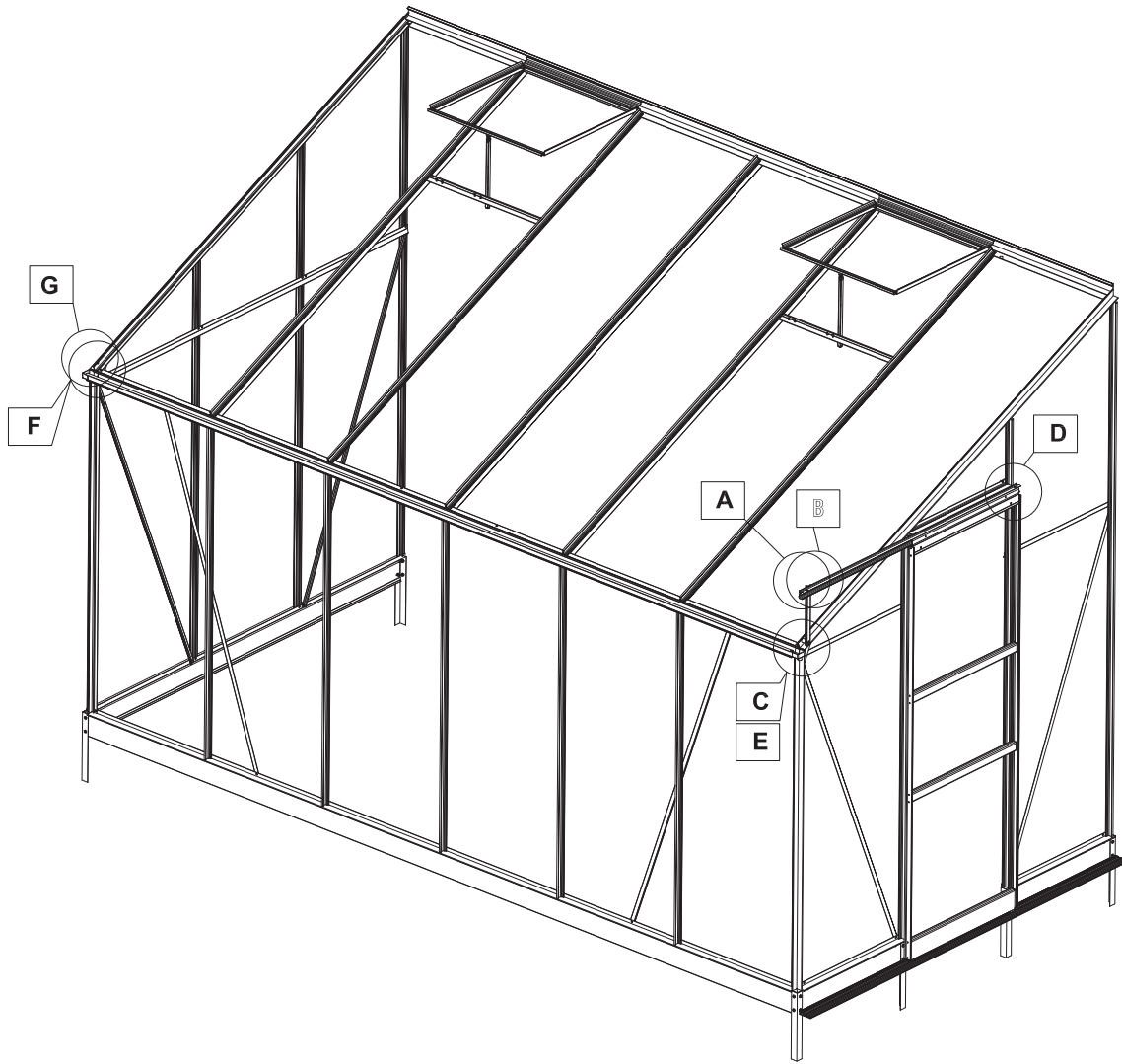

Querido cliente

Felicitaciones por la compra de su nuevo invernadero de jardín. Lea atentamente las siguientes instrucciones antes de proceder con el montaje.

**Advertencia: antes de iniciar la construcción de su invernadero, tómese el tiempo necesario para identificar todos los posibles peligros como cables o tuberías enterrados o aéreos, etc.**



### Ubicación de la instalación

- ☑ Un lugar soleado, abierto, orientado al norte, protegido de los fuertes vientos, es el mejor lugar para aprovechar al máximo su invernadero.
- ☑ Su invernadero debe colocarse en un suelo plano y nivelado. Hay muchas opciones de bases que pueden adaptarse a sus necesidades. Los invernaderos vienen con una base para satisfacer la mayoría de las necesidades de montaje.
- ☑ El acceso al agua y la electricidad debe considerarse en una etapa temprana y antes de colocar una base sólida.
- ☑ Es recomendable tener suficiente acceso alrededor de su nuevo invernadero durante su instalación y luego para su mantenimiento.

### Implantación



- ☑ Ensamble el marco de aluminio (sin el acristalamiento) y colóquelo en el lugar de instalación, para poder cavar sus agujeros para los cimientos. Esto le permitirá ubicar y marcar la posición exacta de los orificios de los postes para el anclaje.
- ☑ Una vez que haya marcado sus posiciones de anclaje, mueva el marco del invernadero para permitir que se cavén los agujeros.
- ☑ Se recomienda una profundidad mínima de 60 cm y un diámetro de 20 cm. Una vez que las estacas de anclaje estén unidas a la base y los soportes, puede levantar el invernadero sobre los agujeros y bajarlo al nivel del suelo.
- ☑ Una vez que esté satisfecho con la posición final y se haya asegurado de que el marco esté cuadrado, nivelado y plano, se puede verter hormigón en los orificios de anclaje.







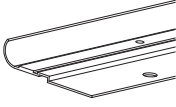
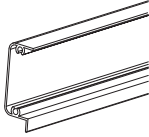
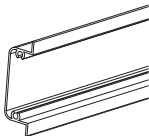
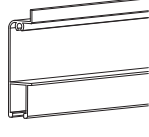
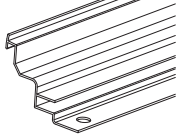
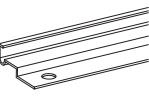
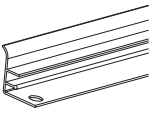
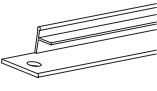
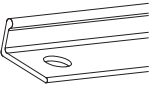
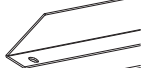



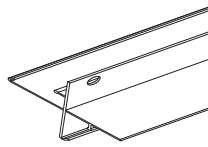
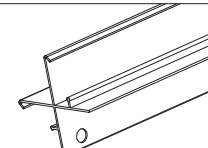
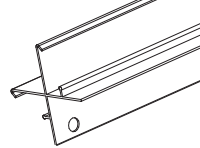
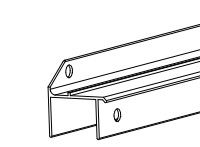
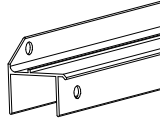
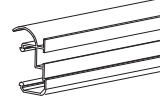
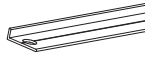



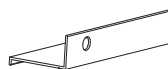

### Fijación sobre una base sólida

- ☑ Utilice el plano de la base que se proporciona con el manual de instrucciones como guía para construir su base sólida, ya sea de madera, ladrillo, hormigón,
- ☑ Los sujetadores se encuentran en el interior y aproximadamente a 55 mm de la base de aluminio de 43 mm.





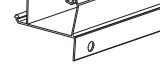
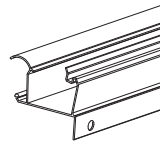
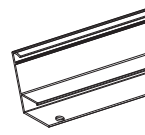
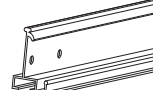





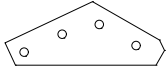

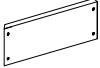

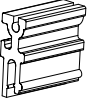
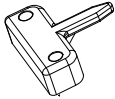

### Acristalamiento

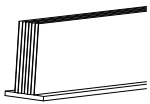
- ☑ Una vez finalizada la instalación del marco de aluminio, se puede comenzar con la del acristalamiento.
- ☑ Aunque todos los vidrios son vidrios de seguridad templados, deben considerarse peligrosos y manipularse con cuidado.
- ☑ Asegúrese de que el marco esté libre de escombros antes de comenzar. Cuidado con el viento en todo momento.
- ☑ Si está colocando paneles junto al invernadero durante la construcción, se recomienda una posición inclinada.
- ☑ Comience con los paneles del techo y trabaje de punta a punta.
- ☑ Para insertar los paneles del techo, apóyese contra las canaletas y deslícelas entre las barras de refuerzo hasta que lleguen a la cumbrera y encuentren su lugar.
- ☑ Deslice los paneles de la pared inclinándolos entre las barras verticales de aluminio, empújelos hacia arriba y hacia el rebaje ubicado debajo de la canaleta.
- ☑ Asegúrese de que la parte inferior del panel de vidrio descance correctamente sobre la parte superior de la base.
- ☑ El panel tendrá una apariencia cuadrada y vertical y estará asegurado por la ranura en la parte inferior y la ranura en la parte superior. Inserte los sellos de goma presionando con el pulgar y el índice para guiarlo.
- ☑ Todas las gomas se hacen más largas de lo necesario y deben cortarse cuando se ajusten.
- ☑ Si la extrusión de caucho parece seca, use agua con jabón para facilitar la instalación en la barra de acristalamiento.
- ☑ Los sellos deben verse planos y rectos cuando estén terminados.
- ☑ Deje las gomas durante una o dos horas antes de cortarlas a la longitud requerida, ya que pueden estirarse y luego retraerse al insertarlas.
- ☑ No corte las gomas hasta que las haya insertado todas.

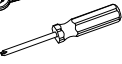
Pieza	Ref	mm	Cant.
	L12	640	1
	L13A	640	1
	L13B	640	2
	L38	640	1
	L15	602	2
	L16	602	2
	L17	700	4
	L18	638	2
	L21	259	1
	L22	1865	1
	L23	2042	5
	L37	1842	1

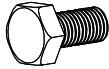
Pieza	Ref	mm	Cant.
	L01A	2073	1
	L01B	2073	1
	L01C	1474	1
	L01D	1474	1
	L04	592	1
	L05	1300	1
	L06A	1547	4
	L06B	620	1
	L06C	640	1
	L06D	1558	2
	L07A	1869	1
	L07B	3706	1
	L07C	626	1
	L07D	646	1
	L08A	2358	1
	L08B	2358	1
	L08C	1780	1
	L08D	1780	1
	L08E	1474	5
	L08F	2046	5
	L08G	2069	1
	L08H	2069	1
	L09	3708	1
	L10	3708	1
	L11A	1816	1
	L11B	1816	1



Pieza	Ref	mm	Cant.	Pieza	Ref	mm	Cant.
	M01	M6	113		W2		2
	M02	M5	2				
	Z01	Ø4*16	24		W5		2
	Z02	Ø4*6	4				
	H3		2		W07A	655	1
					W07B	645	1
					W07C	3758	1
					W07D	1900	1
	J04		1		W08	350	6
	J04L		1		W09		13
	J04R		1		W11		20
	J11		2		W13	Ø12*28	3
	J13		4		W14		210
	J15	Ø6.5*20	4		W15		6
	J18	1.82M	2		W21	Ø12*Ø6*1.5	2
	J19	78M	1		W16		1
	T01		1		W17		1
	T02		1		W46		2
					S01	M6*10	90
					S02	M6*16	24
					S03	M6*40	3
					S04	M6*14	5
					S05	M5*25	2
	S04				S07	M6*60	12

**Consejo importante:** no necesitará desmontar todo si olvidó poner los tornillos S01, puede reemplazarlos con tornillos S04!



## Montaje de la base

Es fundamental que la base del invernadero sea perfectamente cuadrada para que las medidas diagonales sean las mismas. El invernadero también debe estar nivelado de manera uniforme con la fachada frontal y la fachada trasera, la plomada debe ser perfecta.

Anclar el invernadero en el suelo es fundamental. Le recomendamos que utilice anclajes de mampostería si tiene una losa, en cuyo caso cortarías las patas del ancla.

Alternativamente, los anclajes se pueden hormigonar en el suelo (zapata mínima de 300 mm de diámetro y 400 mm de profundidad). A menudo es mejor hacer esto al final, si el tiempo lo permite. Asegure siempre la estructura temporalmente durante la construcción.

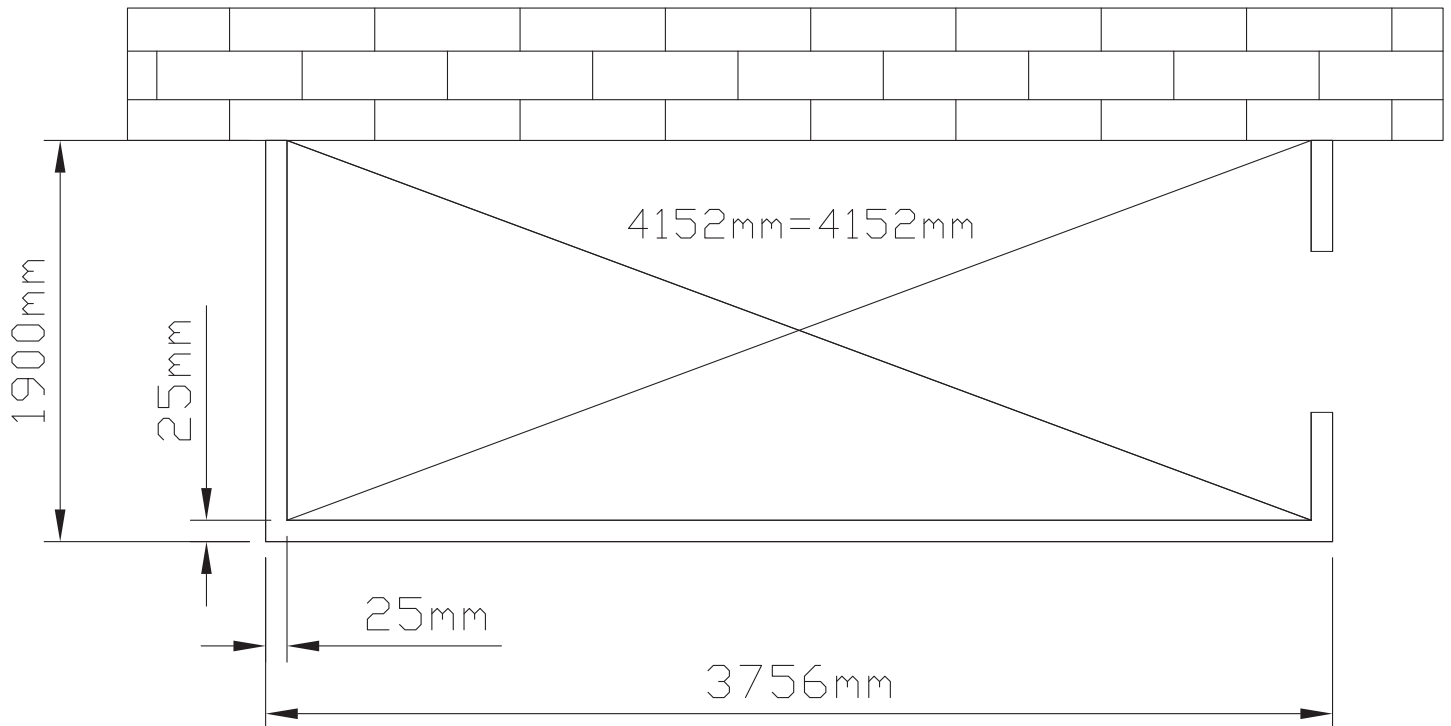
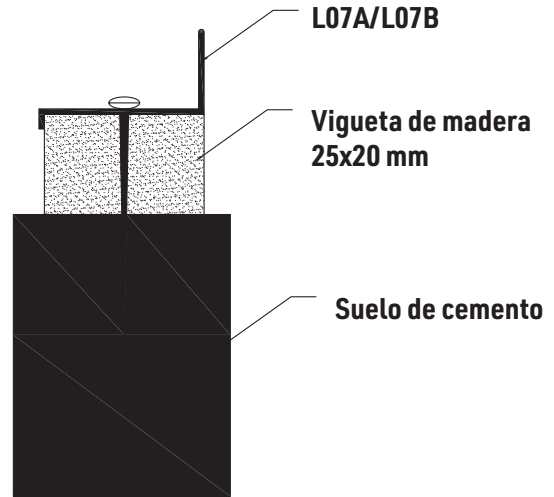

# Montaje de la base

**Nota:** Retire la película protectora de la superficie de las piezas W08 y W07 A (B / C / D) antes de montar la base

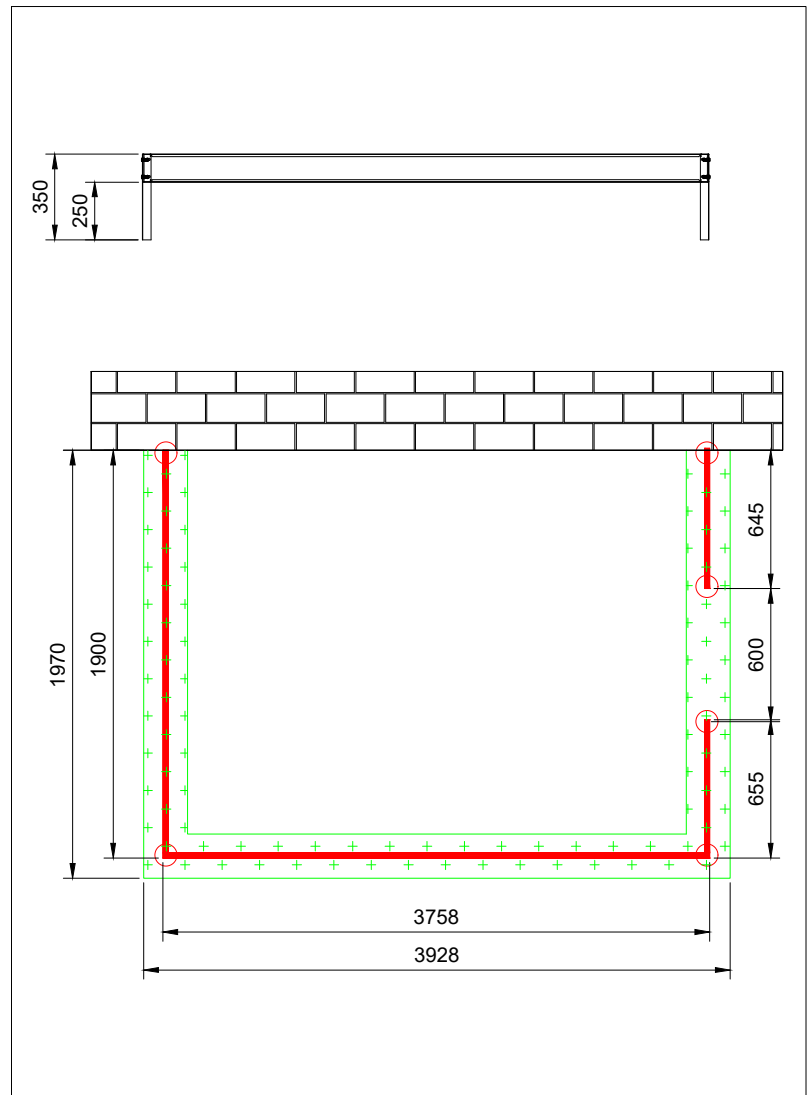
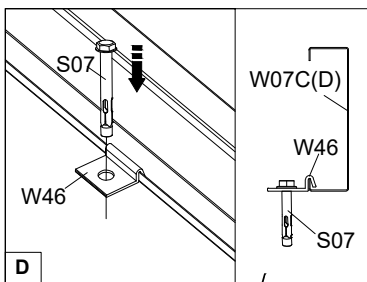
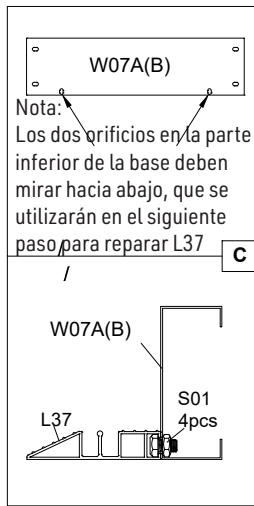
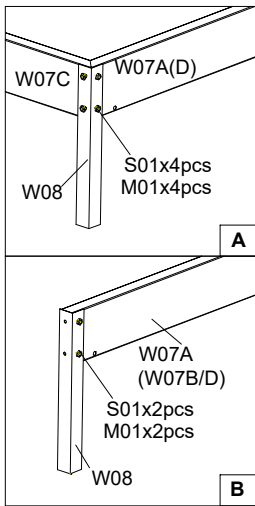
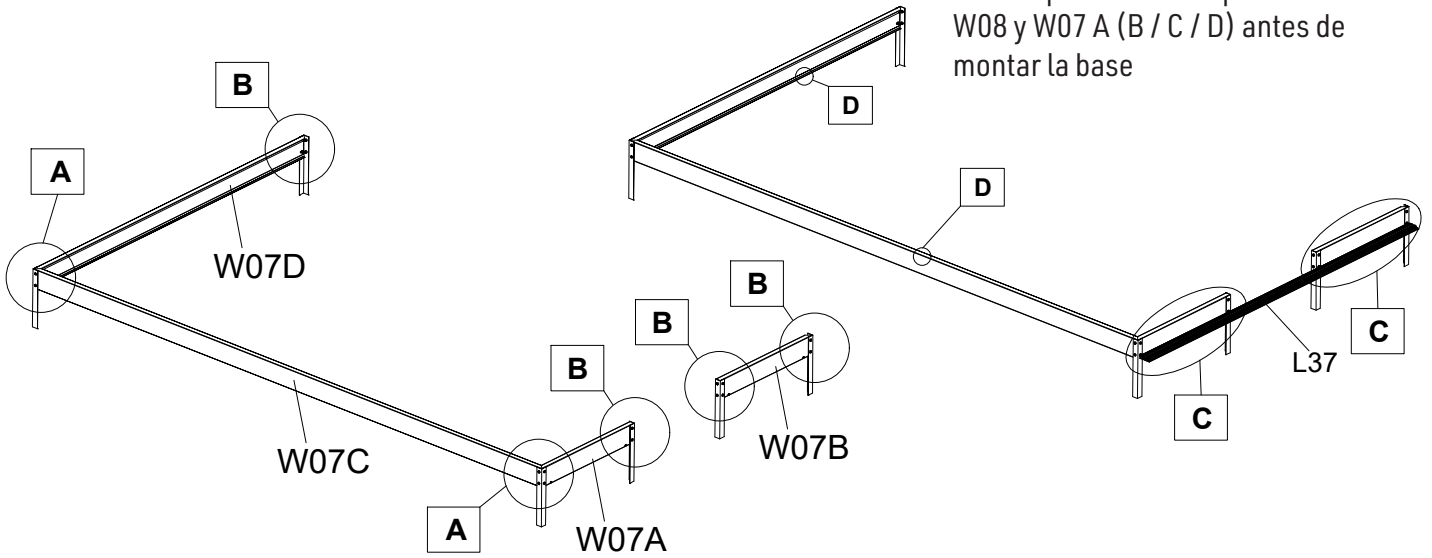

# Montaje de la puerta izquierda

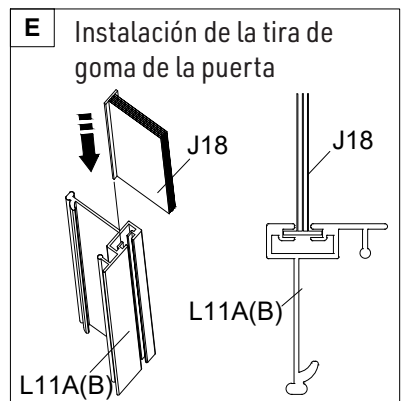
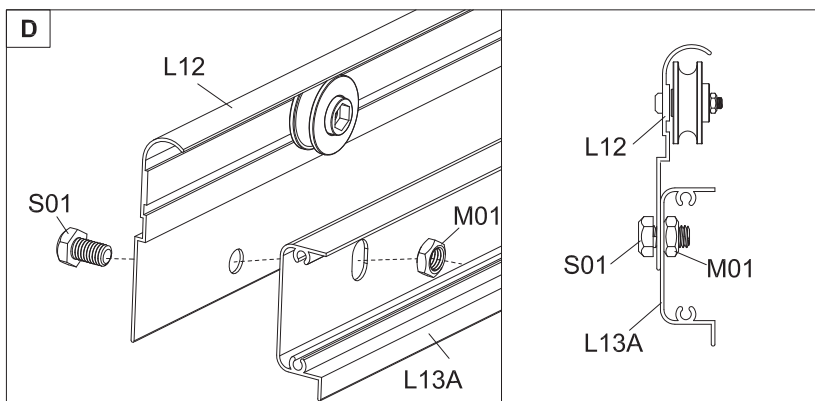
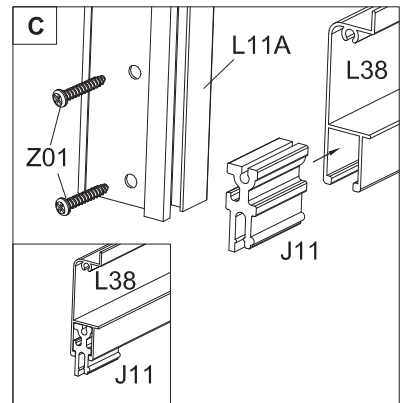
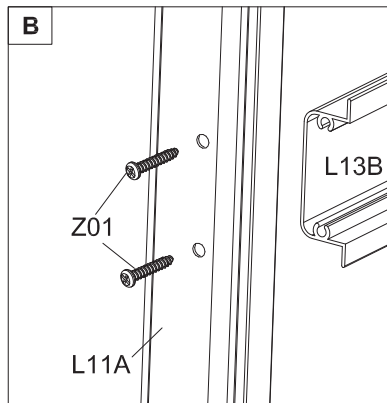
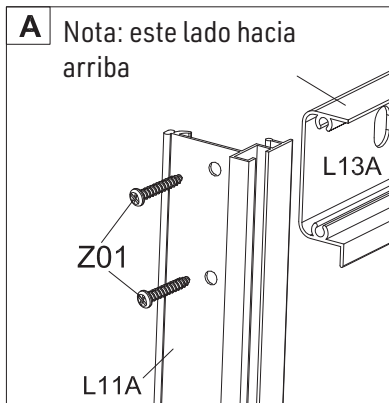
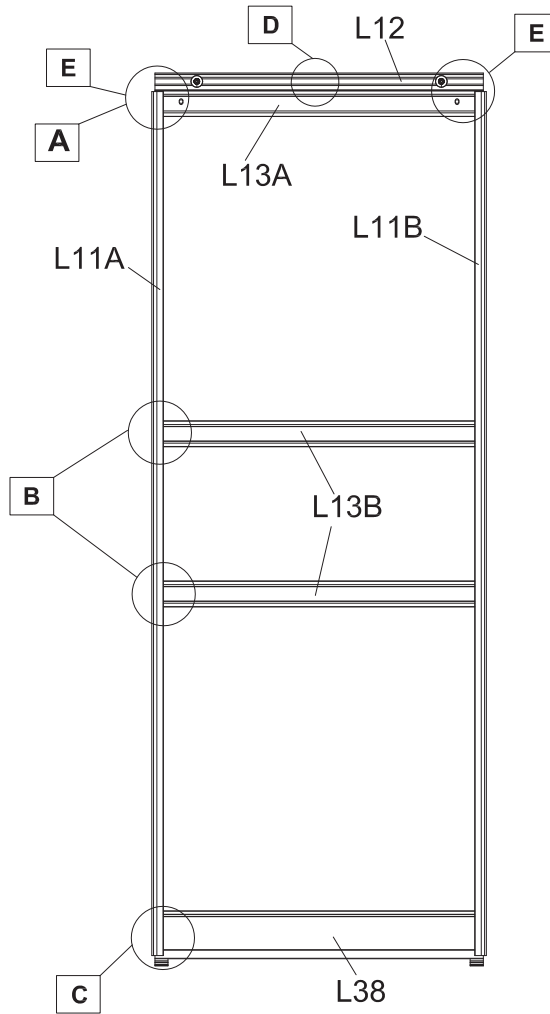

# Montaje de la ventana

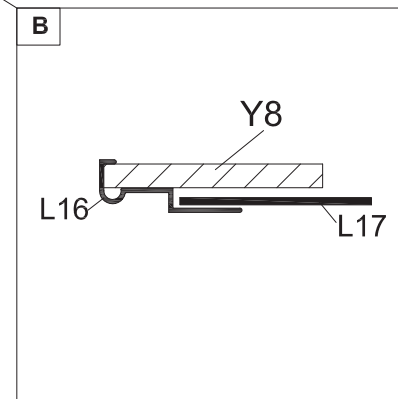
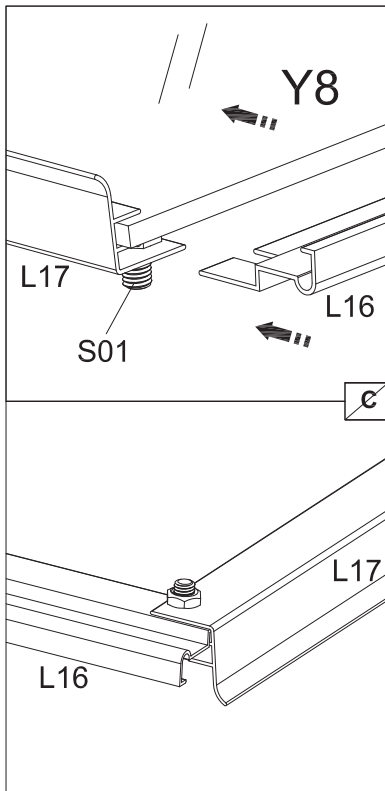
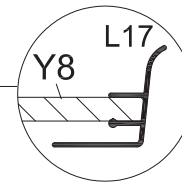
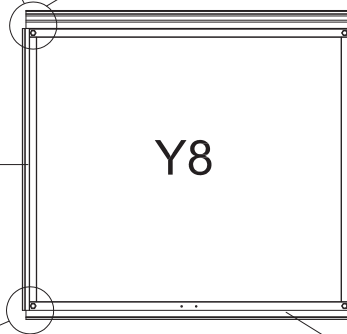
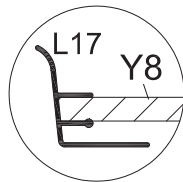
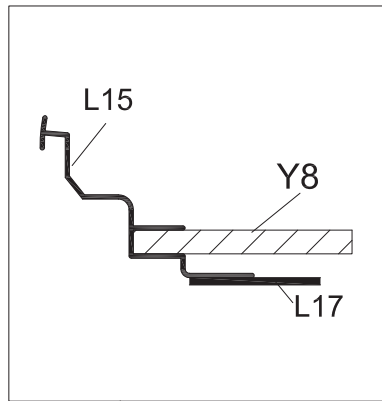
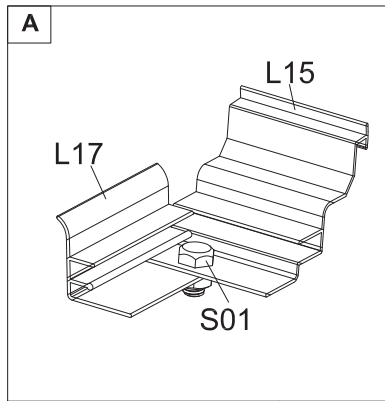

# Montaje de la rueda dentada delantera

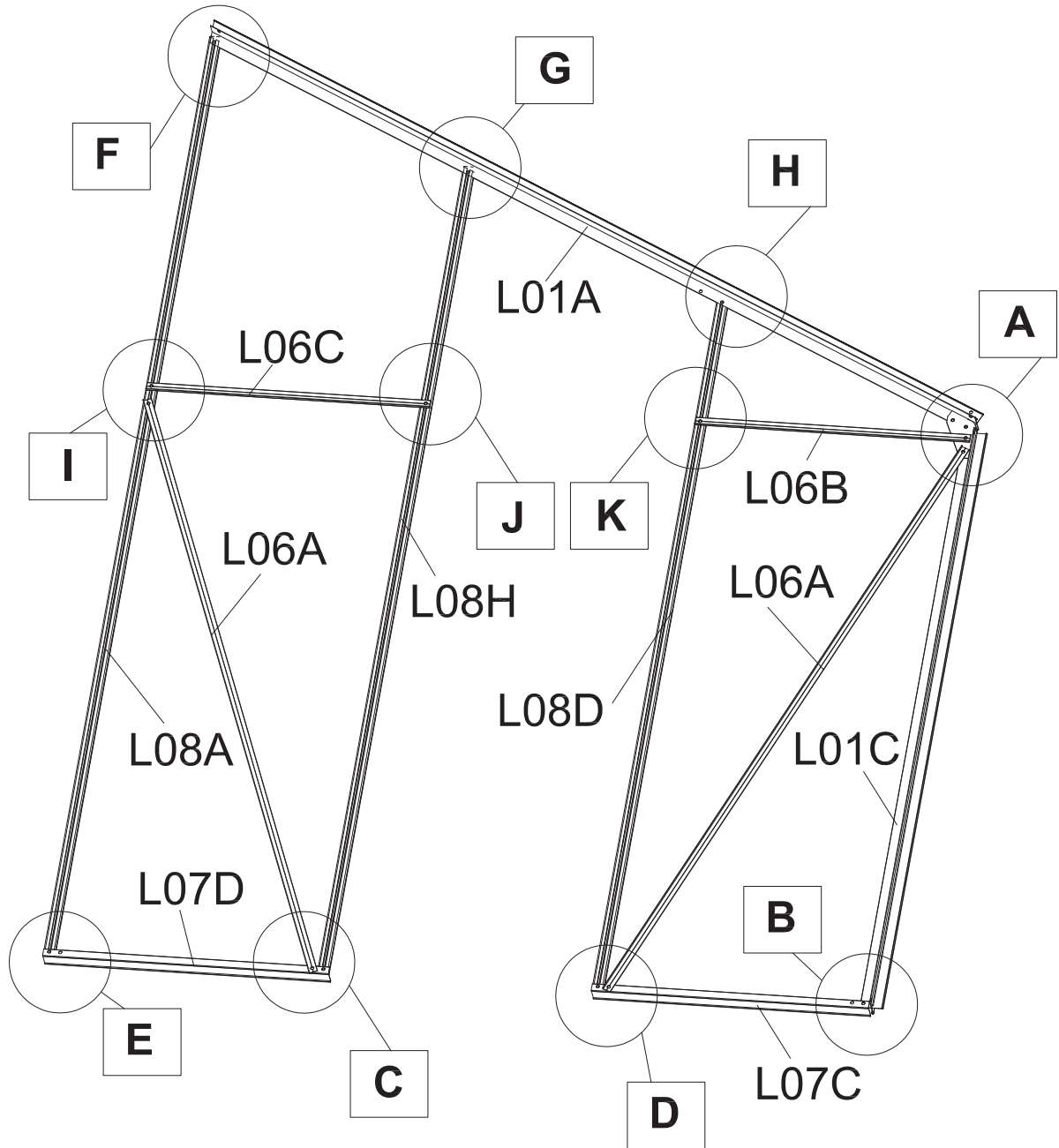

# Montaje de la rueda dentada delantera

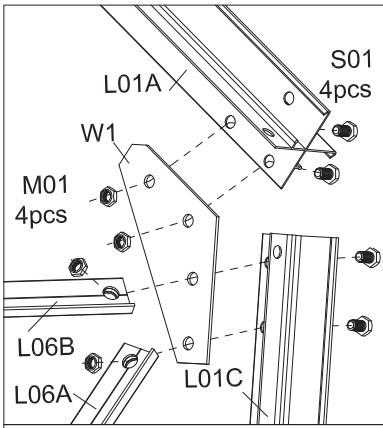

No apriete las tuercas hasta que haya ensamblado L09

**A**

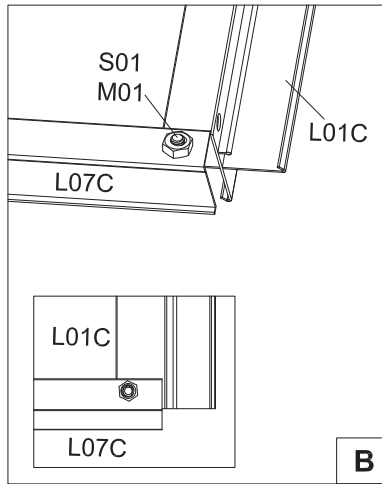

**B**

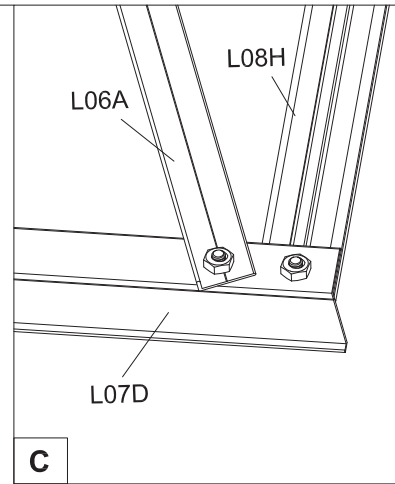

**C**

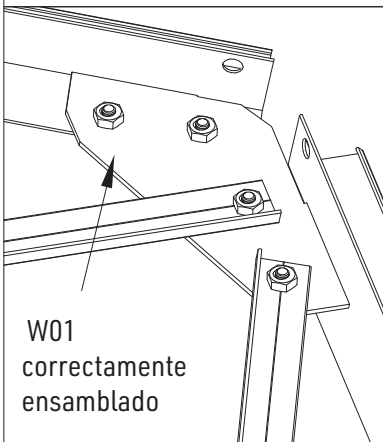

W01 correctamente ensamblado

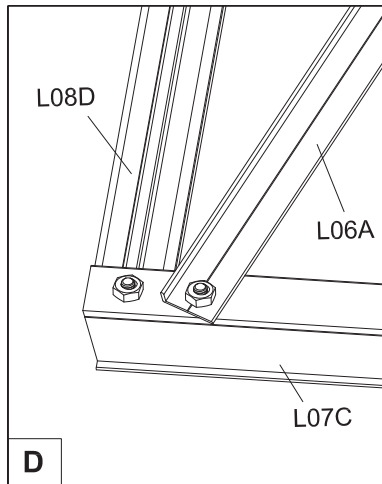

**D**

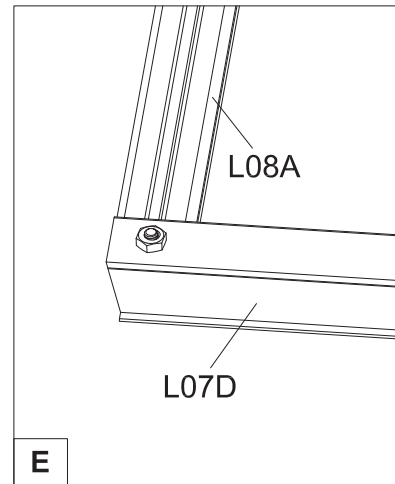

**E**

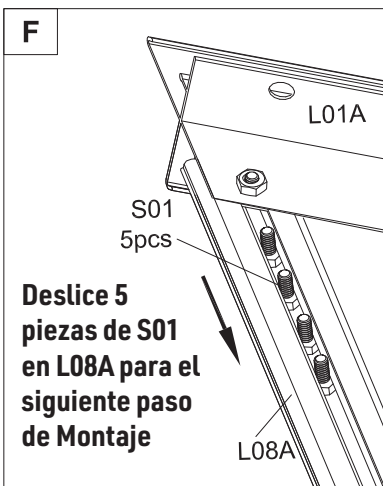

Deslice 5 piezas de S01 en L08A para el siguiente paso de Montaje

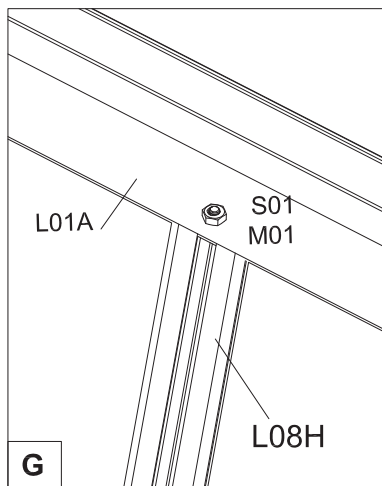

**F**

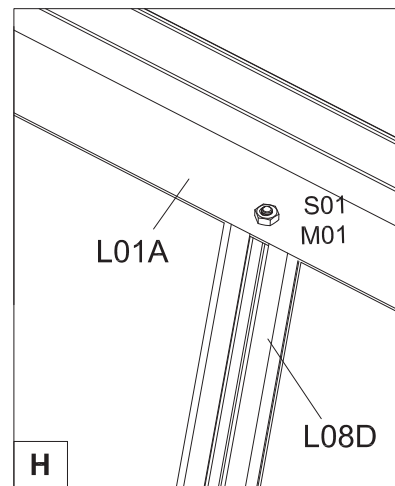

**G**

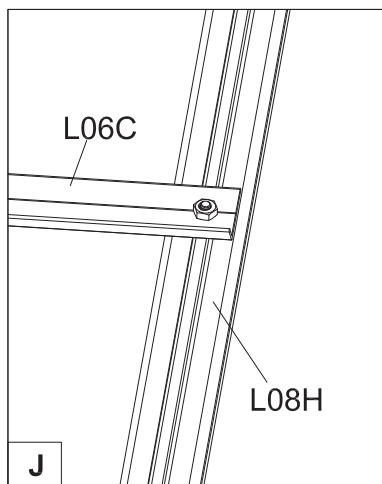
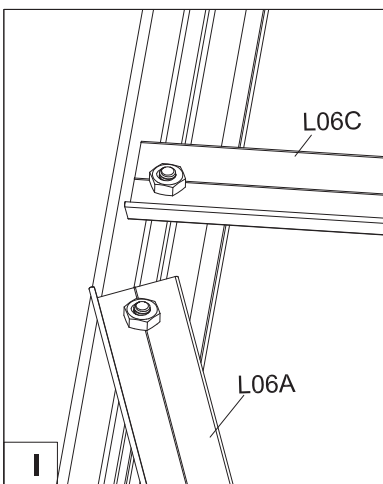

**I**

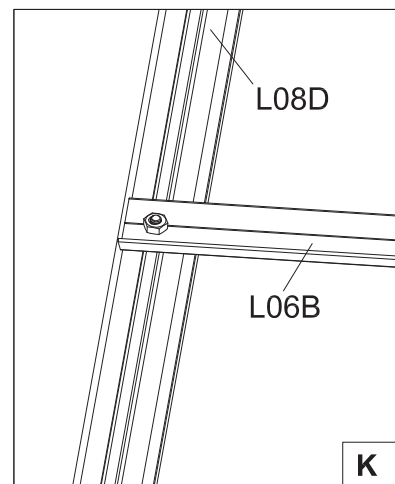

**J**

**K**



# Montaje de la rueda dentada delantera

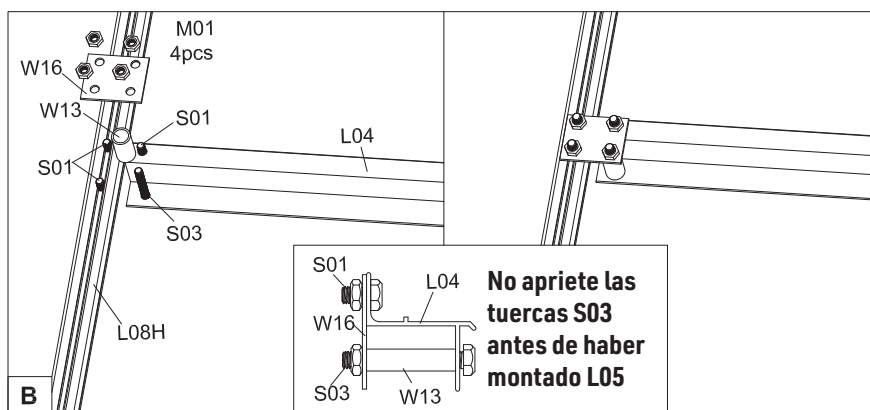
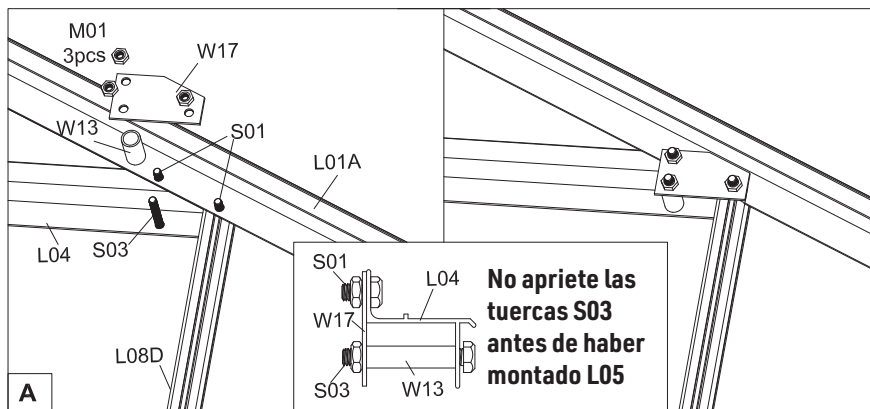
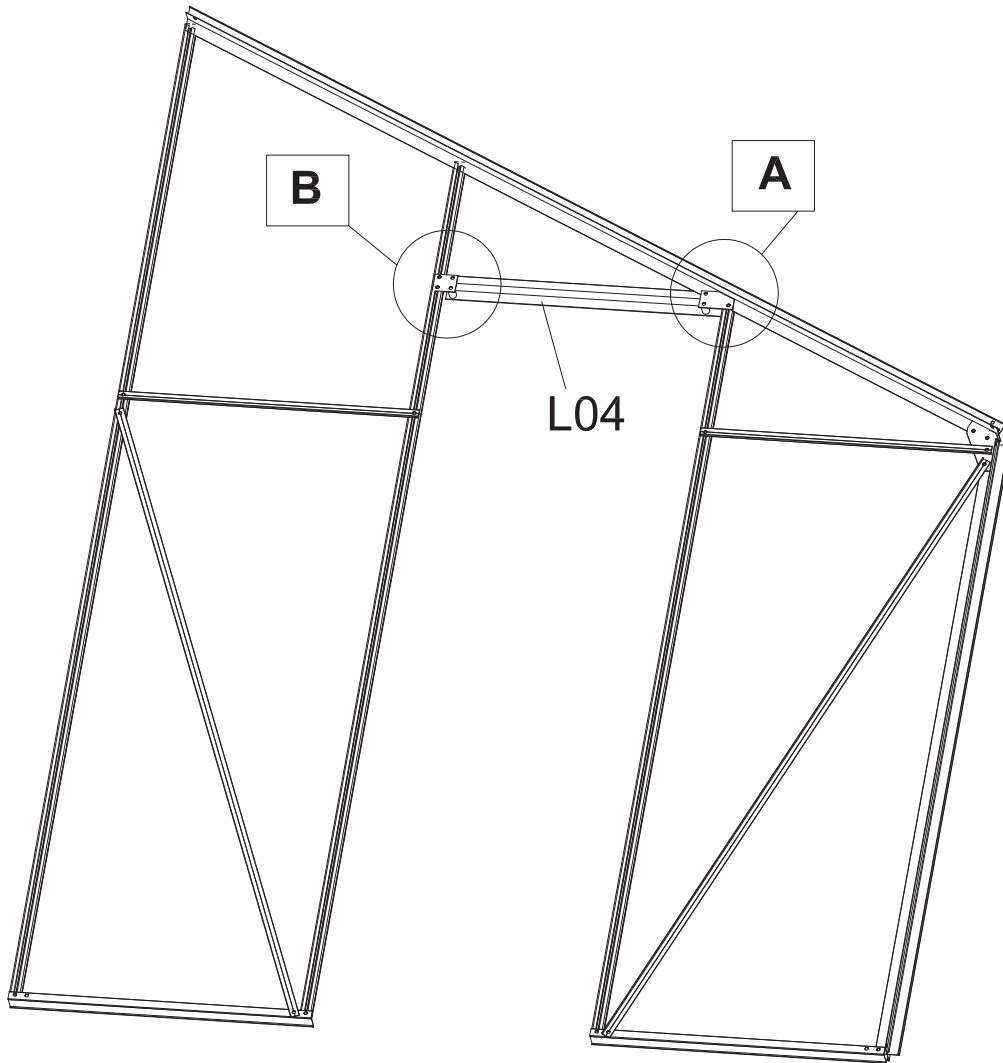

# Montaje de la rueda dentada trasera

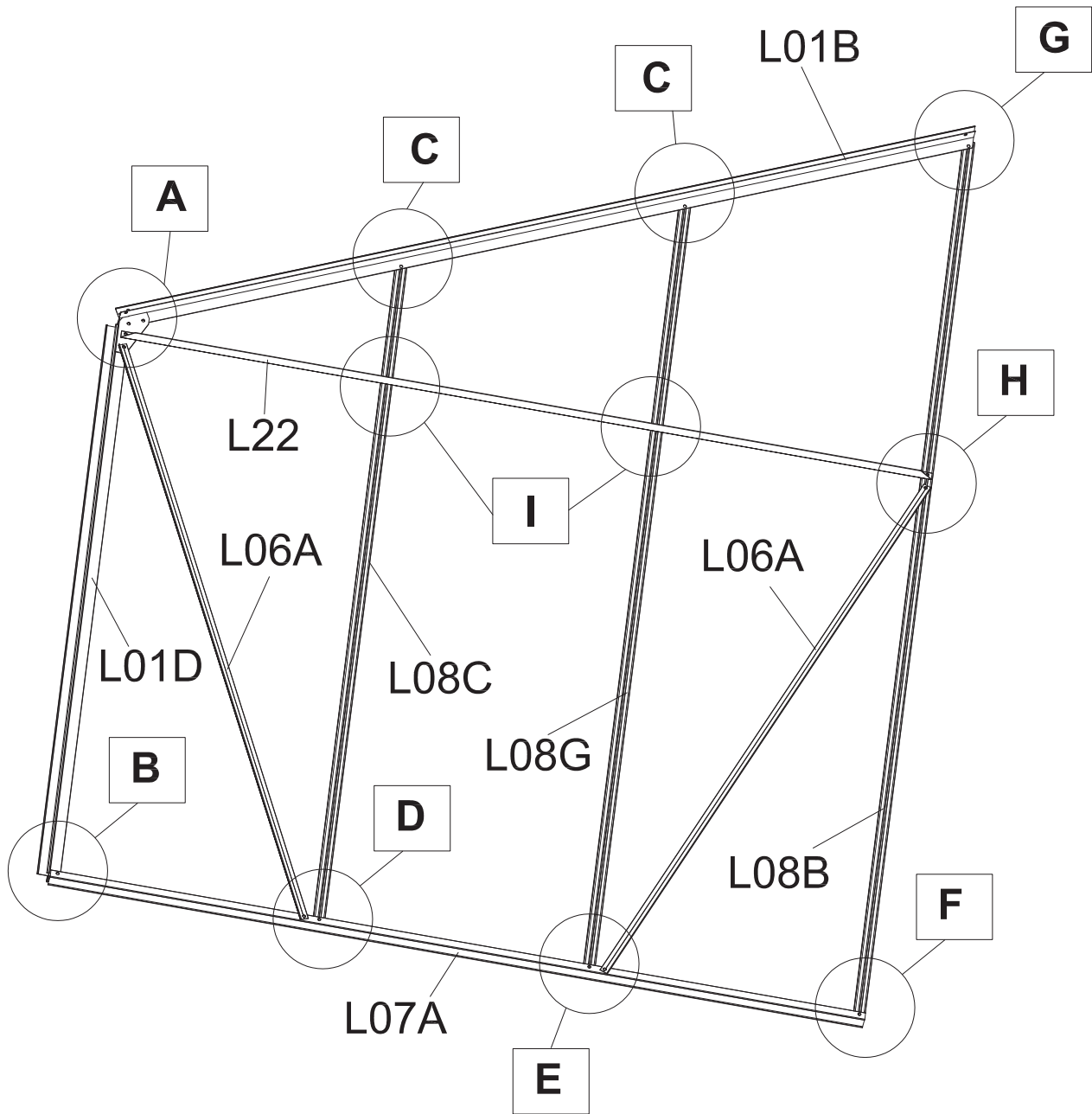

# Montaje de la rueda dentada trasera

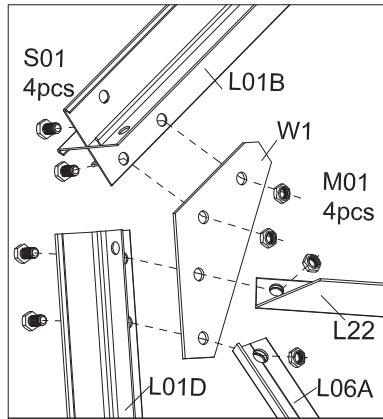

No apriete las tuercas hasta que haya ensamblado L09

**A**

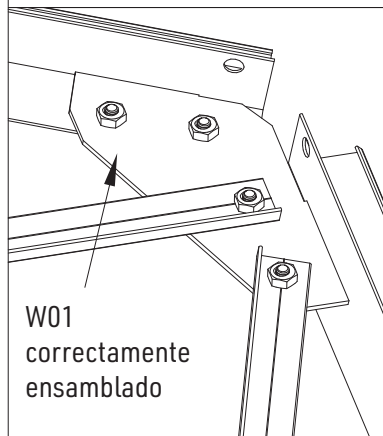

W01 correctamente ensamblado

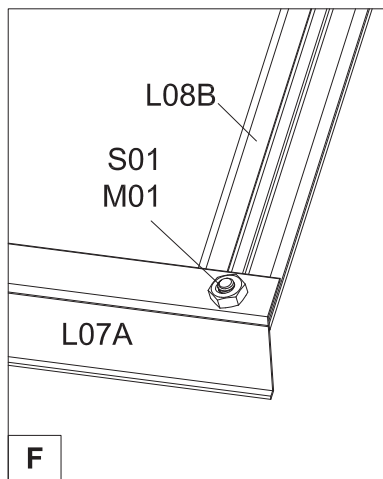

**F**

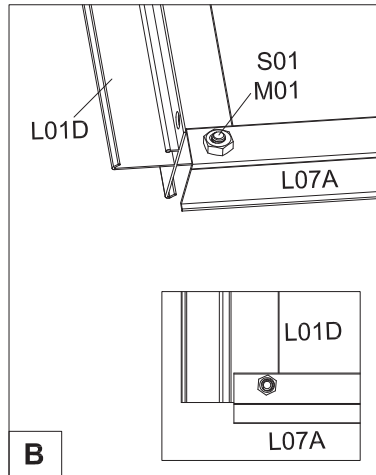

**B**

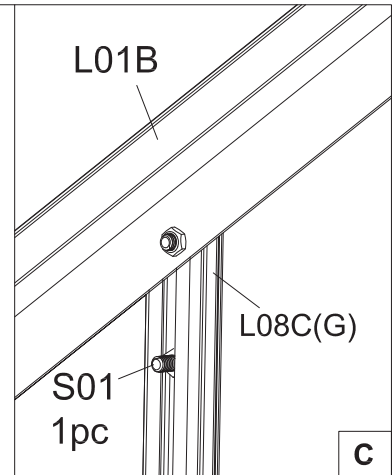

**C**

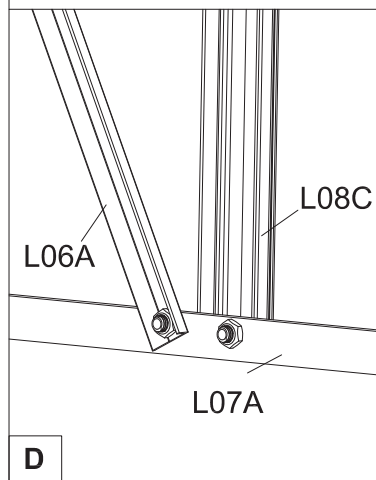

**D**

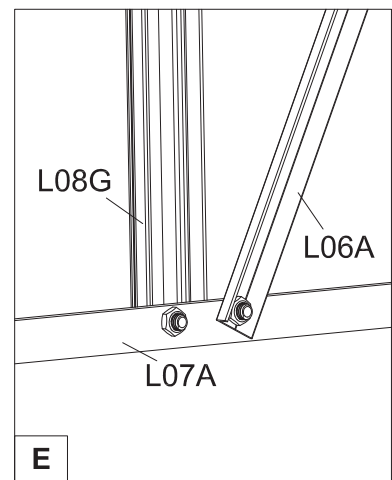

**E**

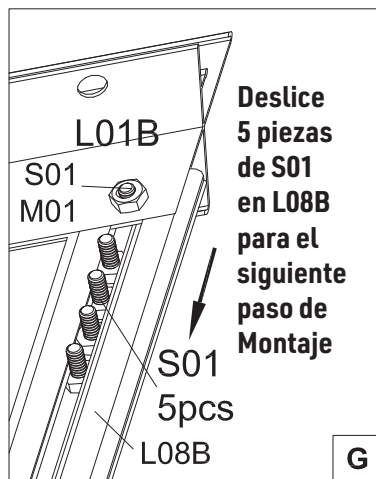

**G**

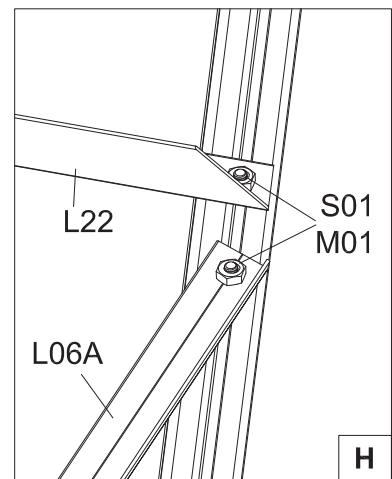

**H**

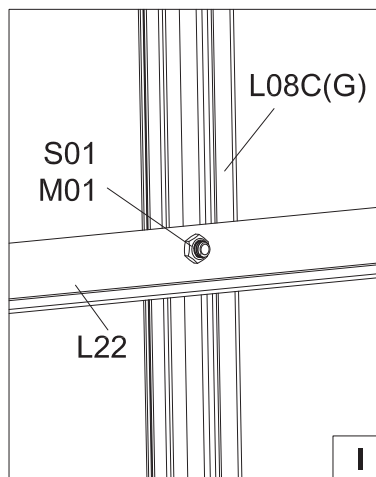

**I**



# Montaje de pared lateral

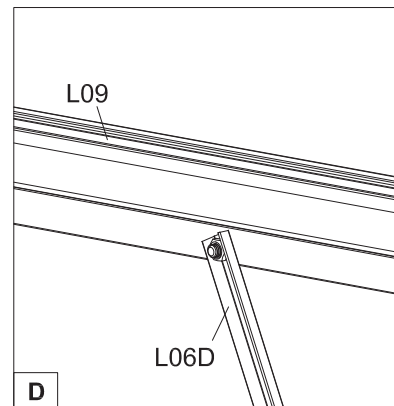
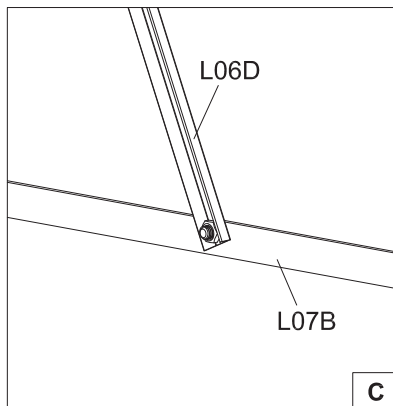
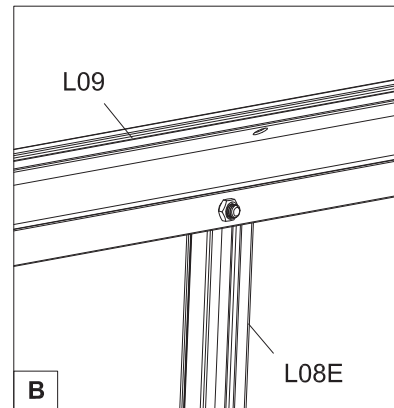
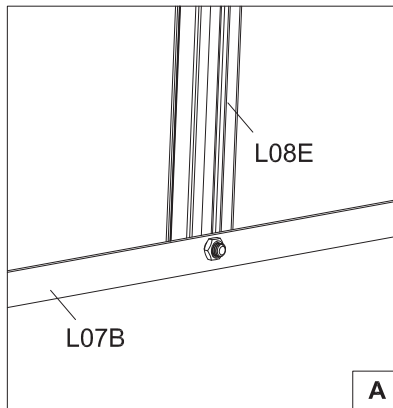
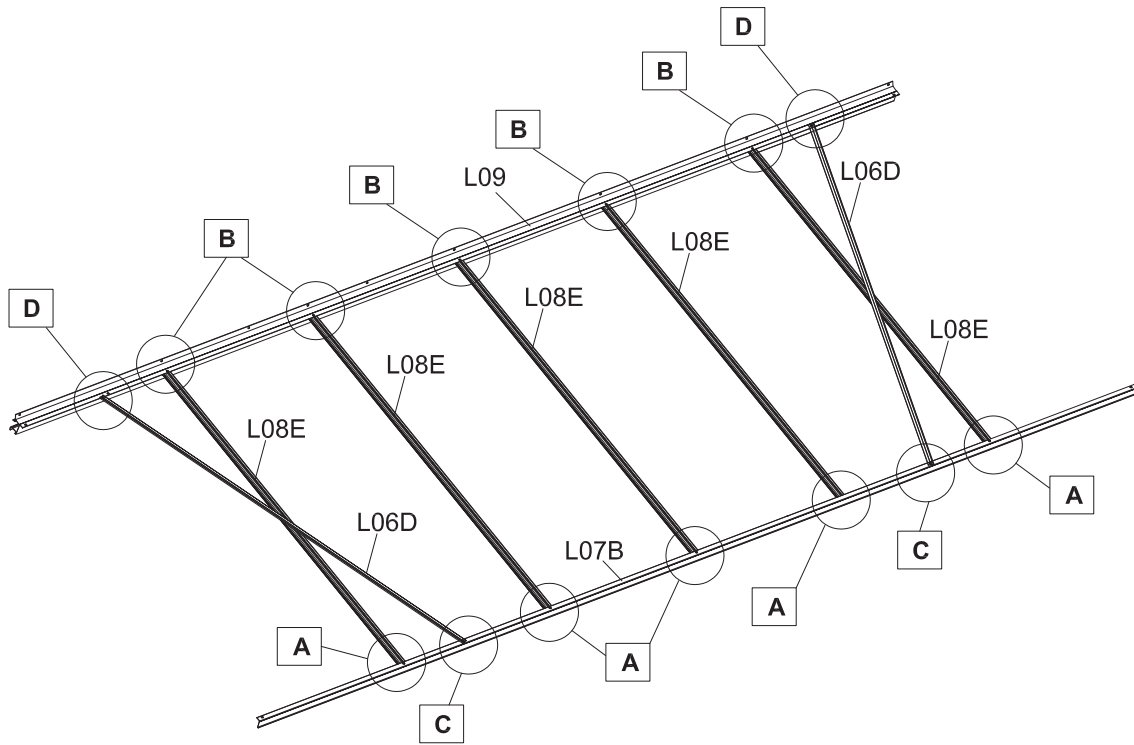

Rueda dentada trasera

Diente frontal

Pared lateral

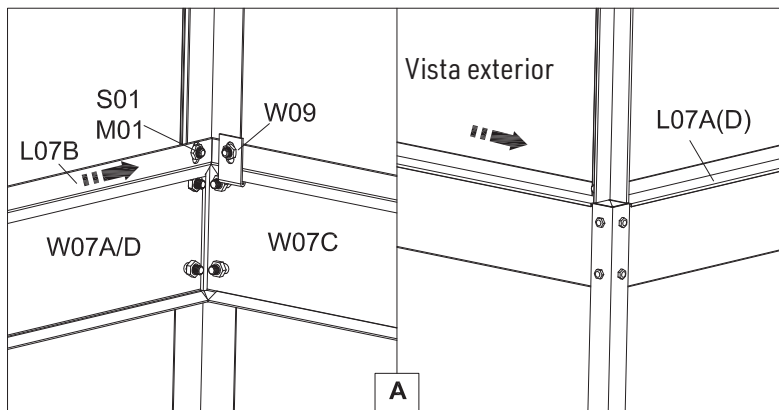
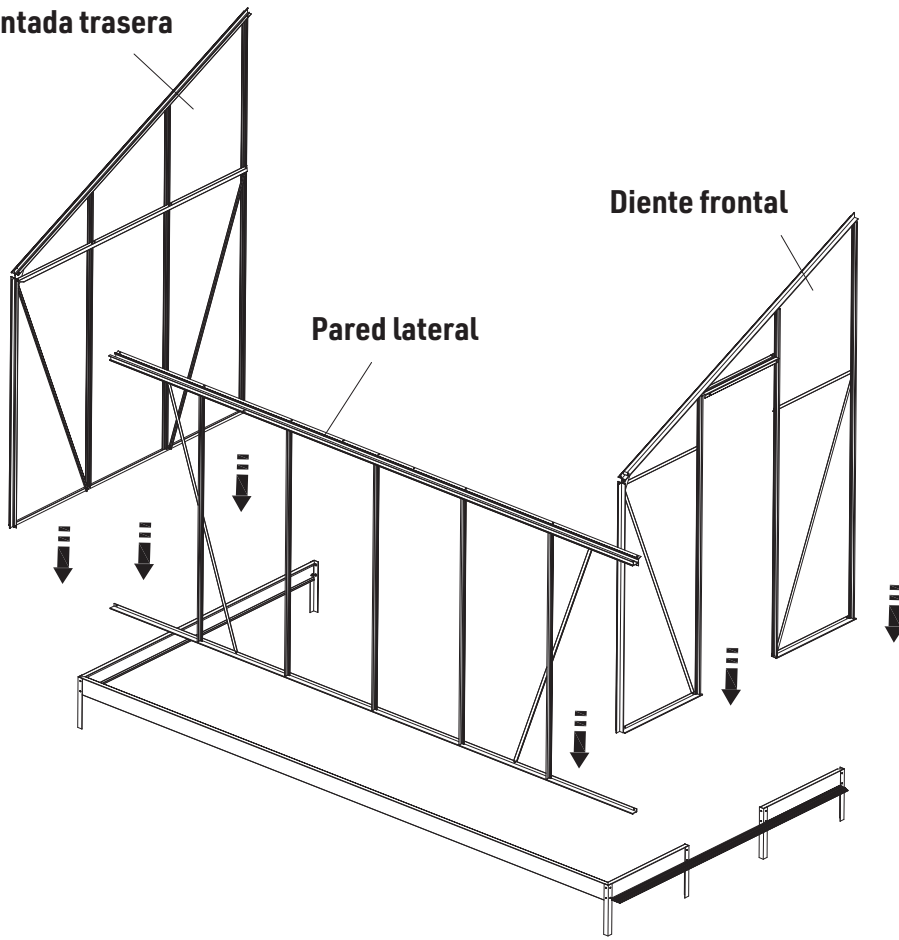

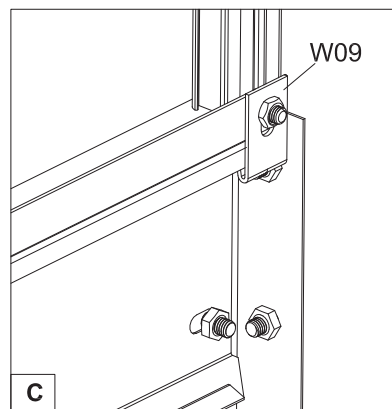
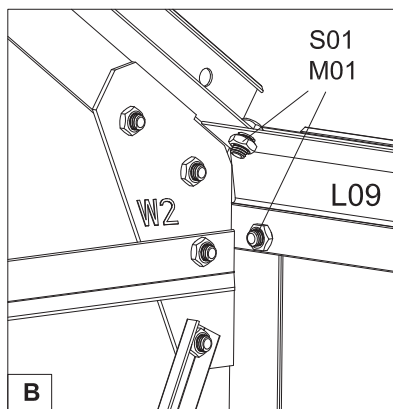
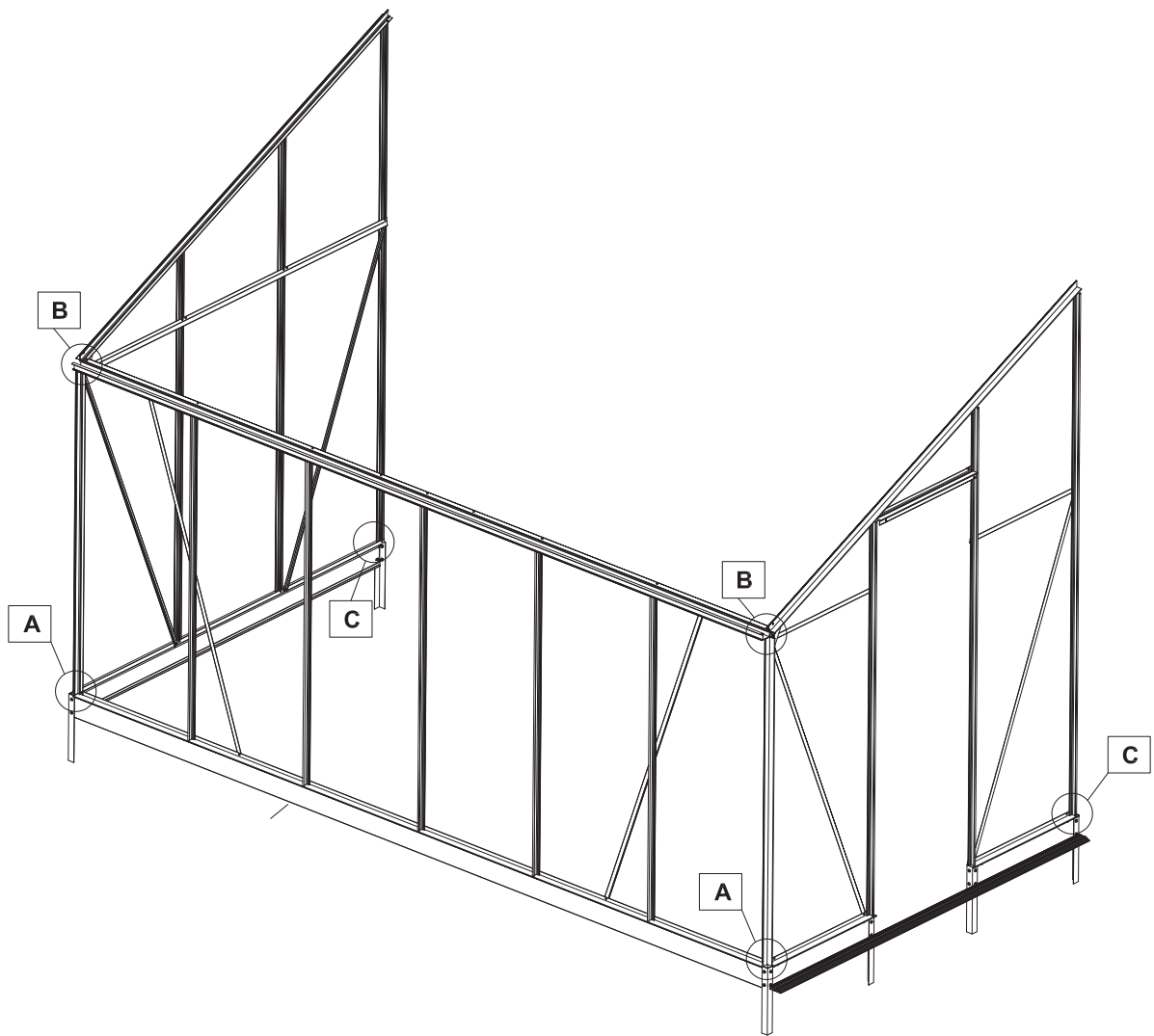

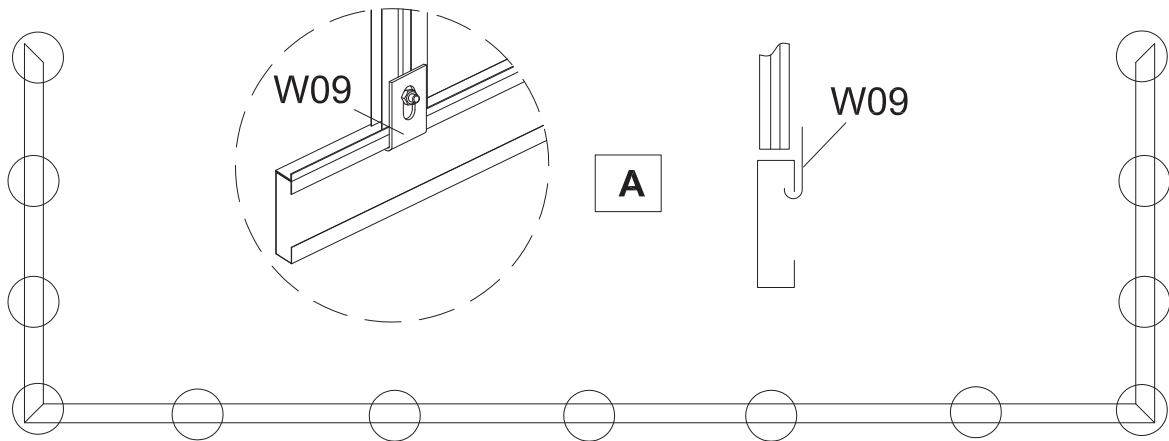
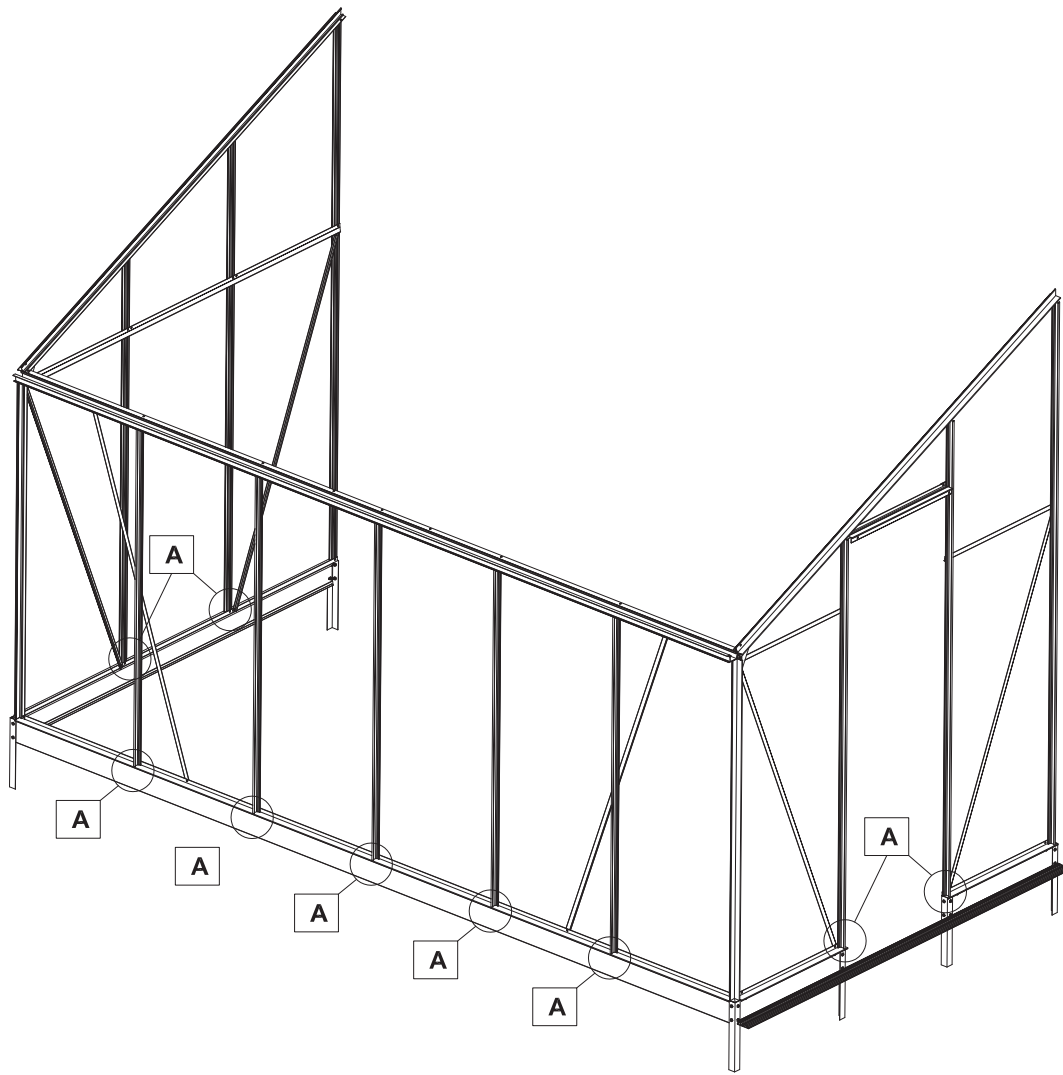

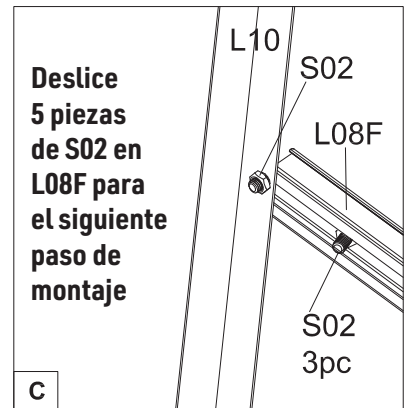
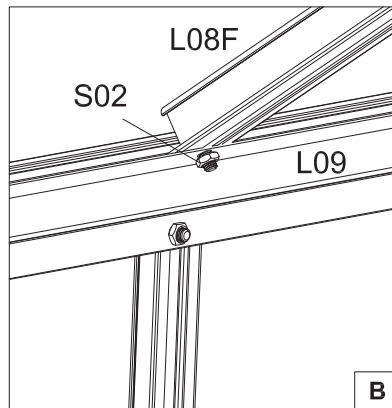
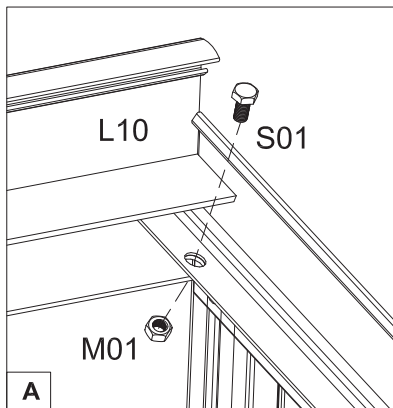
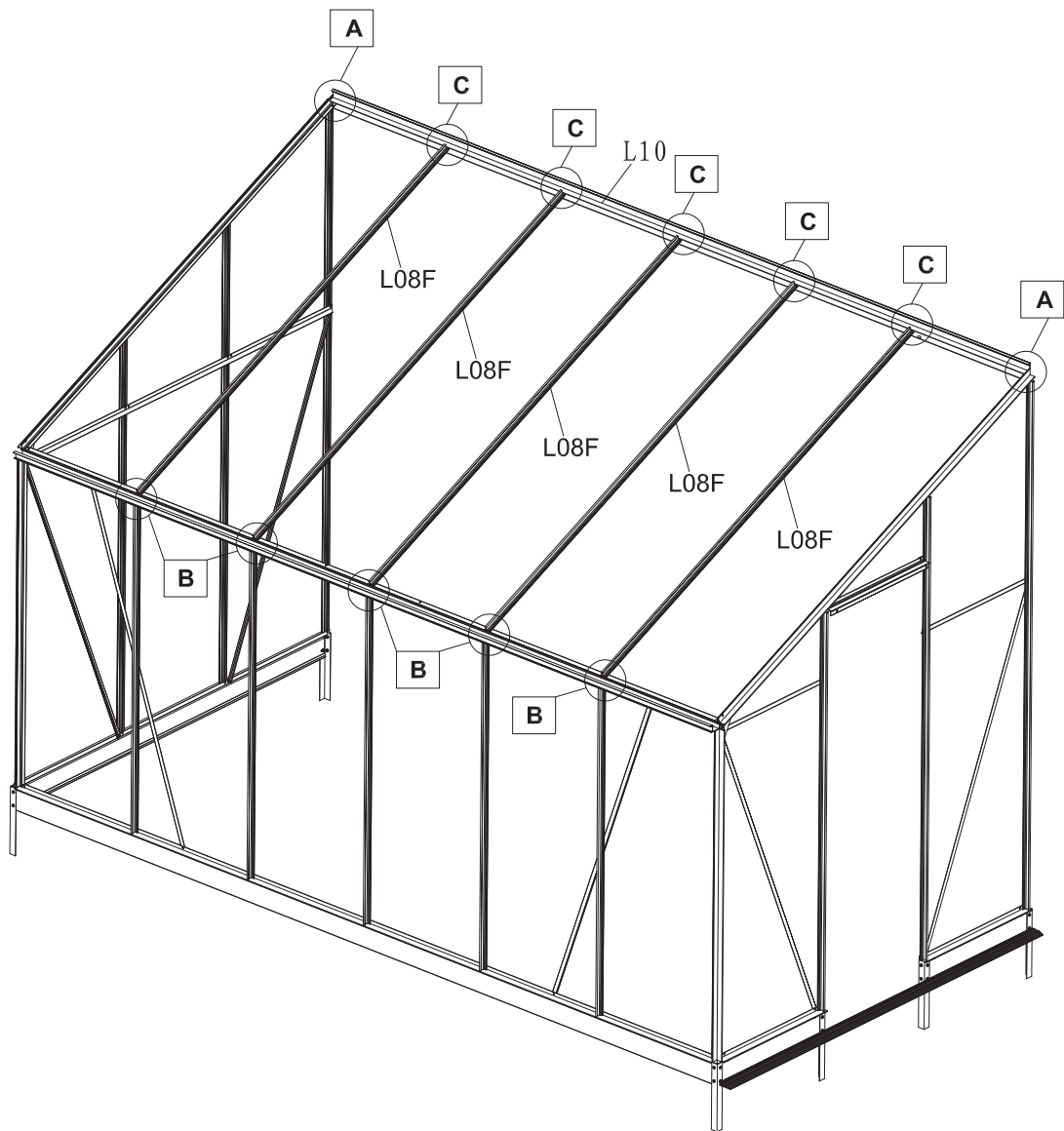

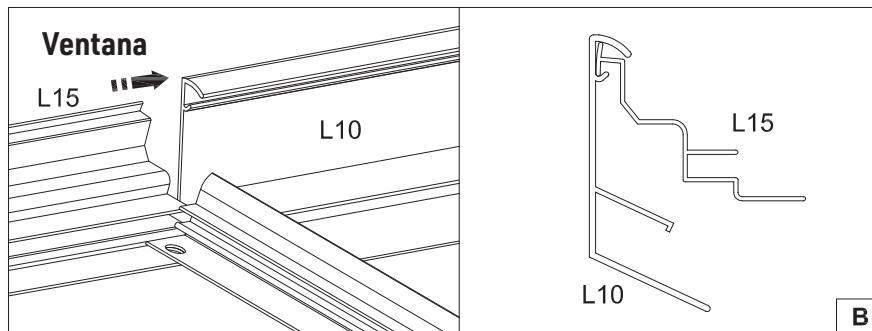
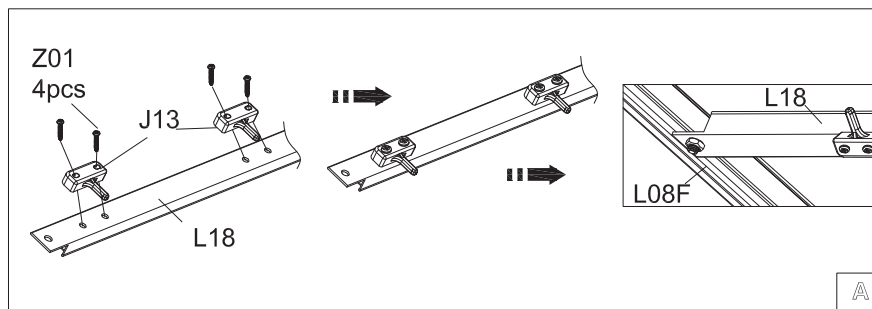
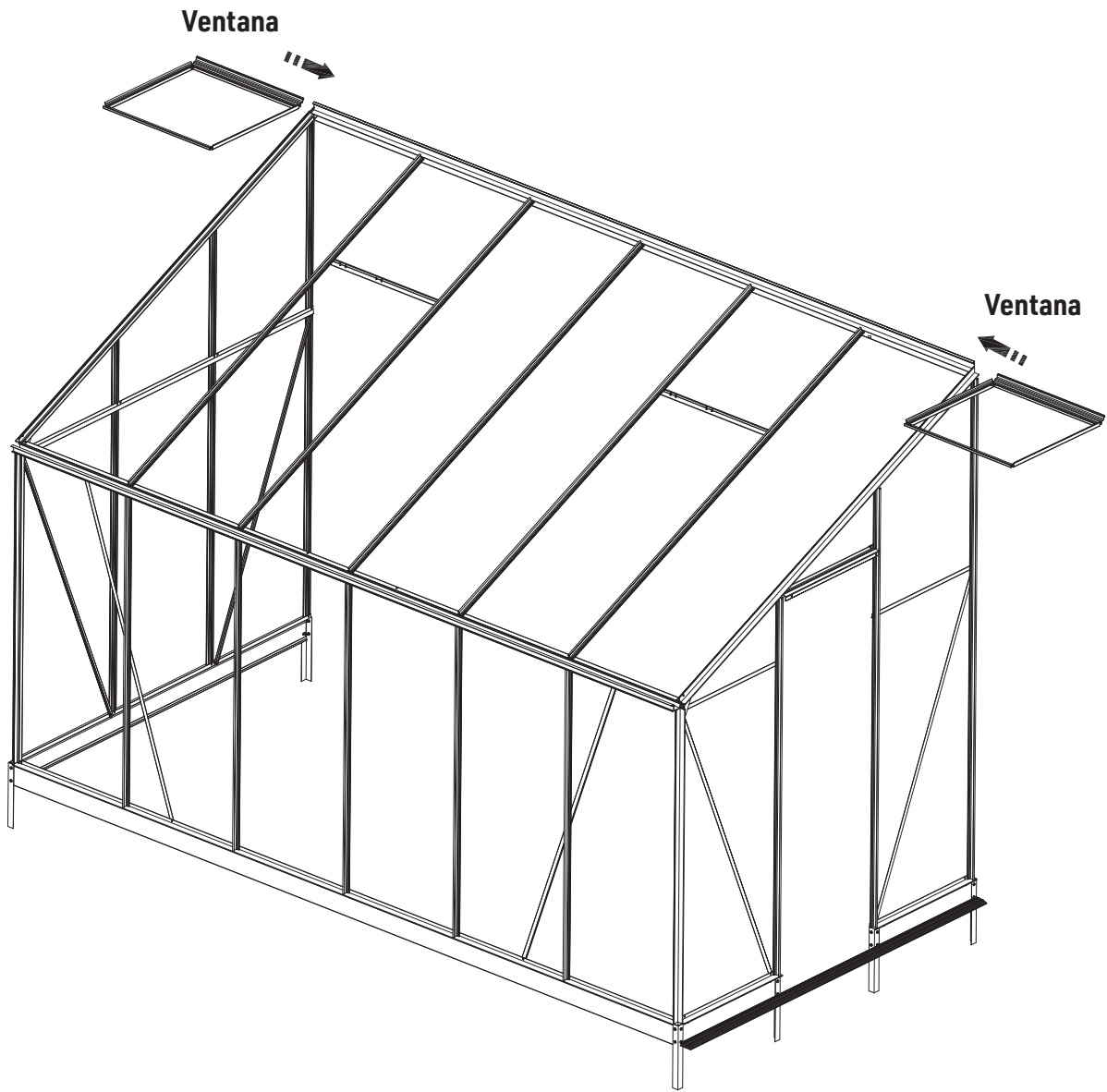

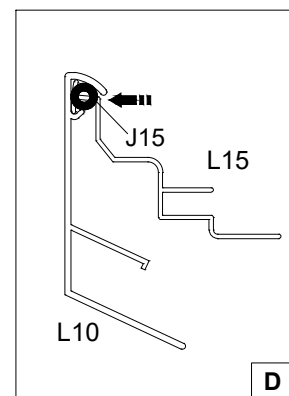
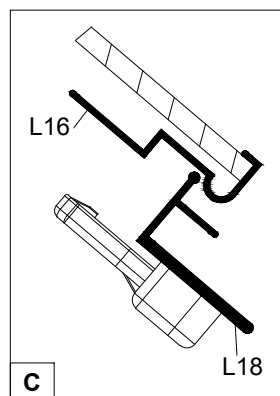
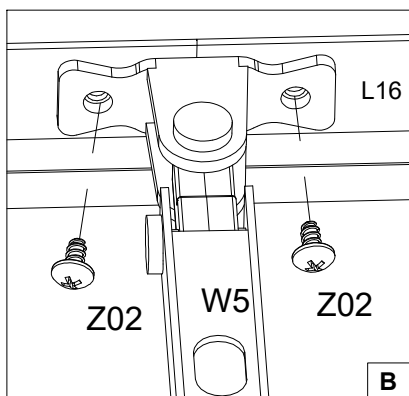
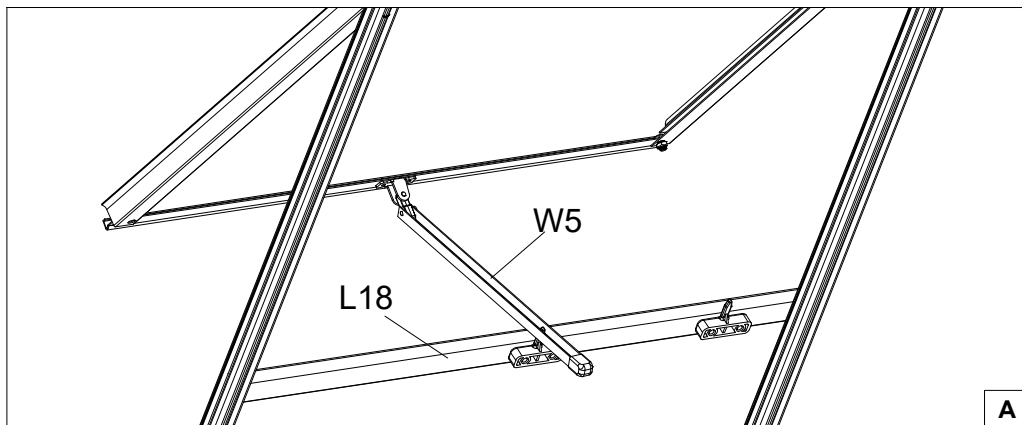
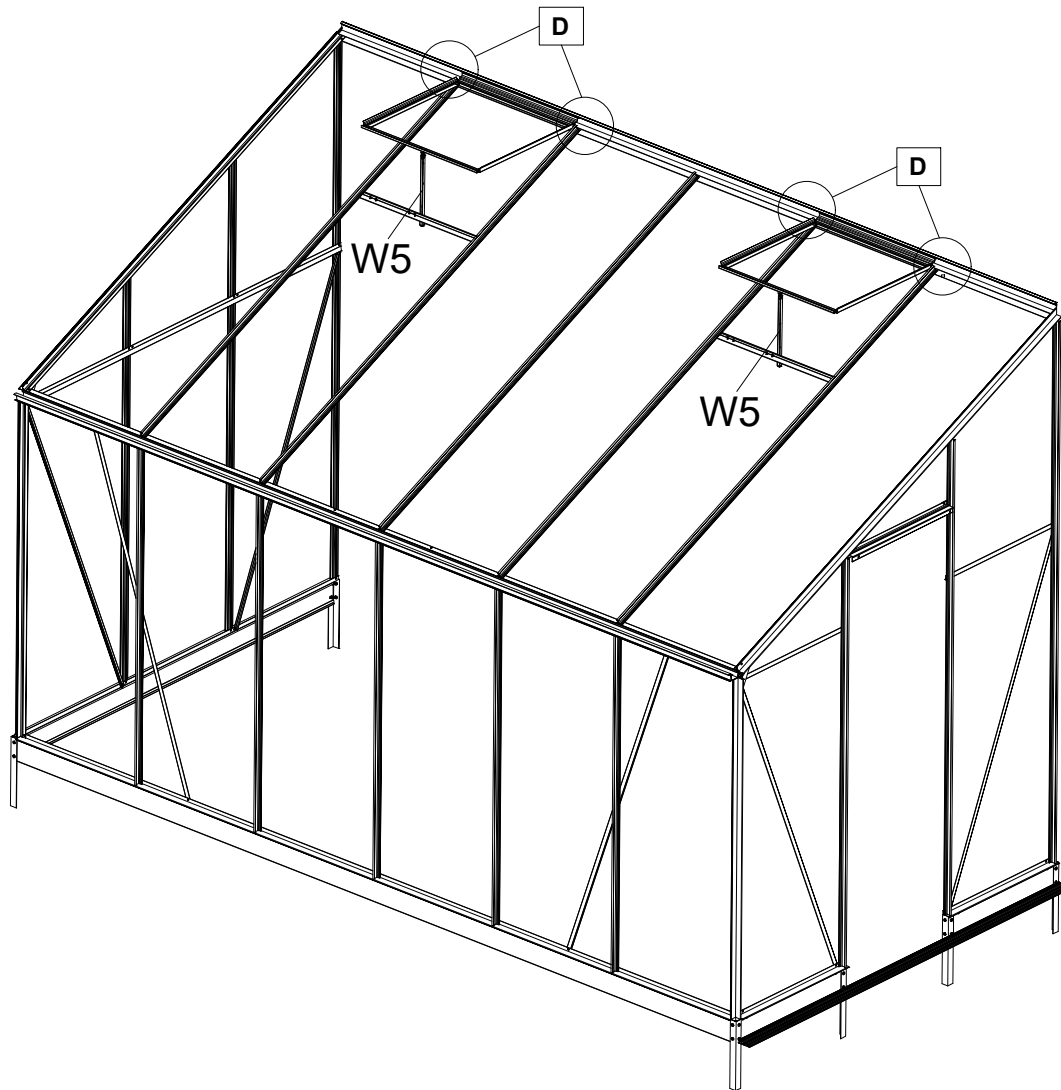

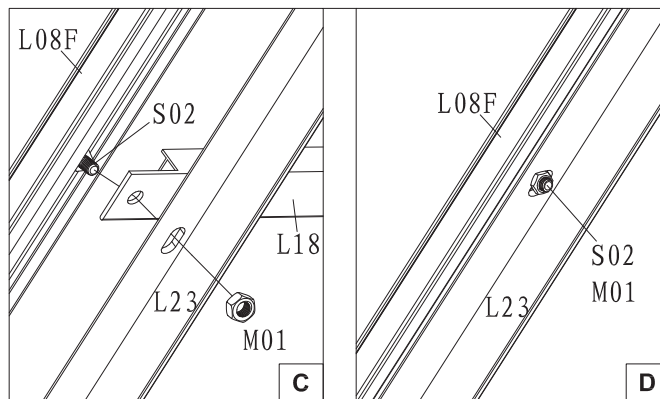
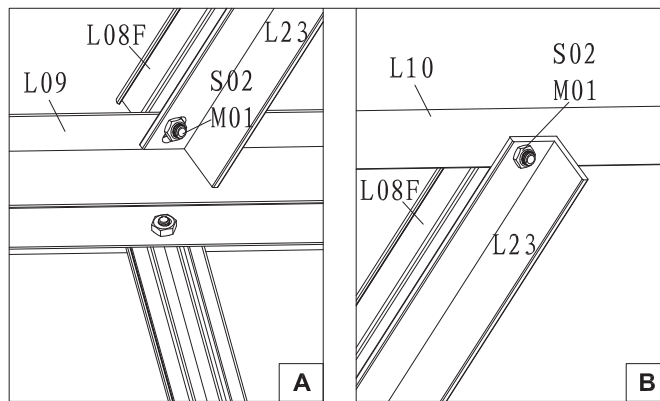
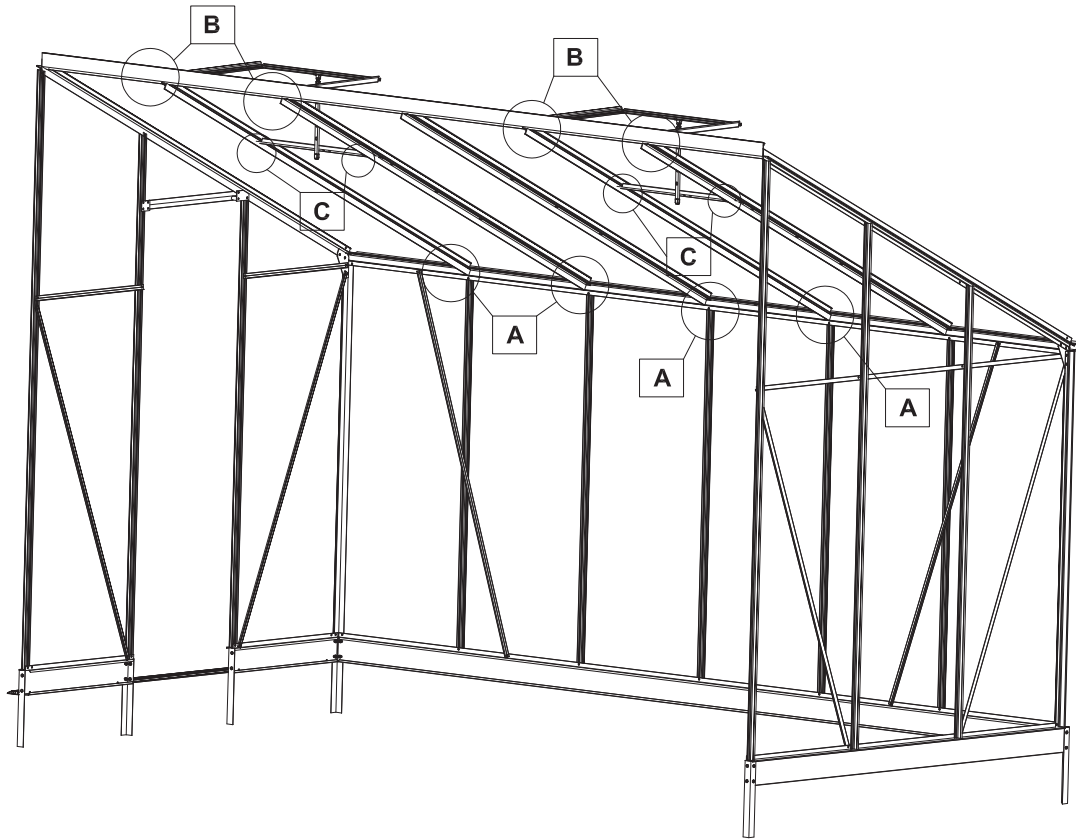

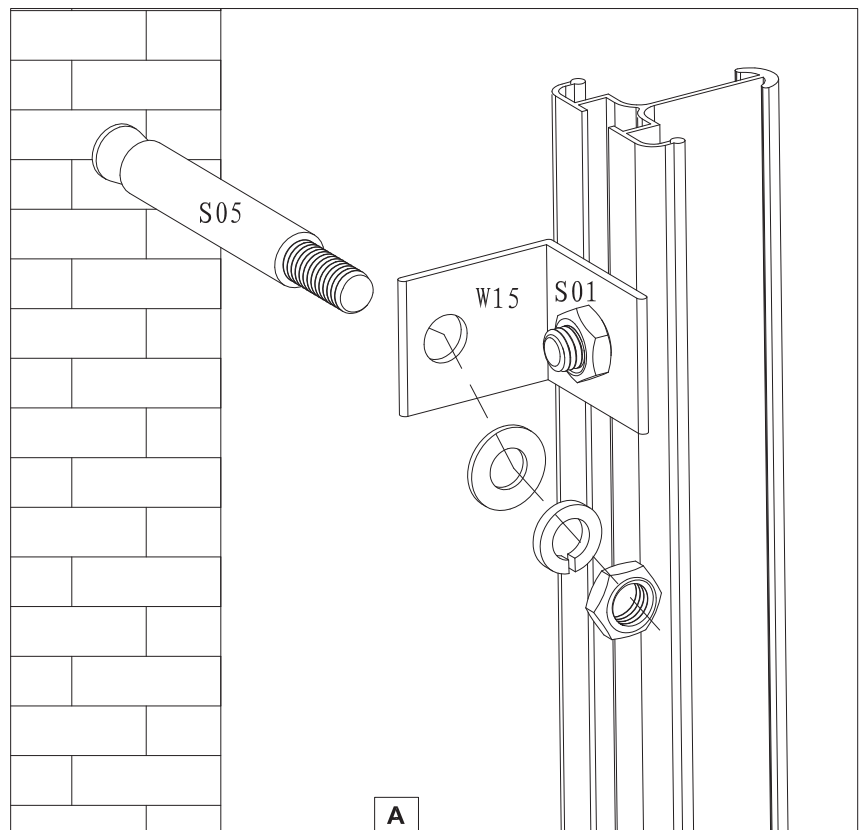
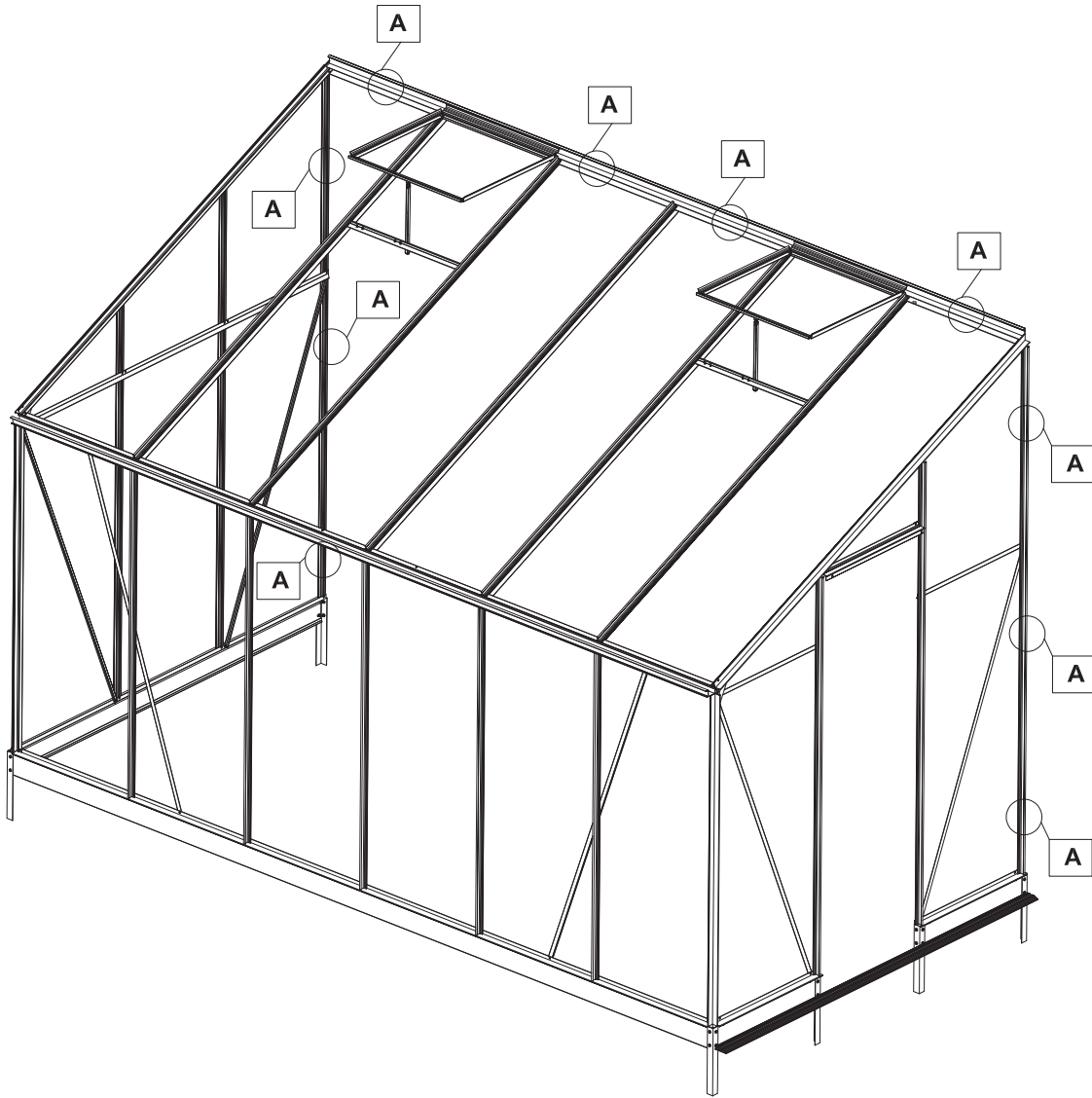

Instalación del sello de goma J19

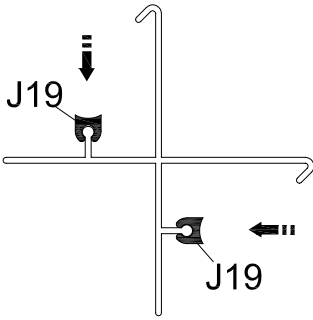

L01

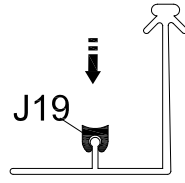

L03

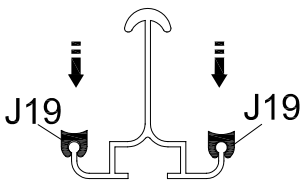

L08

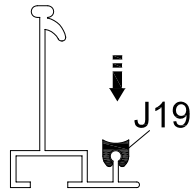

L11

Instalación de vasos

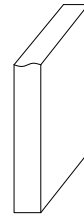
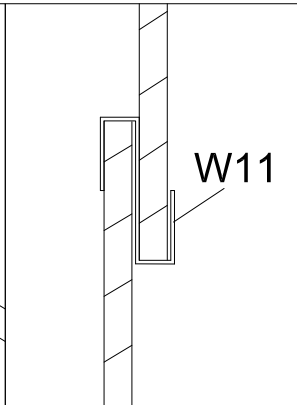
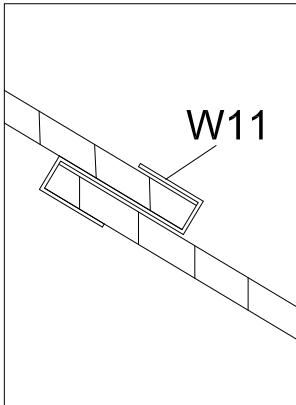
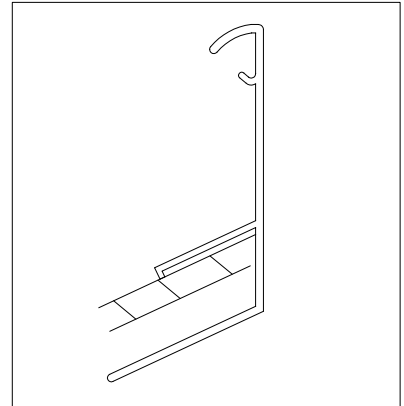
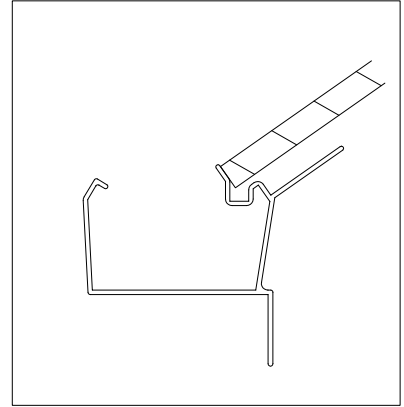

Tenga cuidado de no hacerse daño al manipular y ajustar las gafas

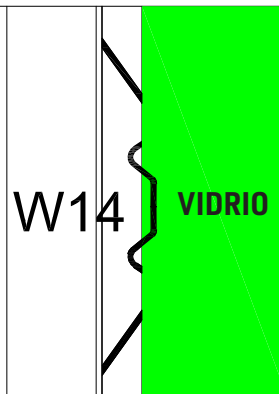
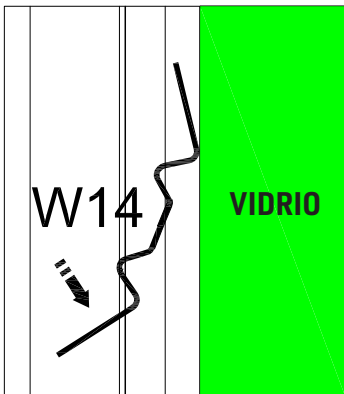
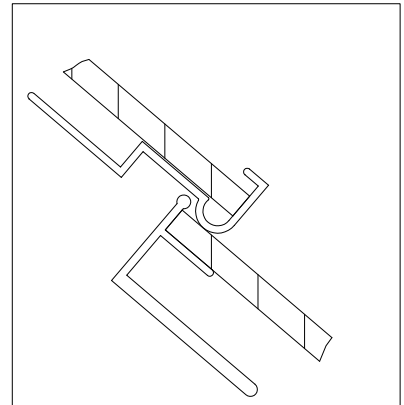

Tenga cuidado de no lesionarse al instalar los clips W14

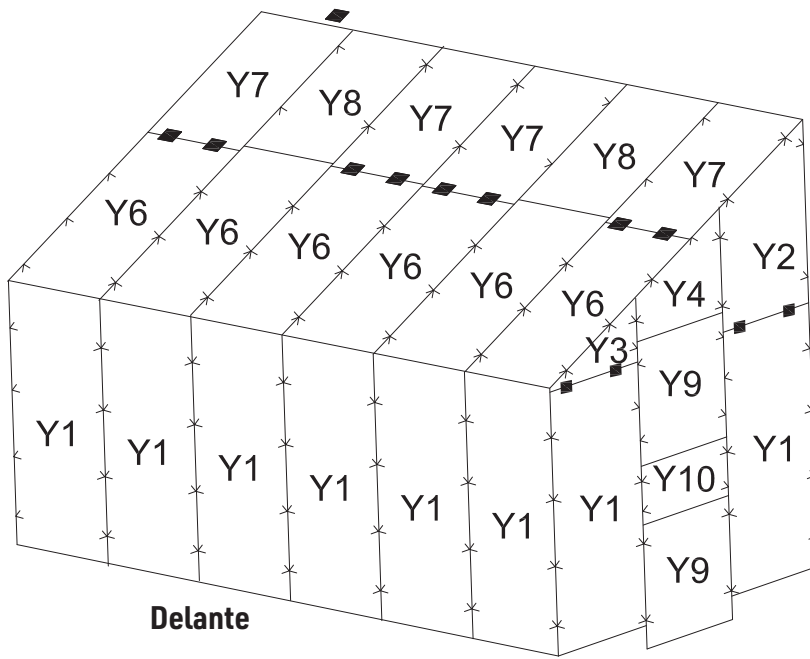

Delante

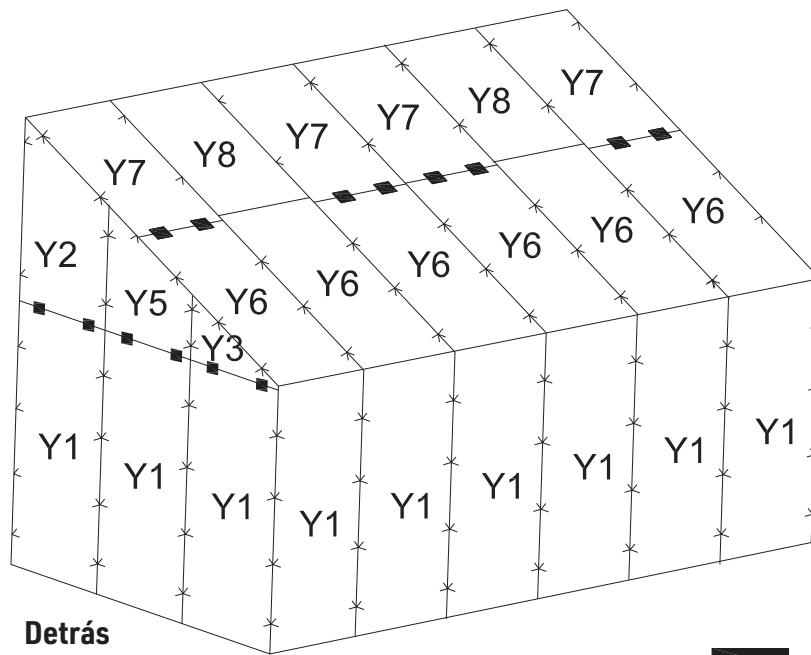

Detrás



Piezas	Ref	mm	Cant.
	Y1	610x1472	11
	Y2	610x904x619	2
	Y3	610x326x41	2
	Y4	608x292x10	1
	Y5	610x616X330	1

Piezas	Ref	mm	Cant.
	Y6	610x1338	6
	Y7	610x738	4
	Y8	602x726	2
	Y9	629x609	2
	Y10	629x395	1

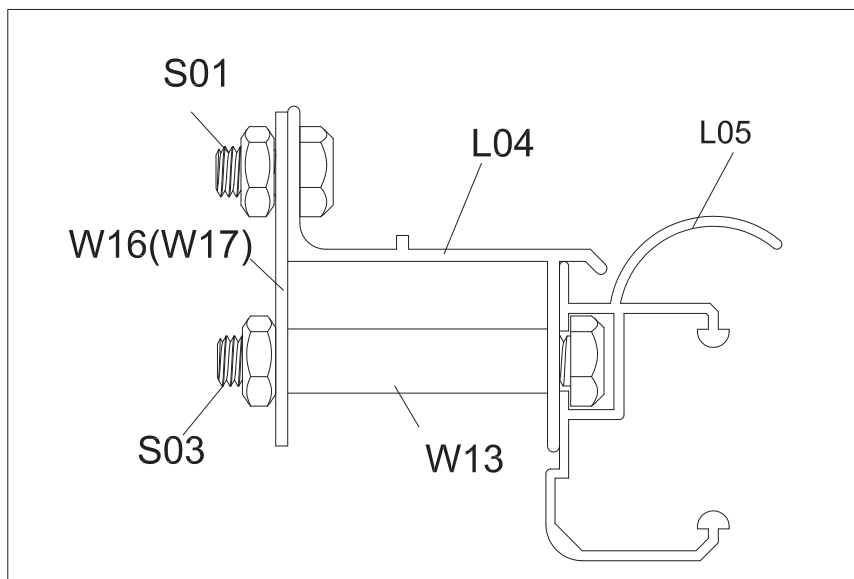
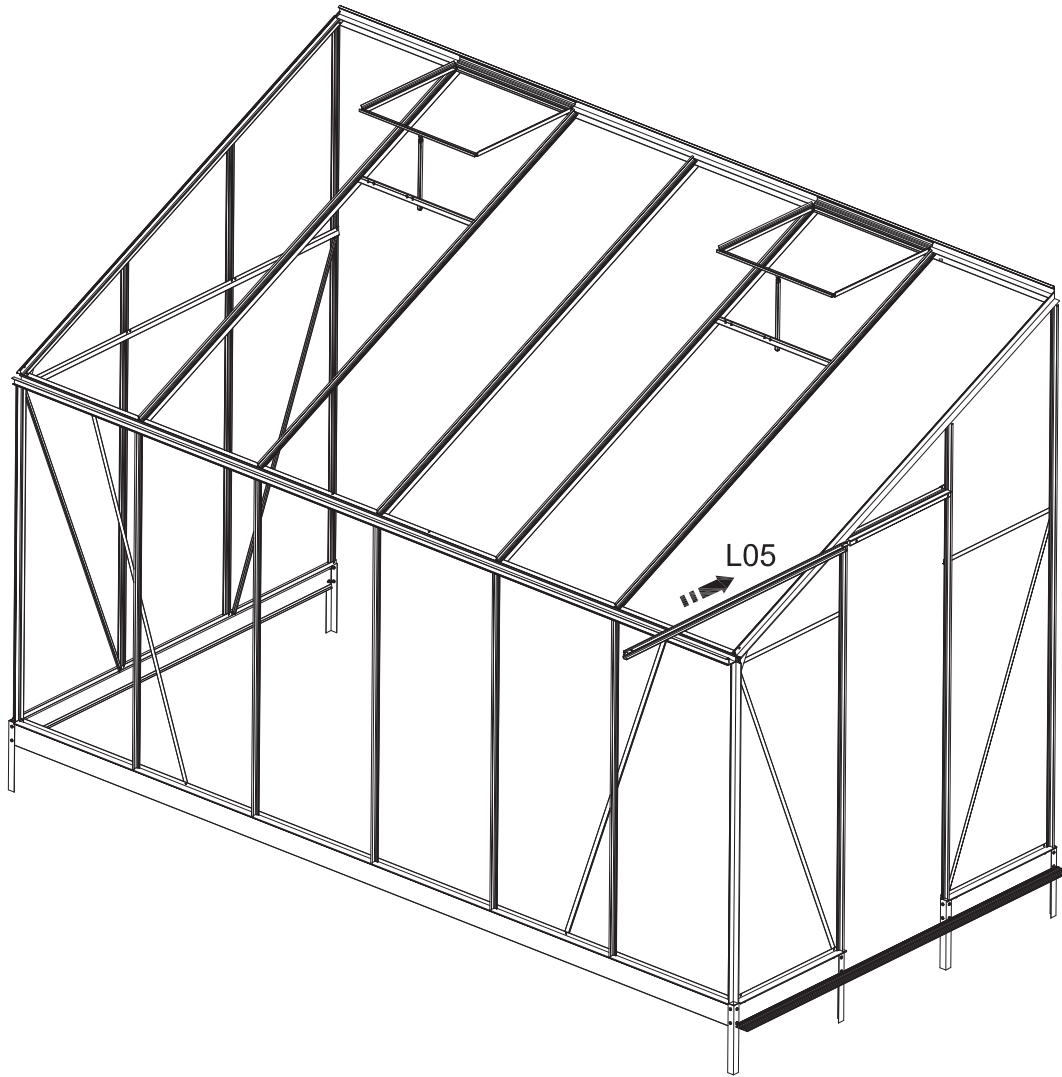

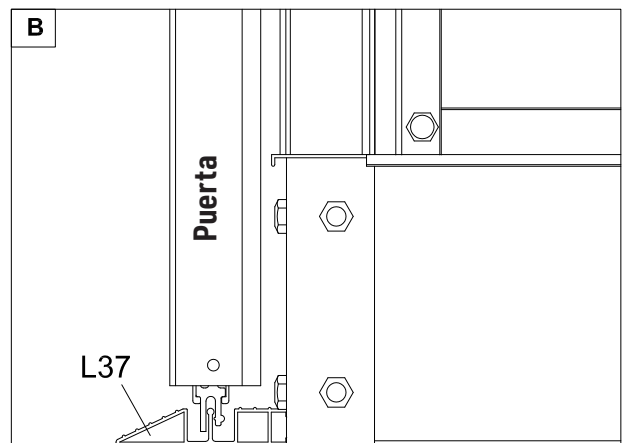
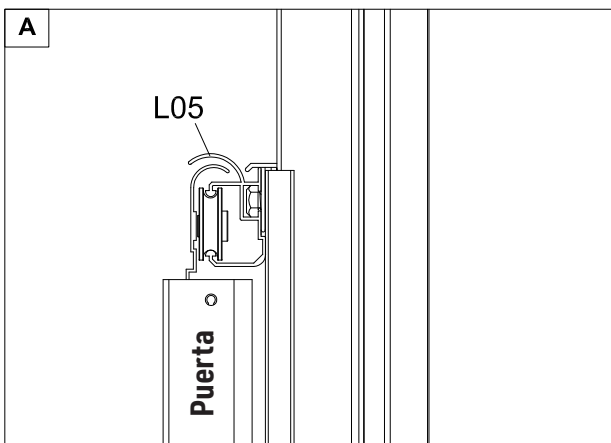
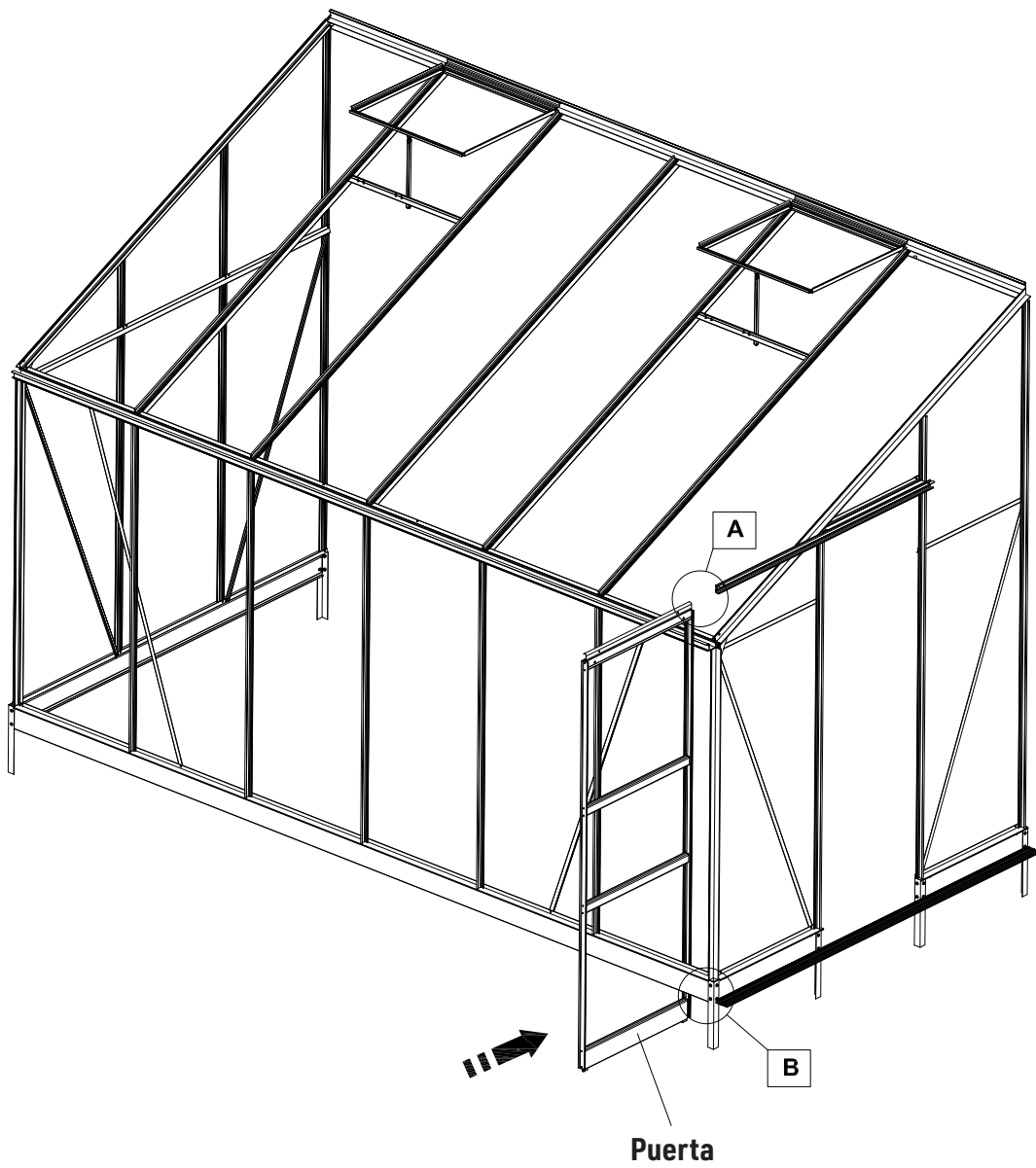

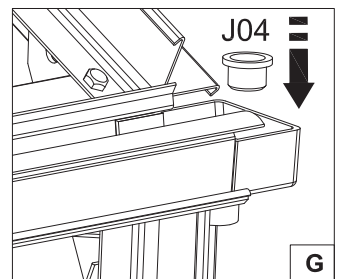
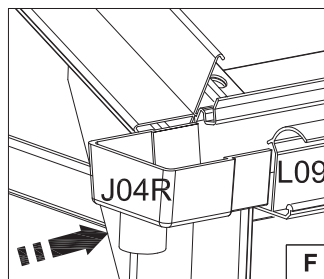
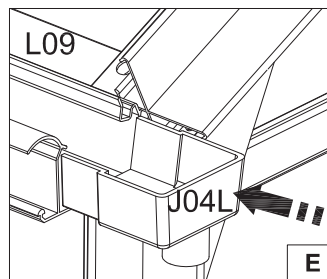
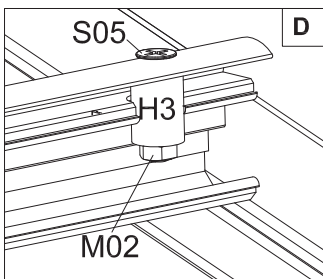
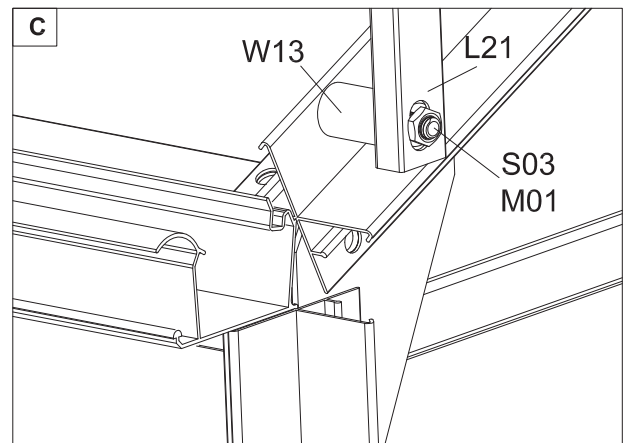
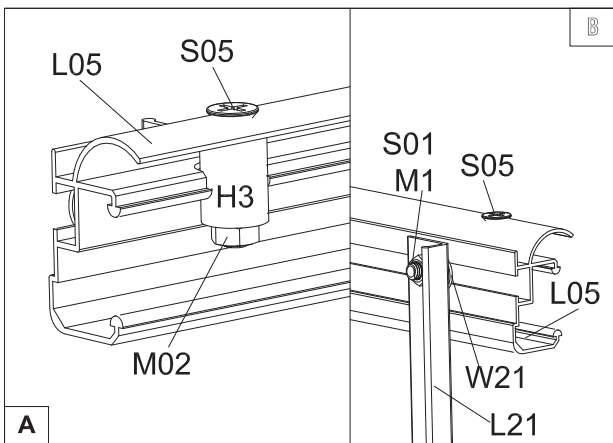
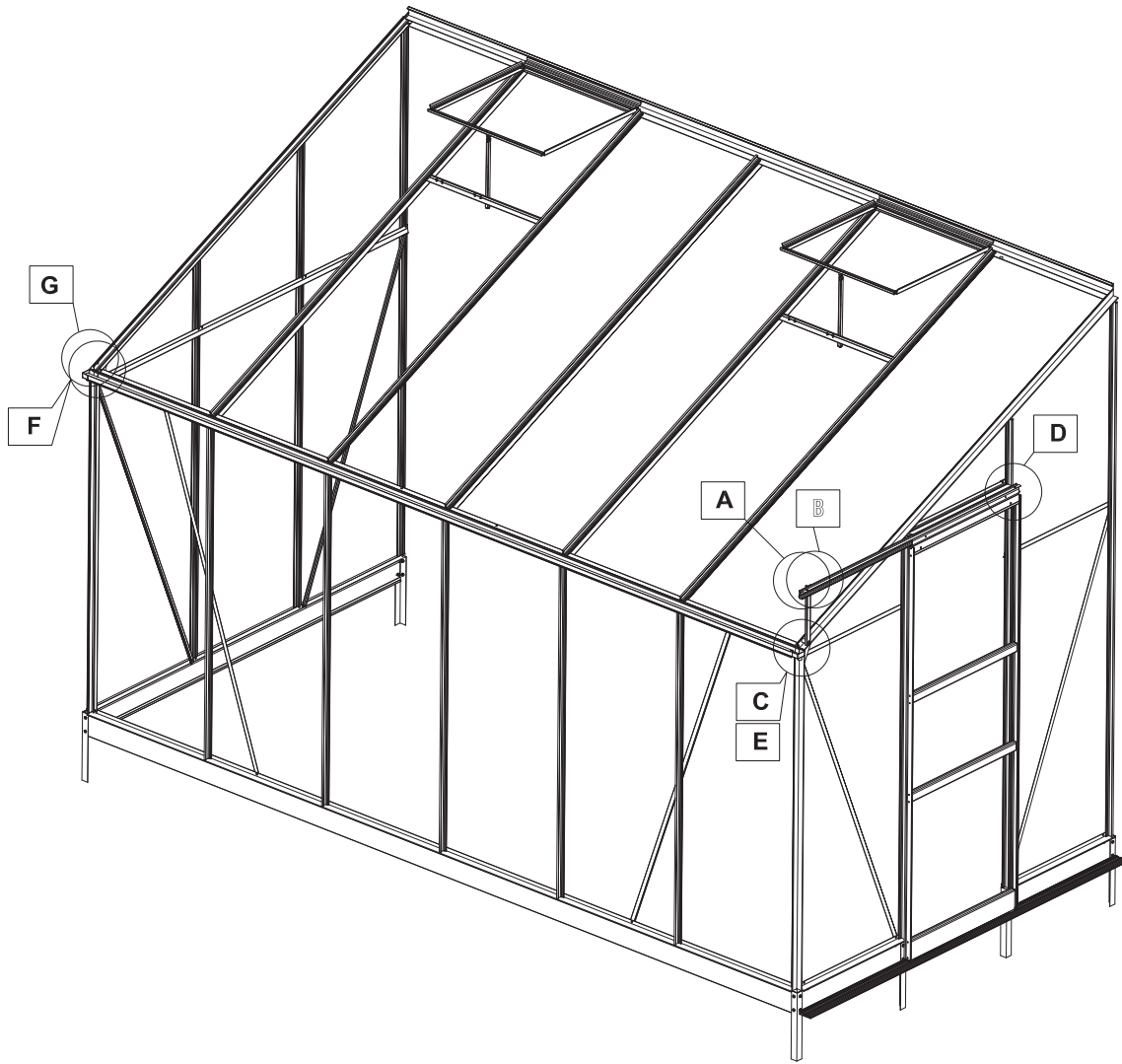

Caro cliente

Grazie per aver acquistato la serra da giardino Green Protect. Legga attentamente le seguenti istruzioni prima di procedere al montaggio.

**Attenzione: prima di iniziare con l'installazione della vostra serra, prendetevi il tempo necessario per identificare tutti i possibili pericoli come cavi o tubi interrati o aerei, ecc.**



### Luogo di installazione

- ☑ Una posizione soleggiata, aperta, esposta a nord, protetta dai venti forti, è il luogo più adatto per ottenere il meglio dalla vostra serra.
- ☑ La vostra serra deve essere posizionata su un terreno piatto e livellato. Per la base sono disponibili molte opzioni compatibili con ogni vostra esigenza. Le serre sono dotate di una base in grado di soddisfare la maggior parte dei requisiti di montaggio.
- ☑ L'accesso all'acqua e all'elettricità dovrebbe essere considerato in fase iniziale e prima che siano gettate delle solide fondamenta.
- ☑ Verificate di avere spazio sufficiente intorno alla serra durante l'installazione e successivamente, per la manutenzione.

### Montaggio





- ☑ Assemblate il telaio di alluminio (senza i vetri) e posizionatelo nel luogo scelto per installazione, in modo da poter scavare i fori per le fondamenta. Questo vi permetterà di individuare e segnare l'esatta posizione dei fori per l'ancoraggio dei pali.
- ☑ Una volta che avete segnato le posizioni di ancoraggio, spostate il telaio della serra per scavare i fori.
- ☑ Si raccomanda una profondità minima di 60 cm e un diametro di 20 cm. Una volta che i picchetti di ancoraggio sono attaccati alla base e alle staffe, è possibile sollevare la serra sopra i fori e abbassarla al livello del suolo.
- ☑ Una volta che siete soddisfatti della posizione finale e vi siete assicurati che il telaio sia livellato, piatto e abbia forma quadrata, potete versare il cemento nei fori di ancoraggio.





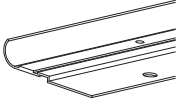
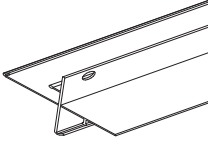
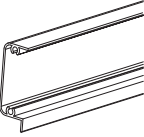
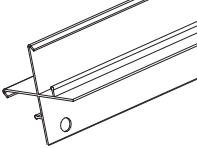
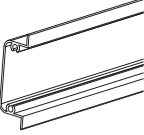
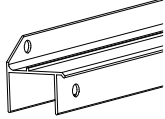
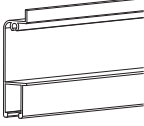
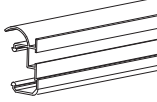
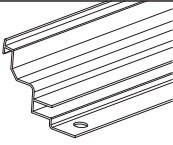
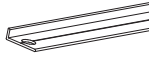
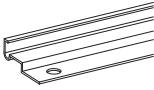
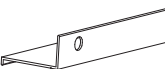
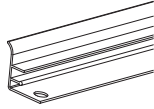
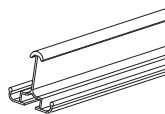
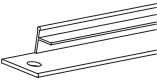
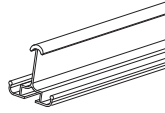
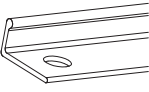
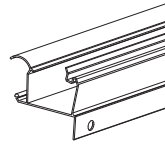
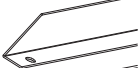
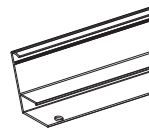

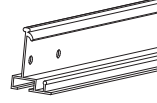



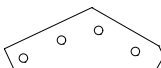

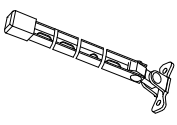

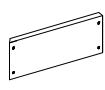



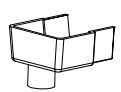

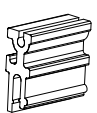
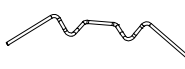
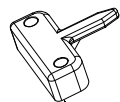

### Fissaggio su una base solida

- ☑ Usate la base fornita con il manuale di istruzioni come guida per costruire la vostra solida base, che sia in legno, mattoni, cemento, ...
- ☑ I fissaggi sono situati all'interno e a circa 55 mm dalla base in alluminio di 43 mm.

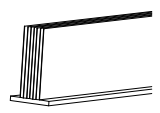
### Vetrate

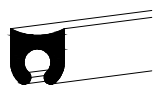
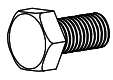
- ☑ Una volta che il telaio di alluminio è stato installato, potete iniziare con l'installazione delle vetrate.
- ☑ Anche se tutti i vetri di sicurezza sono temprati, essi devono sempre essere considerati come potenzialmente pericolosi. Maneggiateli con attenzione.
- ☑ Assicuratevi che il telaio sia libero da detriti prima di iniziare. Fate attenzione ai venti costanti.
- ☑ Se collocate i pannelli accanto alla serra durante la costruzione, vi suggeriamo di disporli in posizione inclinata.
- ☑ Iniziate con i pannelli del tetto e lavorate da un'estremità all'altra.
- ☑ Per inserire i pannelli del tetto, appoggiatevi alle grondaie e fateli scorrere tra le barre di rinforzo fino a quando non raggiungono il colmo, incastrandosi automaticamente.
- ☑ Fate scorrere i pannelli laterali tra le barre verticali in alluminio e spingeteli verso l'alto nella scanalatura sotto la grondaia.
- ☑ Assicuratevi che la parte inferiore del pannello di vetro poggi correttamente sulla parte superiore della base.
- ☑ Il pannello in posizione perpendicolare avrà un aspetto squadrato, e sarà assicurato dalle scanalature in alto e in basso.
- ☑ Inserite le guarnizioni di gomma aiutandovi con il pollice e l'indice.
- ☑ Tutte le guarnizioni in gomma sono più lunghe del necessario e devono essere tagliate in fase di regolazione.
- ☑ Se l'estrusione di gomma appare asciutta, usate acqua e sapone per facilitare l'installazione nella barra di vetro.
- ☑ Le guarnizioni dovrebbero apparire piatte e dritte una volta fissate.
- ☑ Fate riposare le guarnizioni per un'ora o due prima di tagliarle a misura, poiché possono allungarsi e poi restringersi durante l'installazione.
- ☑ Non tagliate le guarnizioni finché non le avrete inserite tutte.

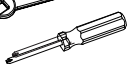
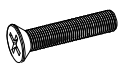
Parte	#	mm	Qtà	Parte	#	mm	Qtà
	L12	640	1		L01A L01B	2073 2073	1 1
	L13A	640	1		L01C L01D	1474 1474	1 1
	L13B	640	2		L04	592	1
	L38	640	1		L05	1300	1
	L15	602	2		L06A L06B L06C L06D	1547 620 640 1558	4 1 1 2
	L16	602	2		L07A L07B L07C L07D	1869 3706 626 646	1 1 1 1
	L17	700	4		L08A L08B L08C L08D	2358 2358 1780 1780	1 1 1 1
	L18	638	2		L08E L08F L08G L08H	1474 2046 2069 2069	5 5 1 1
	L21	259	1		L09	3708	1
	L22	1865	1		L10	3708	1
	L23	2042	5		L11A L11B	1816 1816	1 1
	L37	1842	1				

Parte	#	mm	Qtà	Parte	#	mm	Qtà
	M01	M6	113		W2		2
	M02	M5	2				
	Z01	Ø4*16	24		W5		2
	Z02	Ø4*6	4				
	H3		2		W07A	655	1
					W07B	645	1
					W07C	3758	1
					W07D	1900	1
	J04		1		W08	350	6
					W09		13
	J04L		1		W11		20
	J04R		1		W13	Ø12*28	3
	J11		2		W14		210
	J13		4		W15		6
					W21	Ø12*Ø6*1.5	2
	J15	Ø6.5*20	4		W16		1
					W17		1
	J18	1.82M	2		W46		2
	J19	78M	1		S01	M6*10	90
					S02	M6*16	24
					S03	M6*40	3
	T01		1		S04	M6*14	5
	T02		1		S05	M5*25	2
	S04				S07	M6*60	12

**Suggerimento importante:**

Non è necessario smontare tutto se avete dimenticato di mettere le S01 viti, potete sostituirle con le viti S04!

## Montaggio della base

È essenziale che la base della serra sia perfettamente quadrata in modo che le misure delle diagonali siano identiche. La serra deve anche essere uniformemente livellata nella parte anteriore e posteriore e avere una perpendicolarità perfetta.

L'ancoraggio della serra nel terreno è essenziale. Se disponete di una lastra, vi consigliamo di utilizzare gli ancoraggi in muratura e di tagliare le staffe di ancoraggio.

In alternativa, gli ancoraggi possono essere cementati nel terreno (basamento di almeno 300 mm di diametro e 400 mm di profondità). Spesso è meglio effettuare questa operazione alla fine, se il tempo lo permette. Fissare sempre la struttura temporaneamente durante l'installazione.

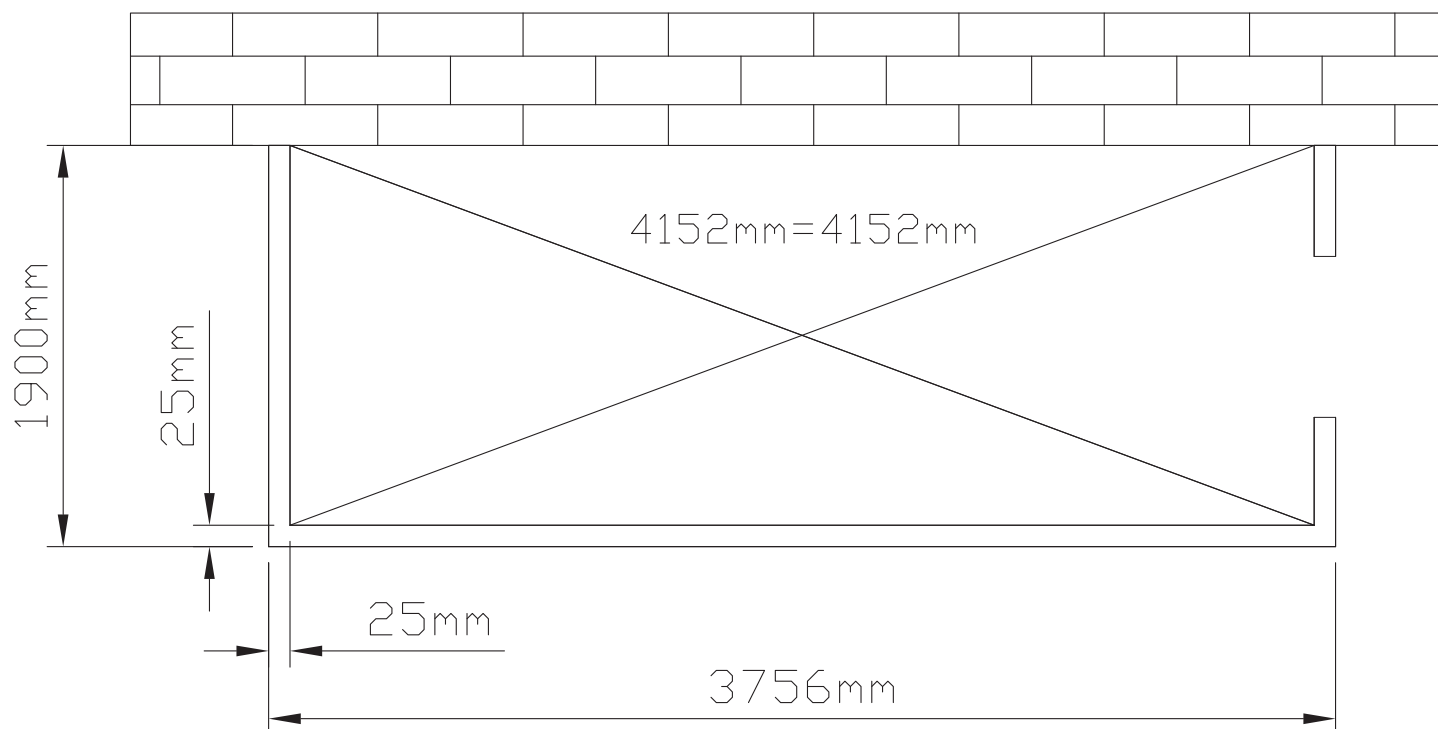
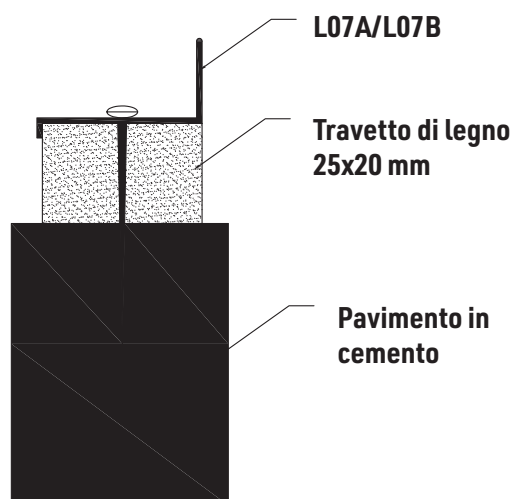

# Montaggio della base

**Nota:** Si prega di rimuovere la pellicola protettiva sulla superficie delle parti W08 e W07 A (B/C/D) prima di assemblare la base

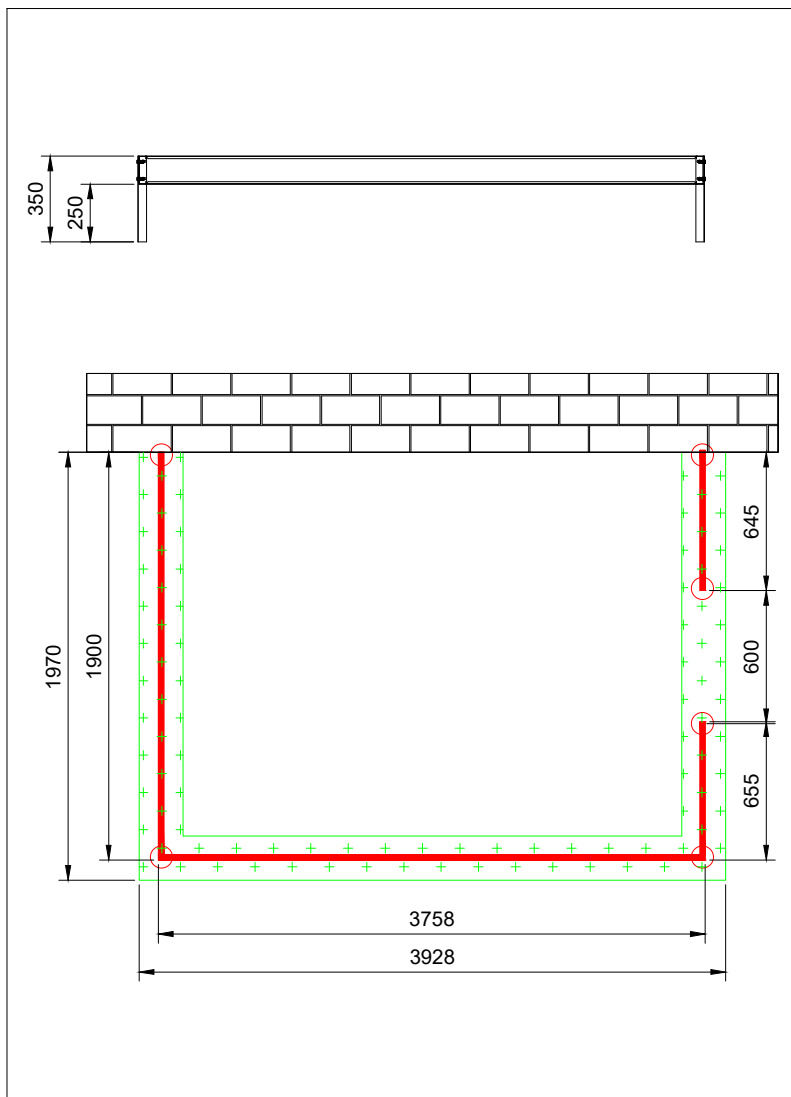
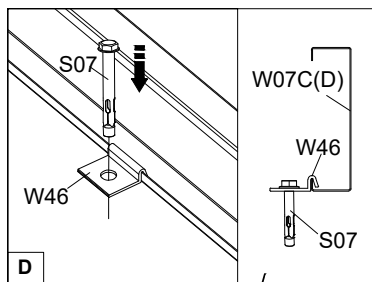
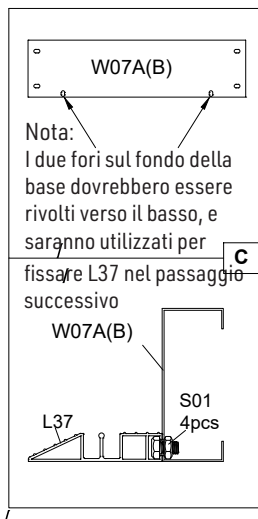
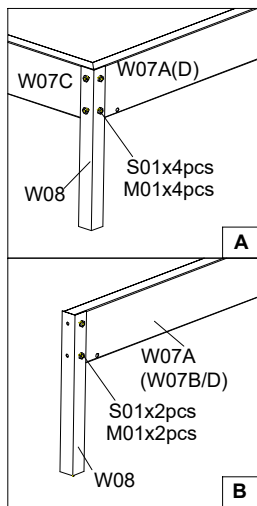
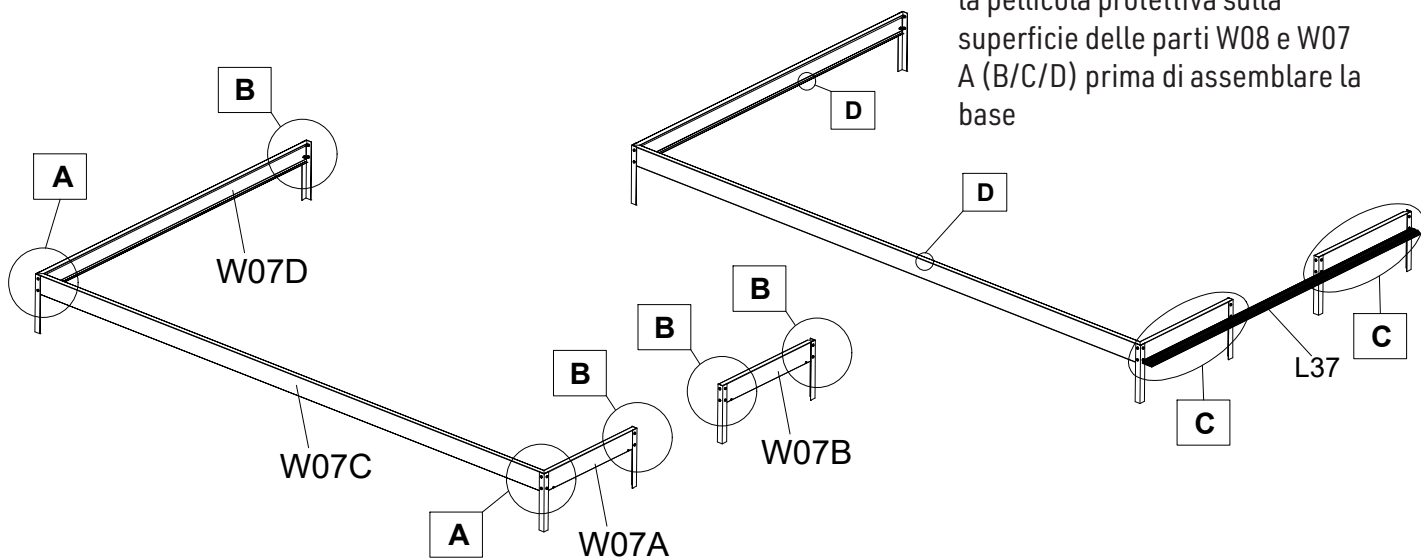

# Montaggio della porta sinistra

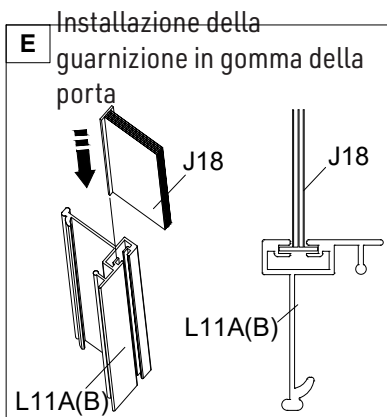
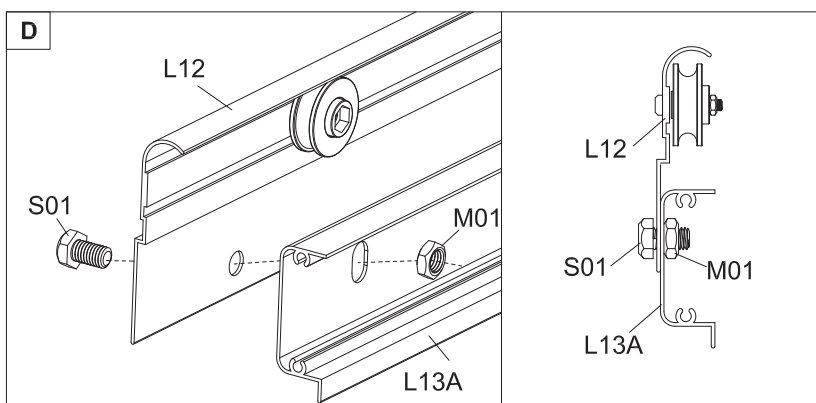
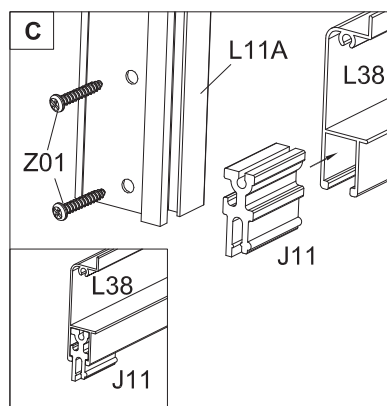
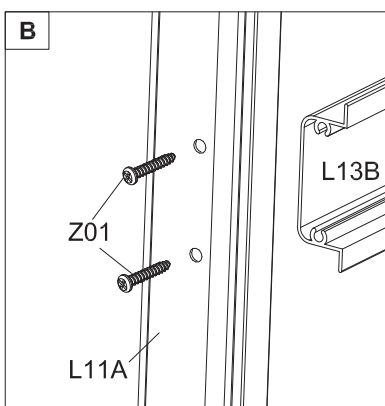
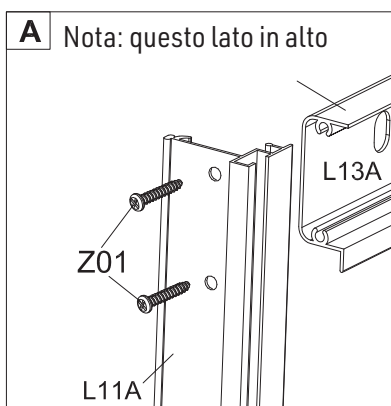
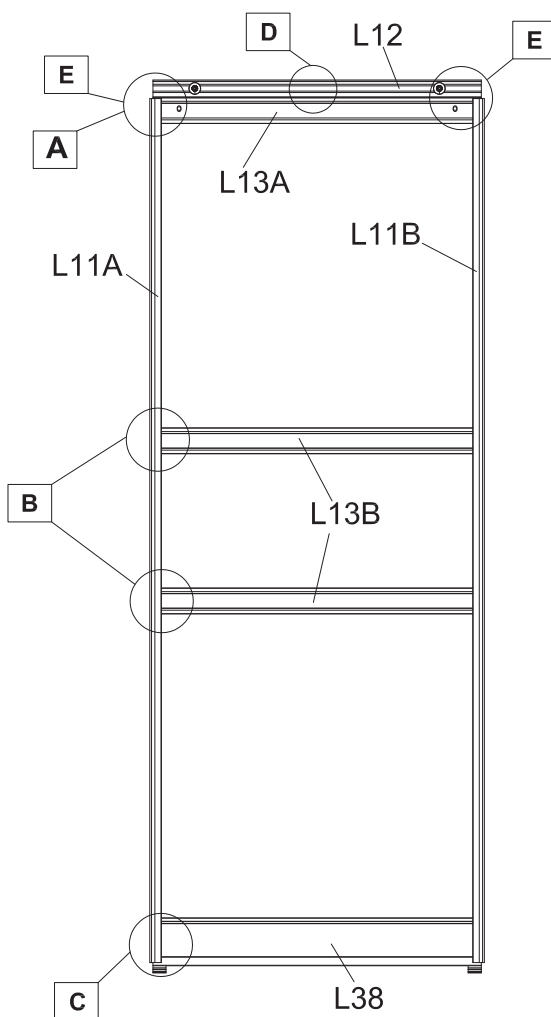

# Montaggio della finestra

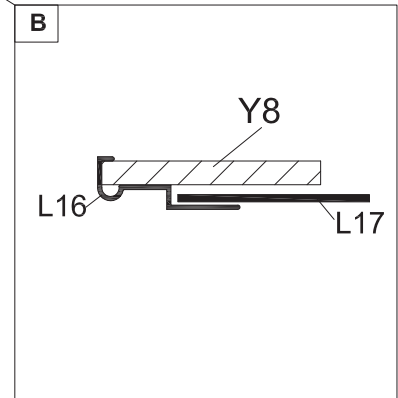
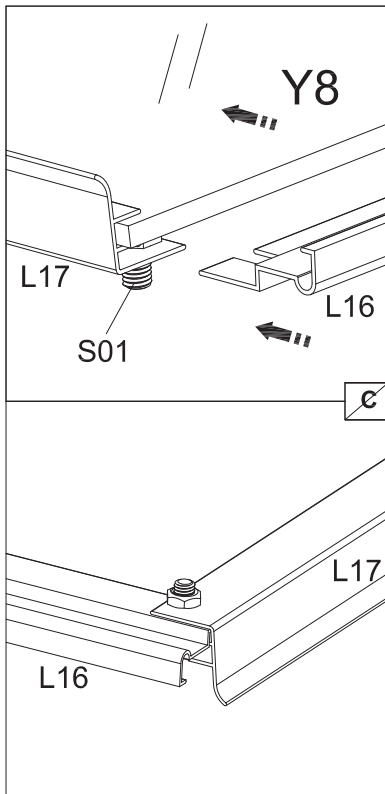
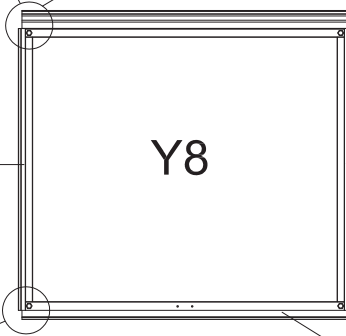
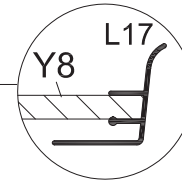
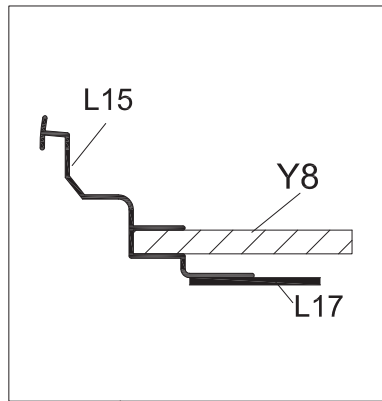
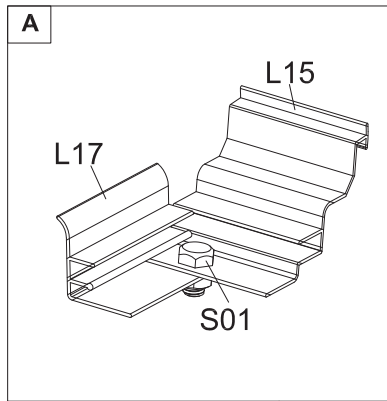

# Gruppo timpano anteriore

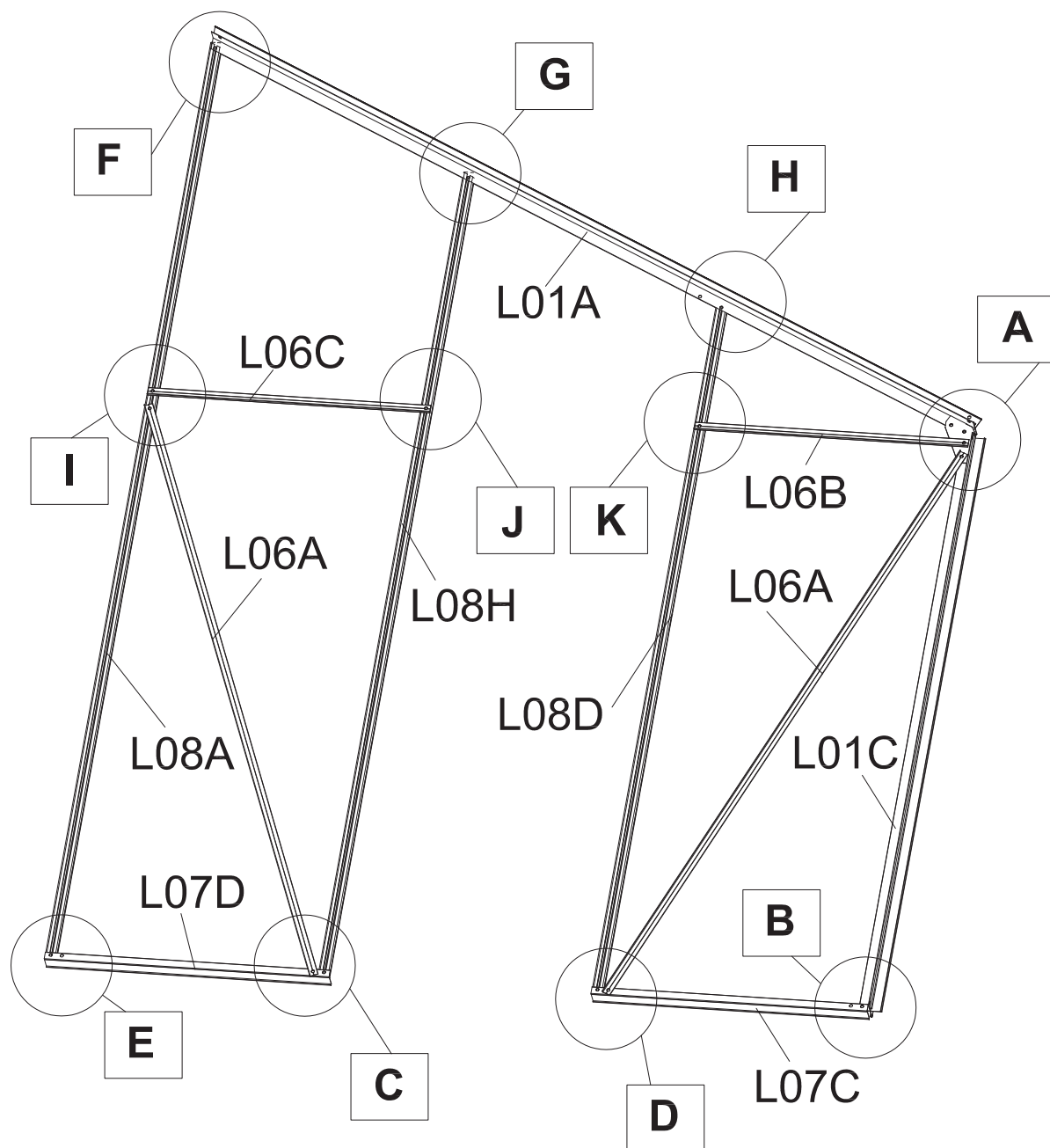

# Gruppo timpano anteriore

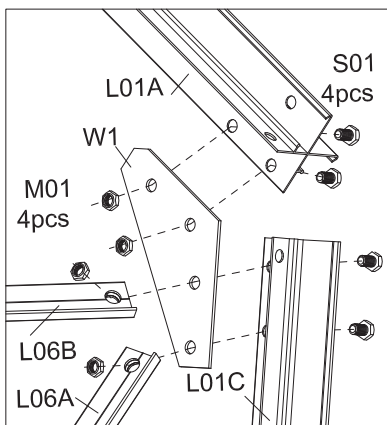

Non stringere i dadi prima di assemblare L09

**A**

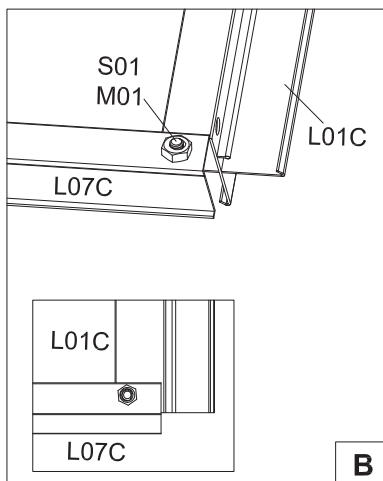

**B**

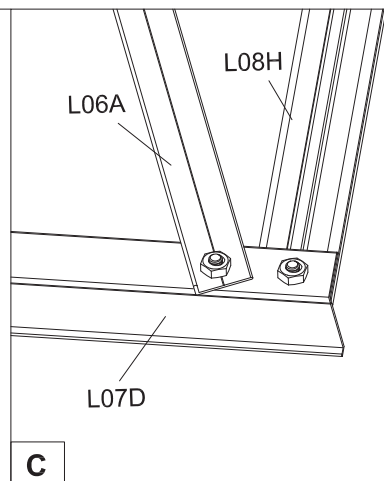

**C**

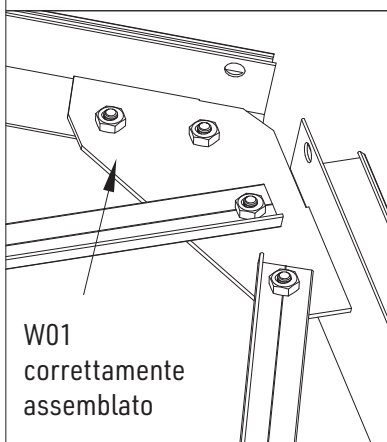

W01 correttamente assemblato

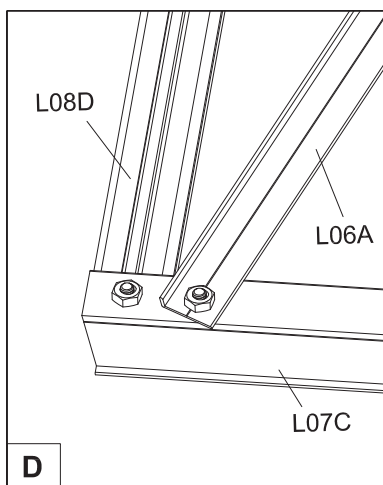

**D**

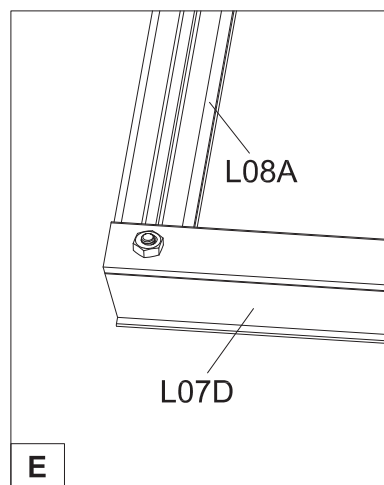

**E**

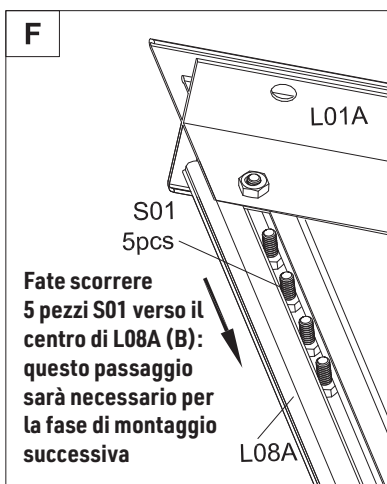

Fate scorrere 5 pezzi S01 verso il centro di L08A (B): questo passaggio sarà necessario per la fase di montaggio successiva

**F**

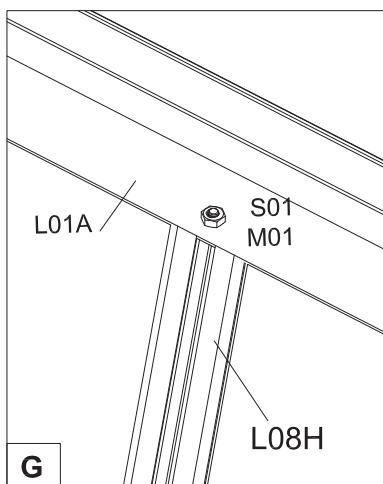

**G**

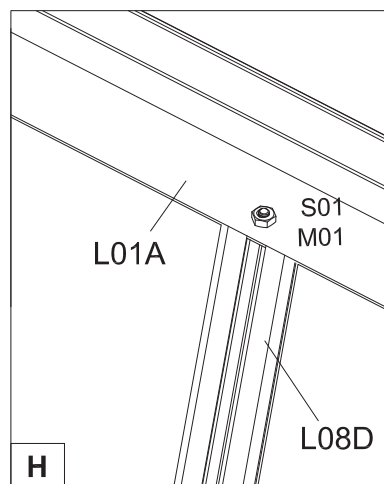

**H**

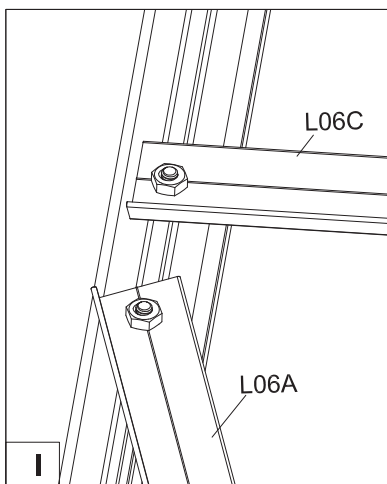

**I**

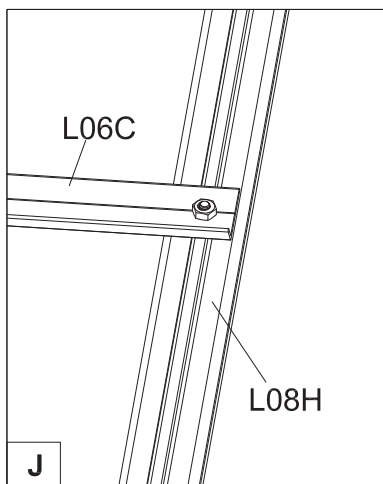

**J**

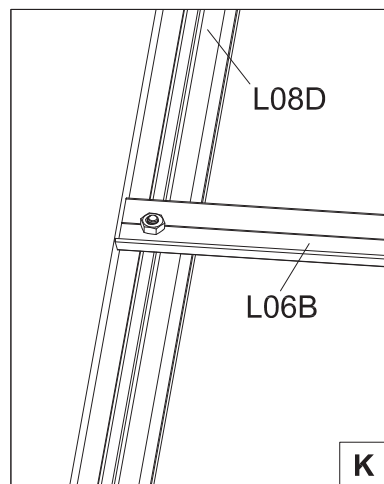

**K**



# Gruppo timpano anteriore

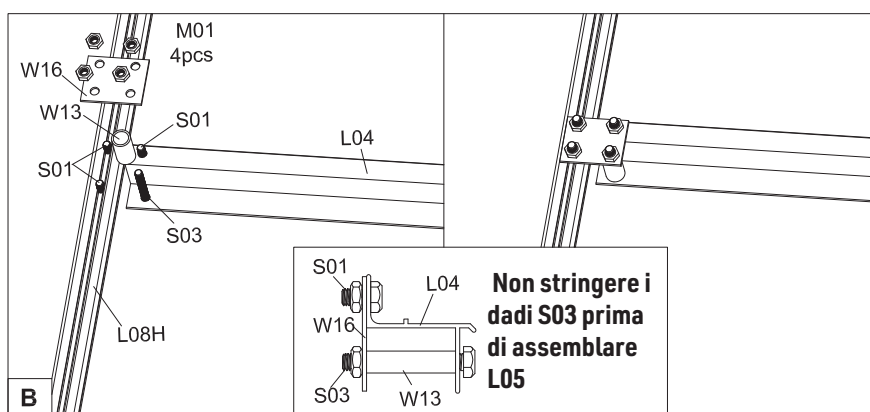
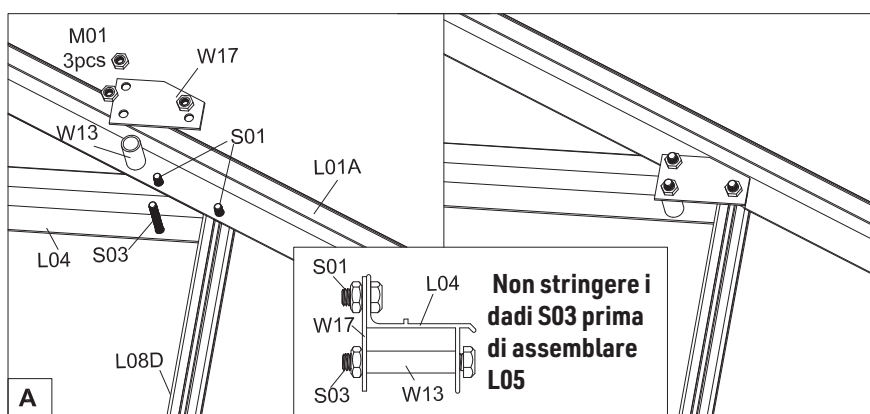
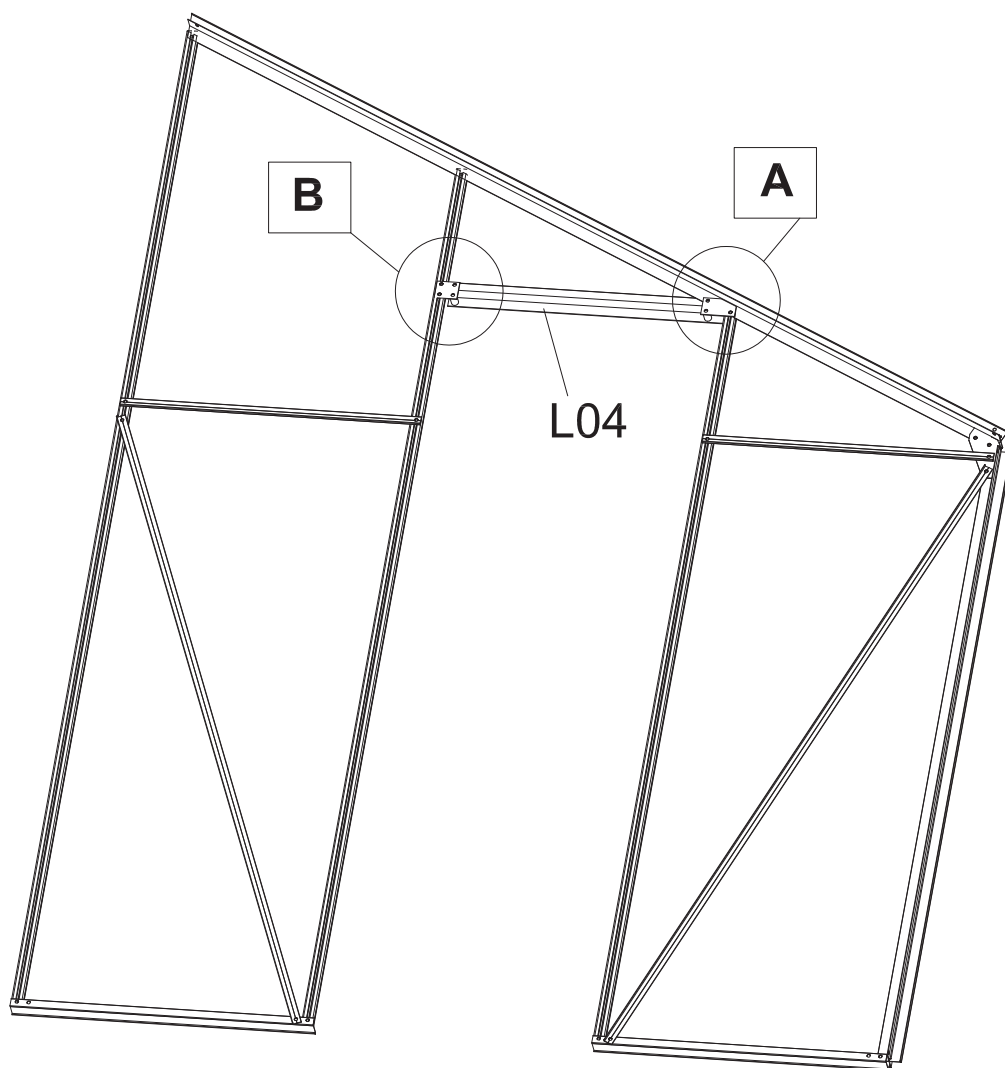

# Gruppo timpano posteriore

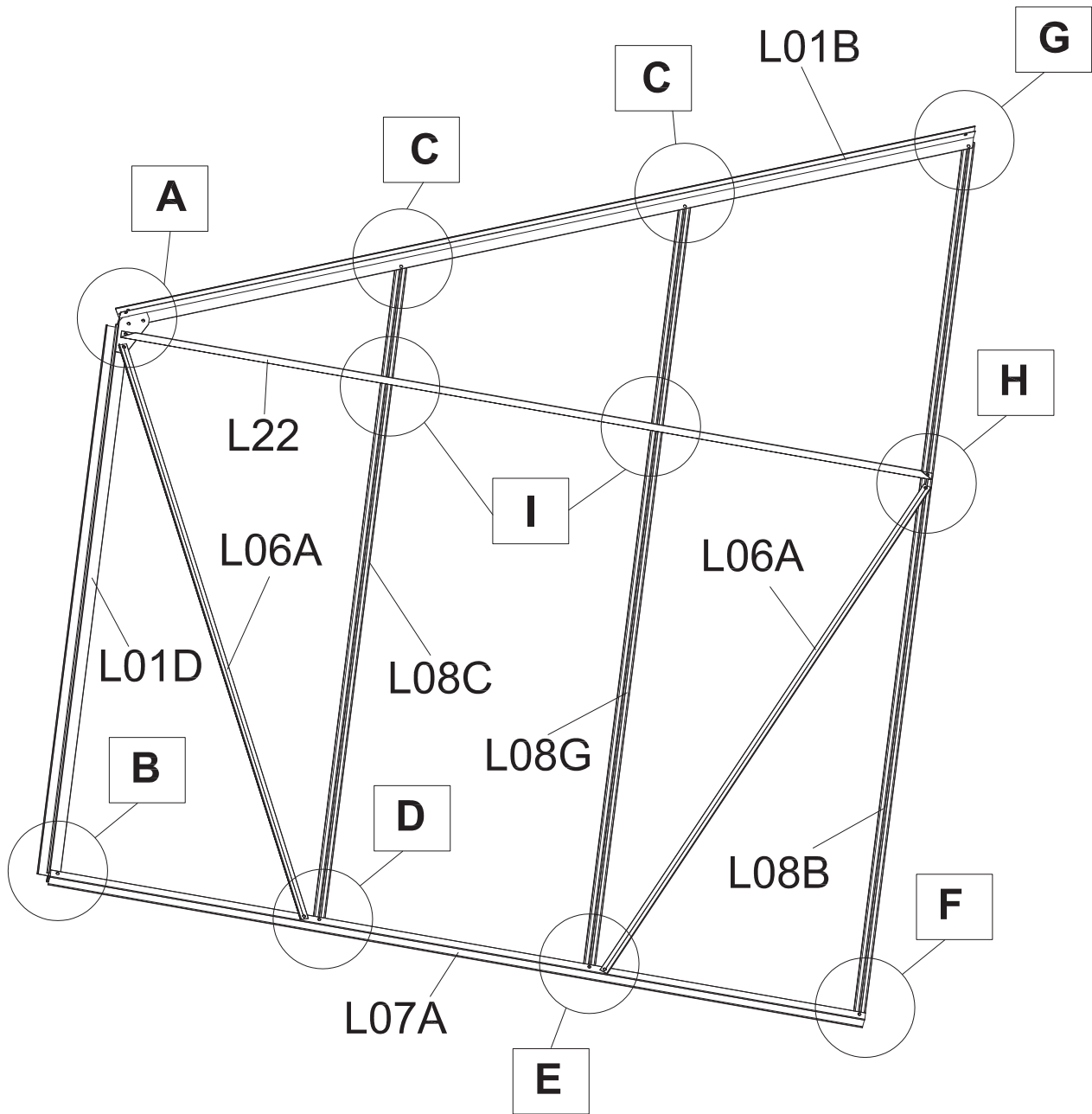

# Gruppo timpano posteriore

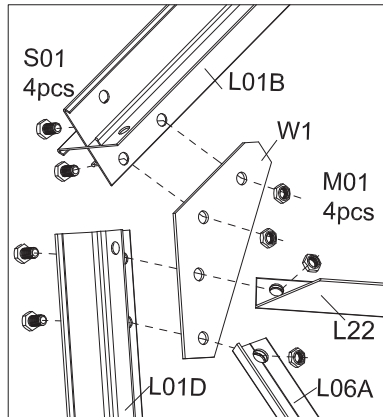

Non stringere i dadi S03 prima di assemblare L09

**A**

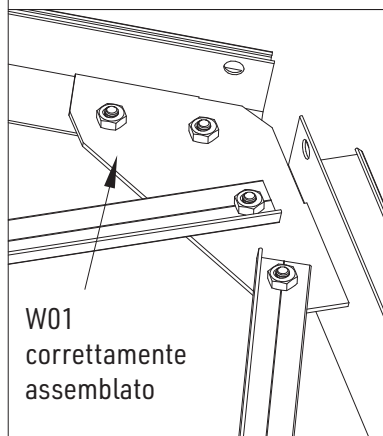

W01 correttamente assemblato

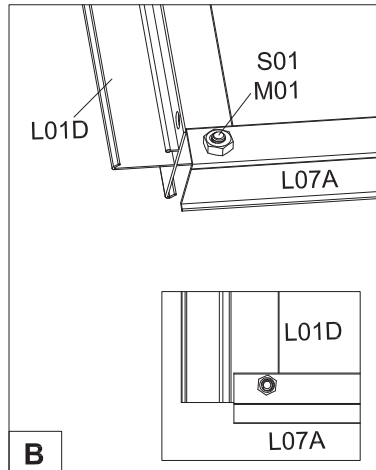

**B**

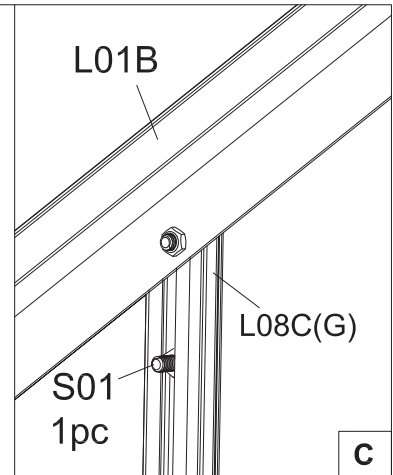

**C**

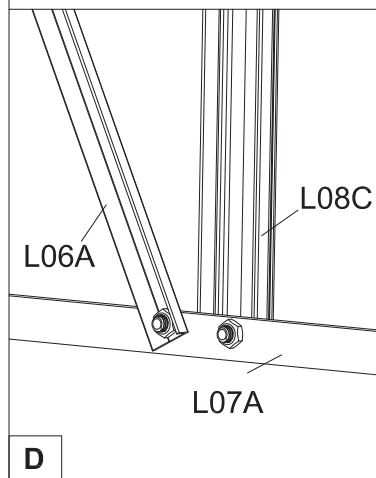

**D**

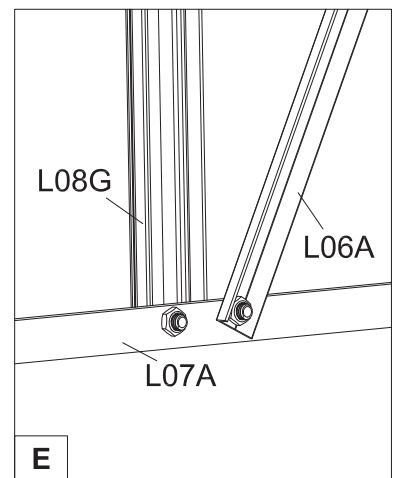

**E**

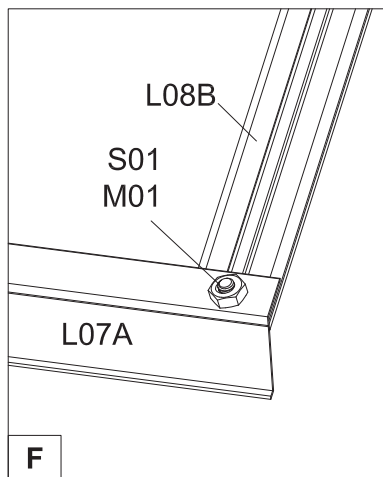

**F**

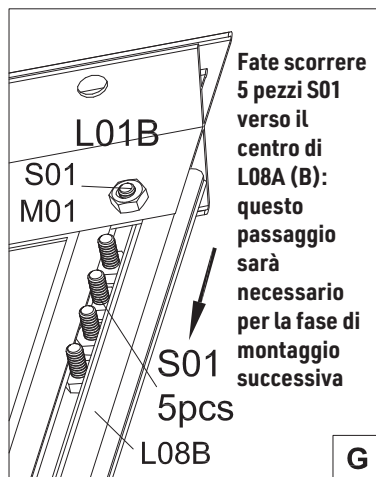

**G**

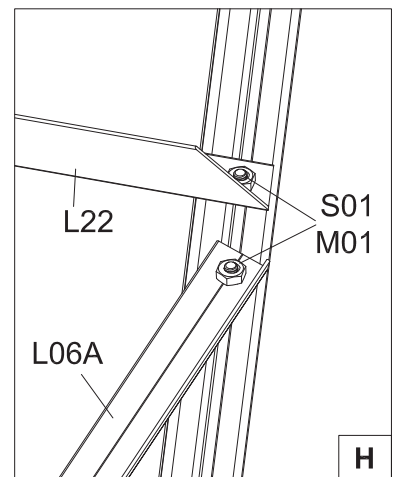

**H**

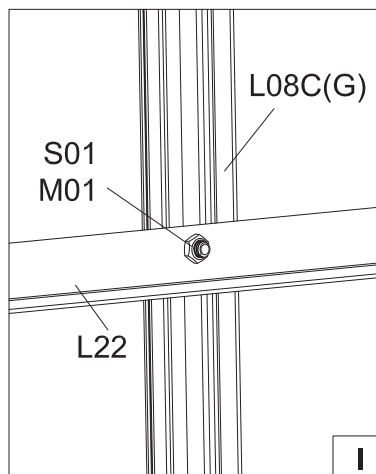

**I**



# Montaggio parete laterale

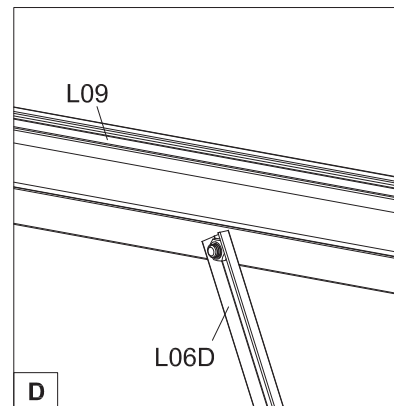
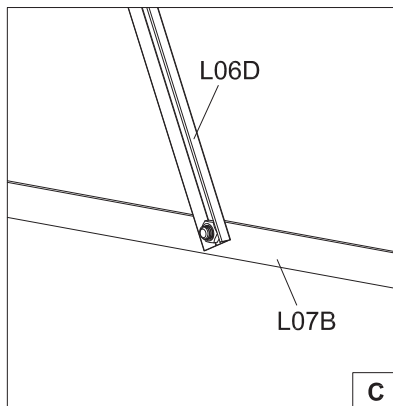
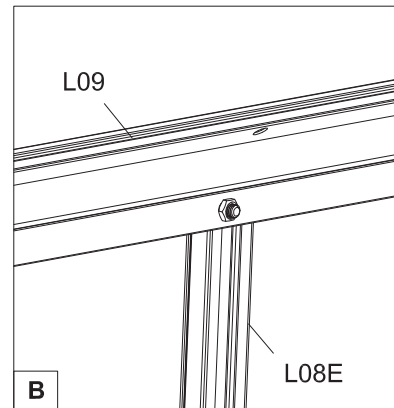
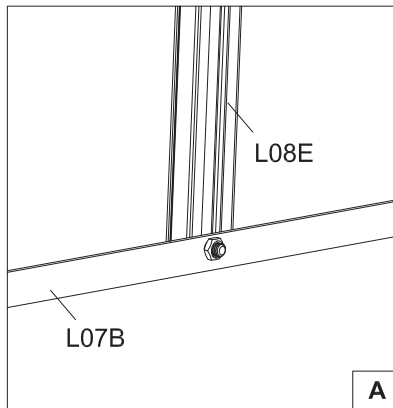
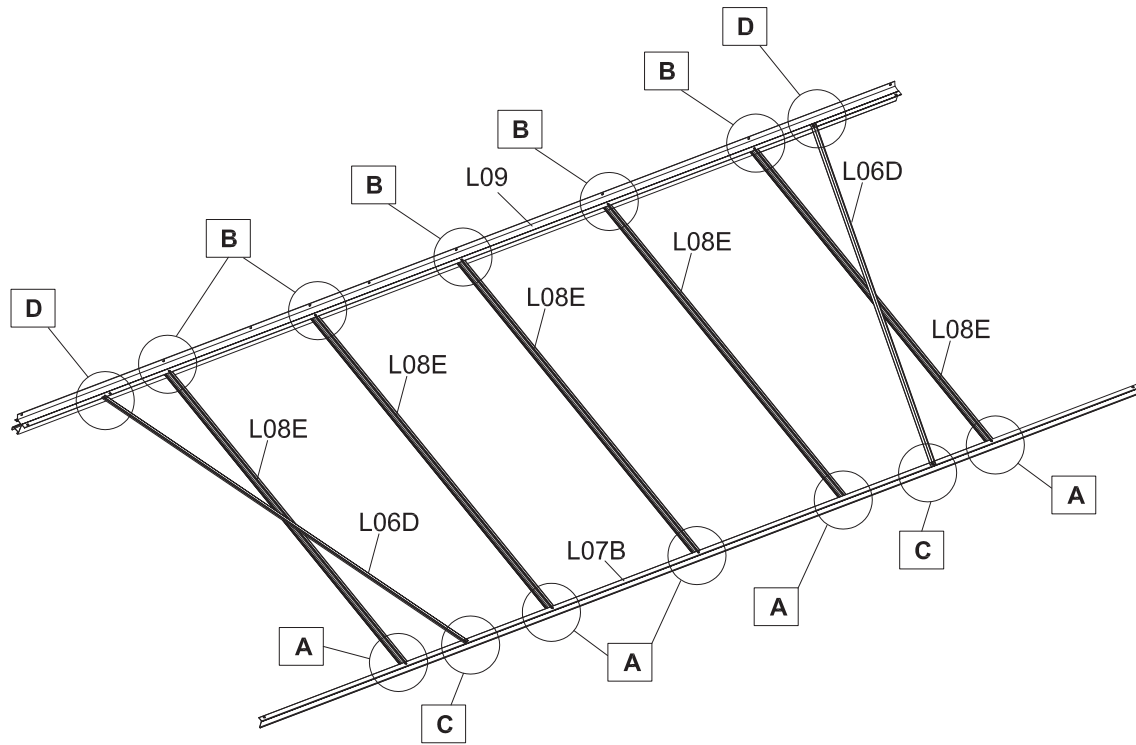

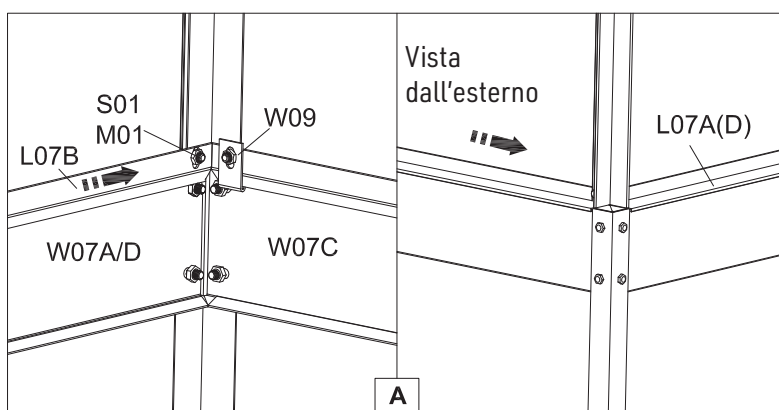
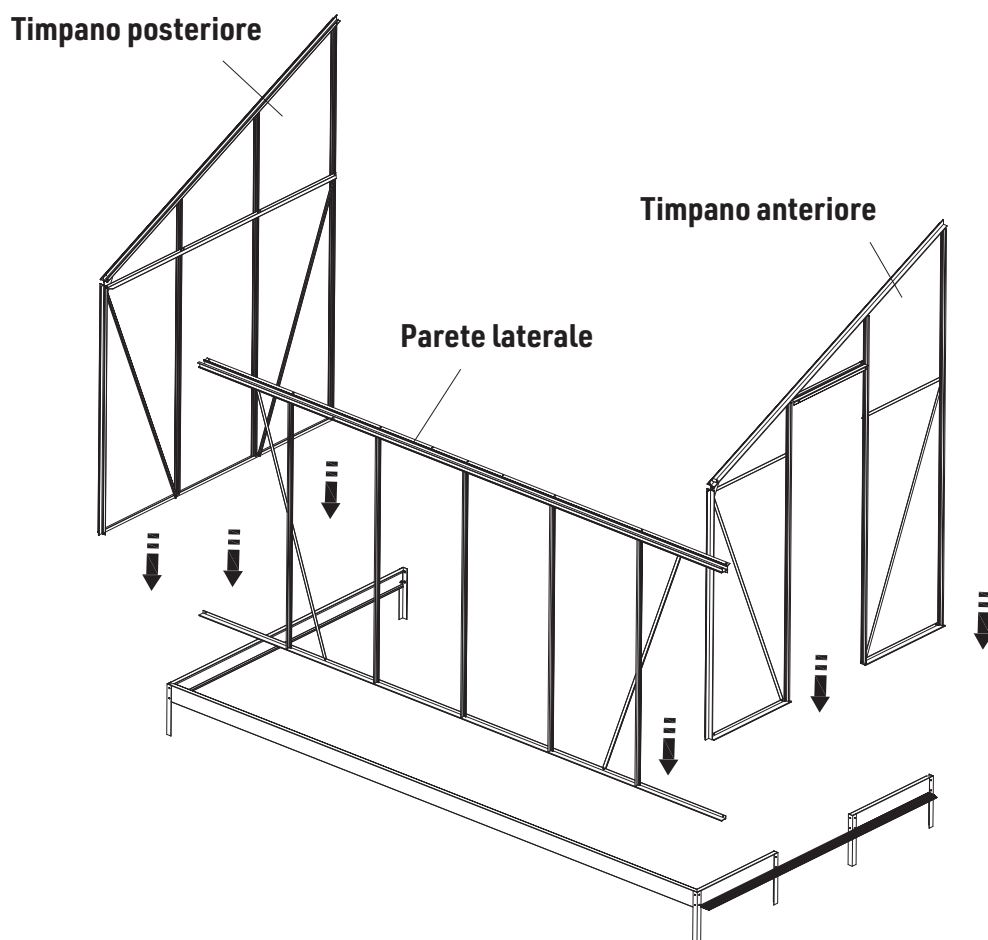

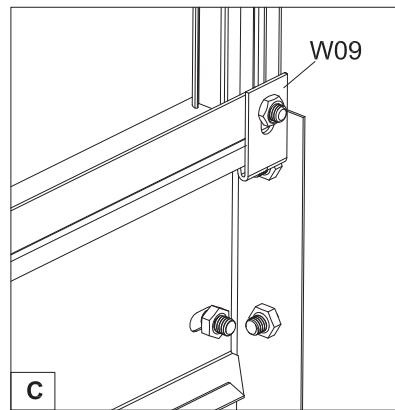
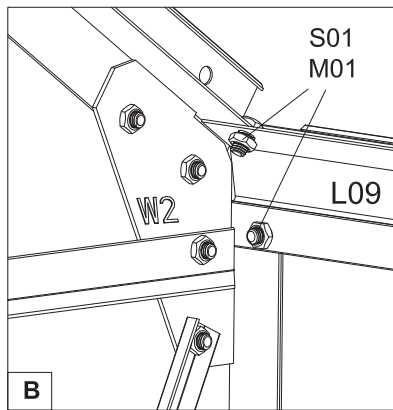
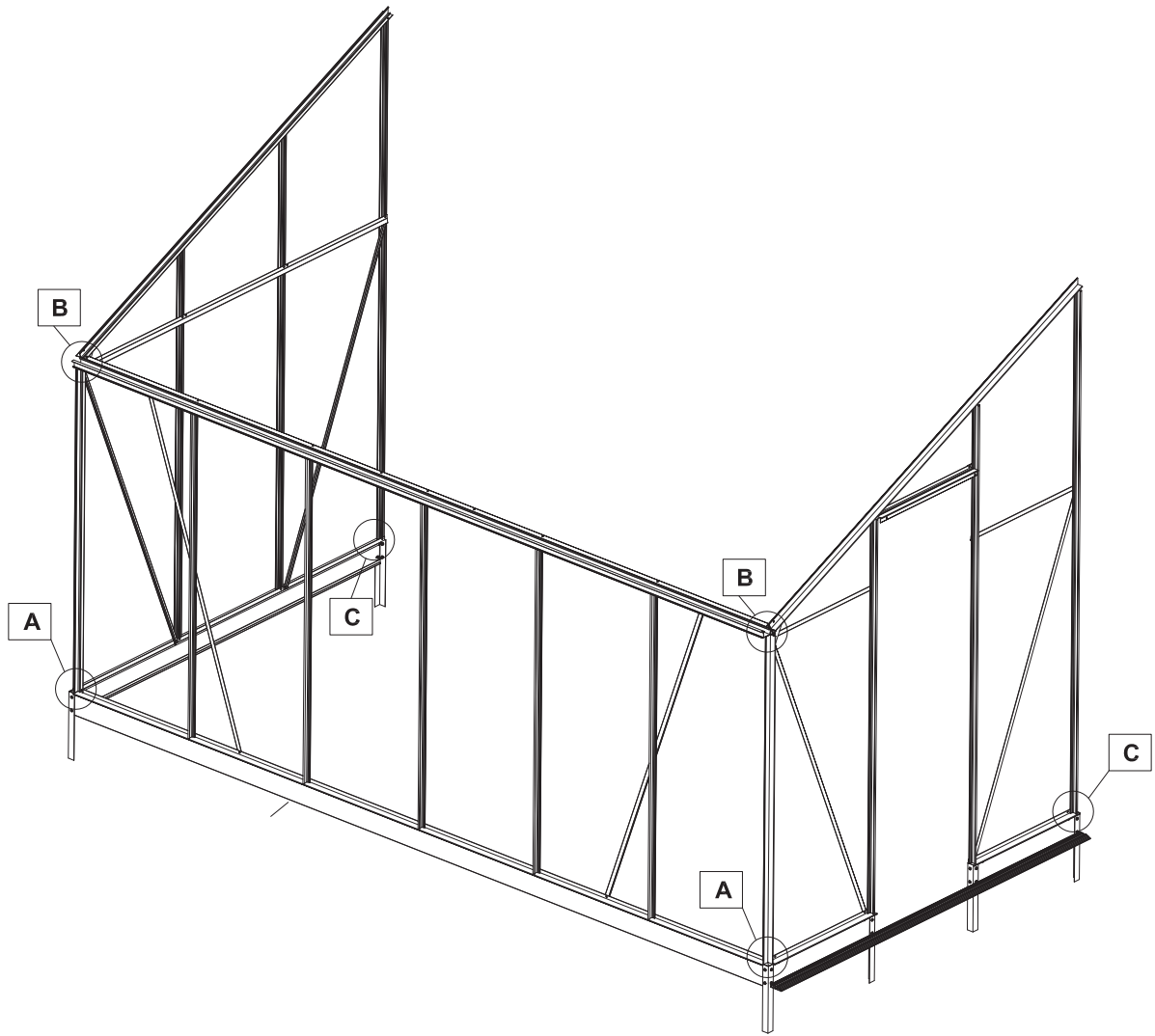

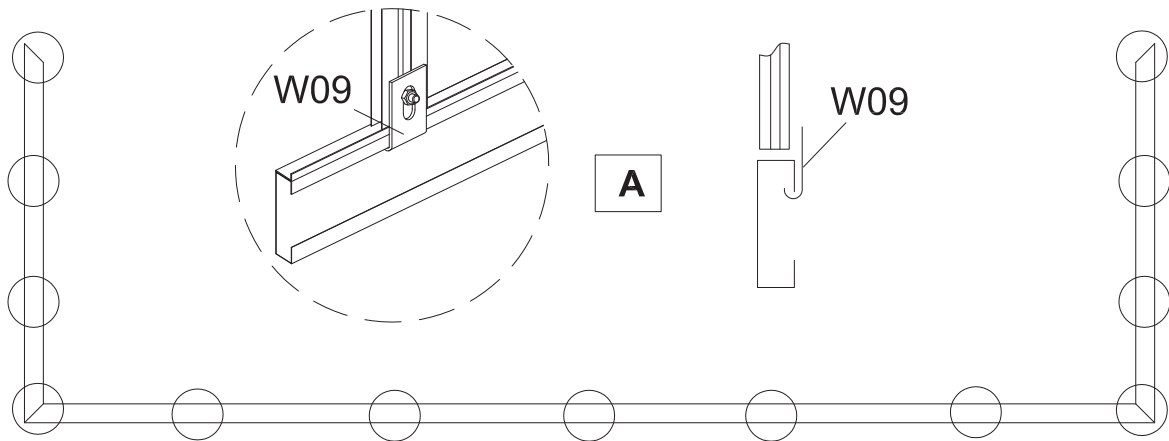
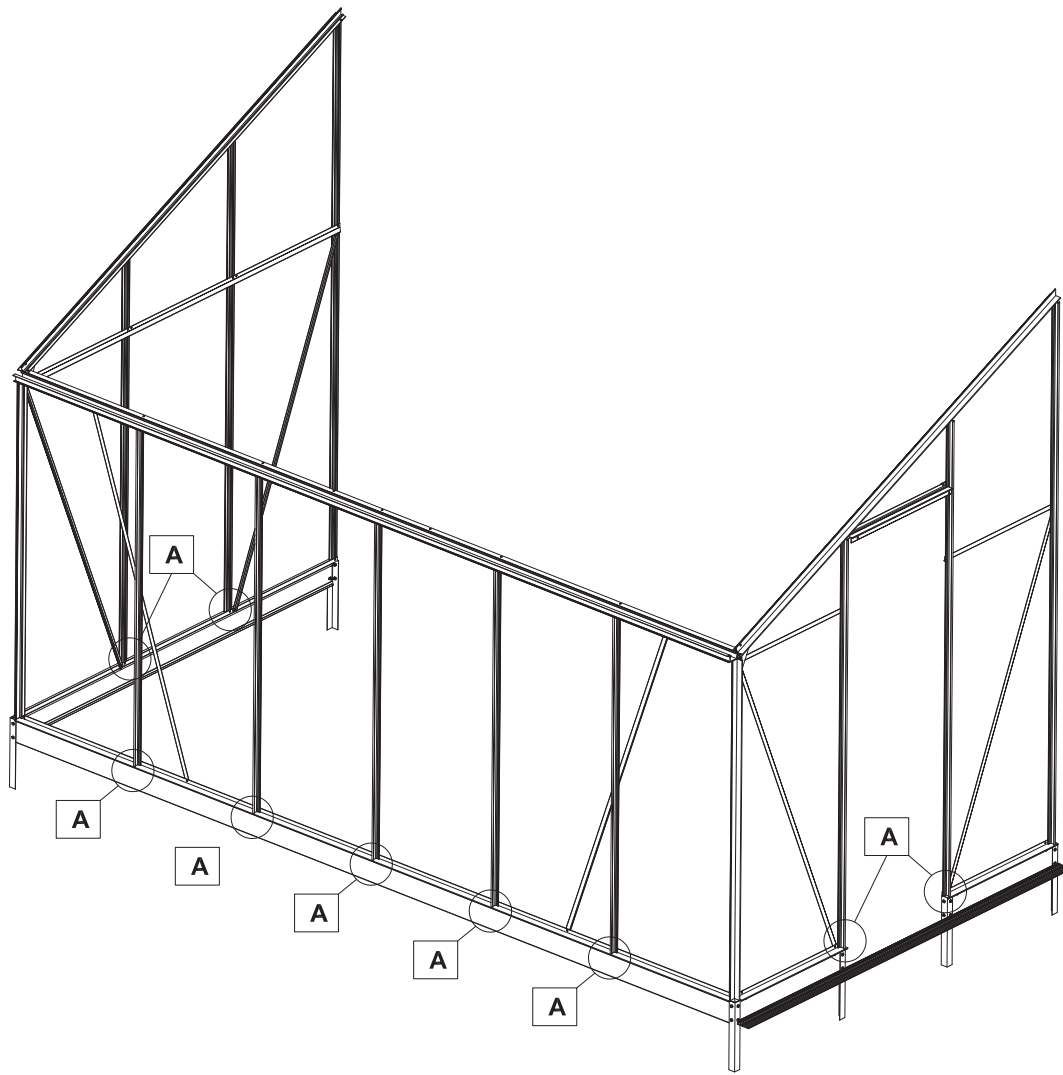

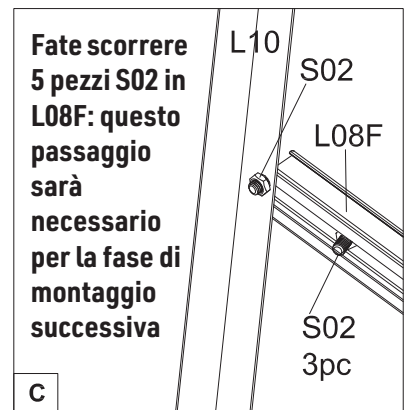
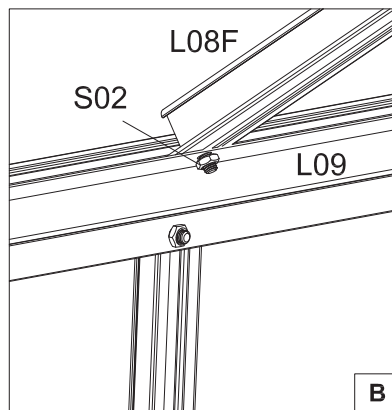
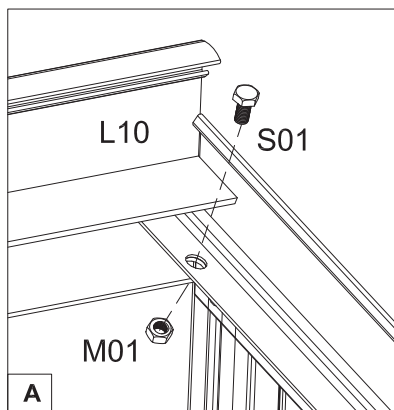
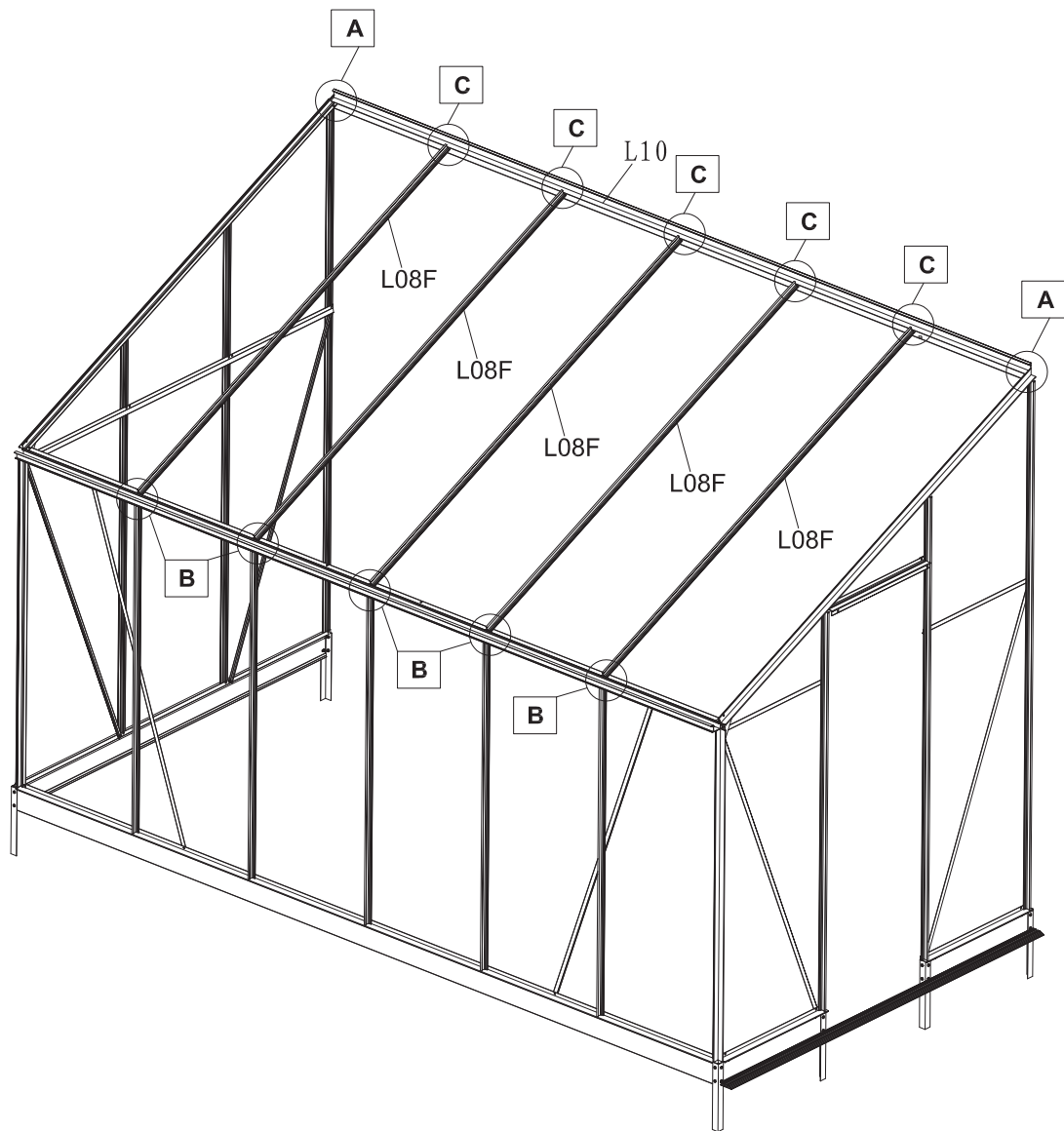

**Fate scorrere  
5 pezzi S02 in  
L08F: questo  
passaggio  
sarà  
necessario  
per la fase di  
montaggio  
successiva**

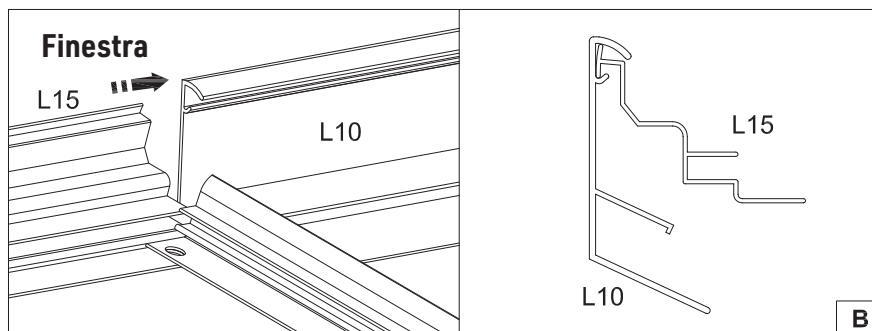
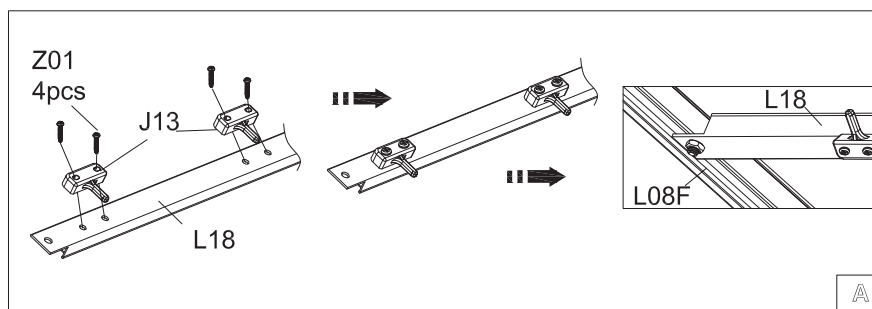
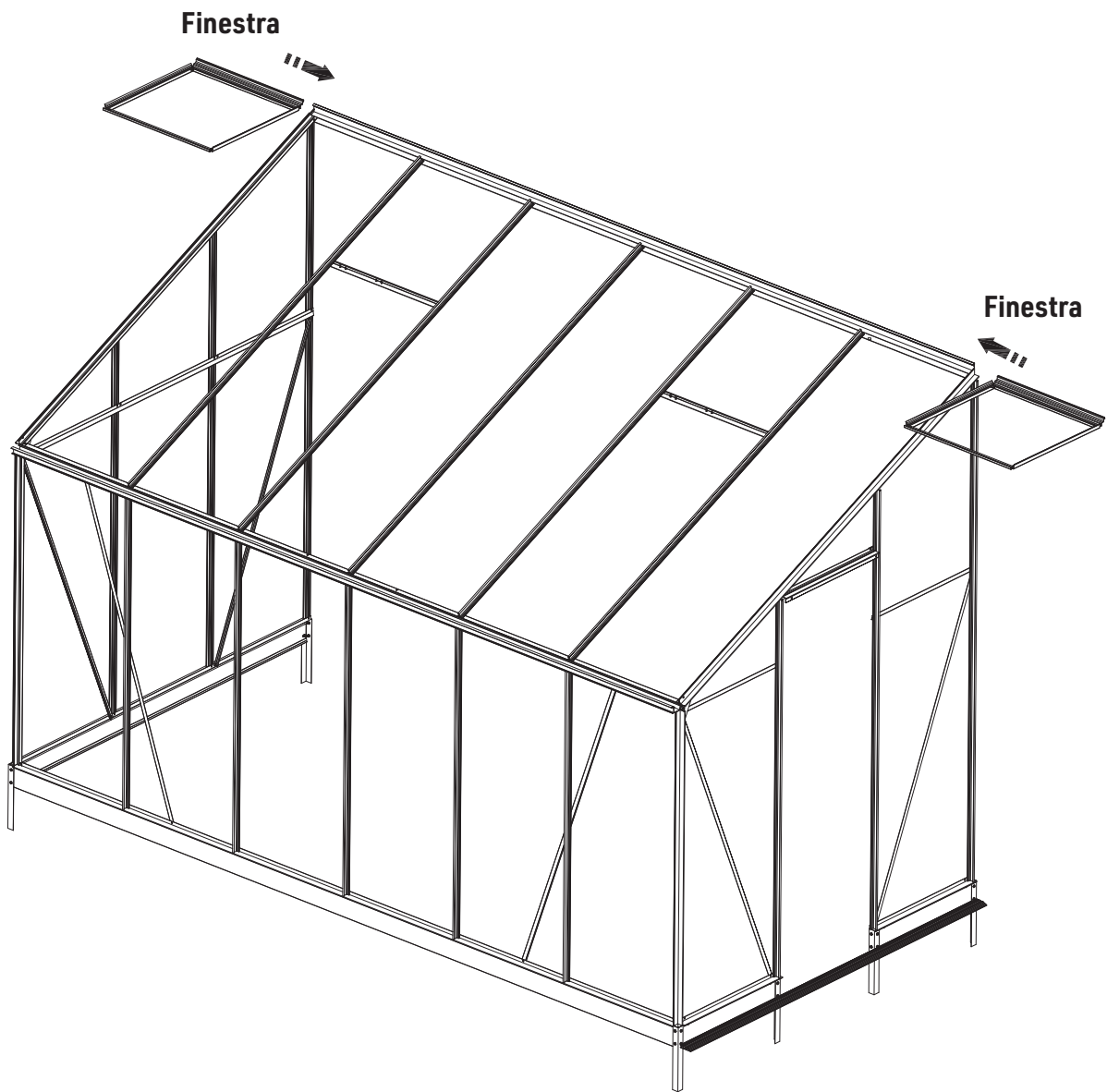

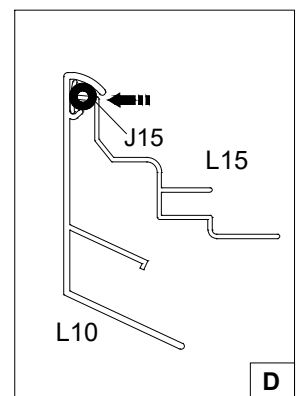
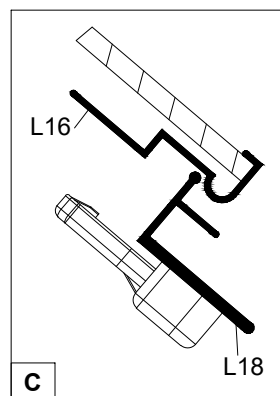
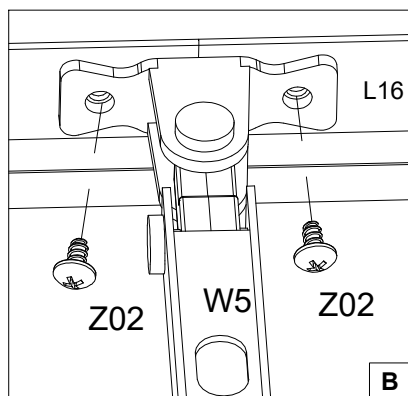
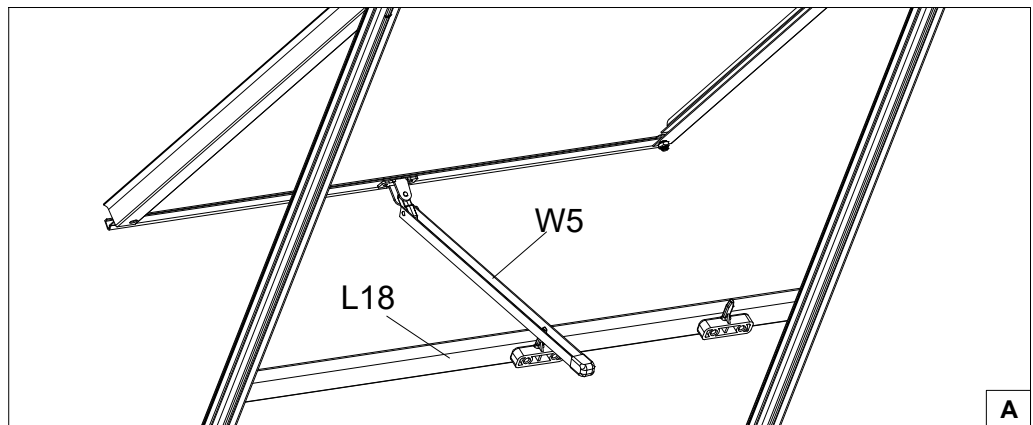
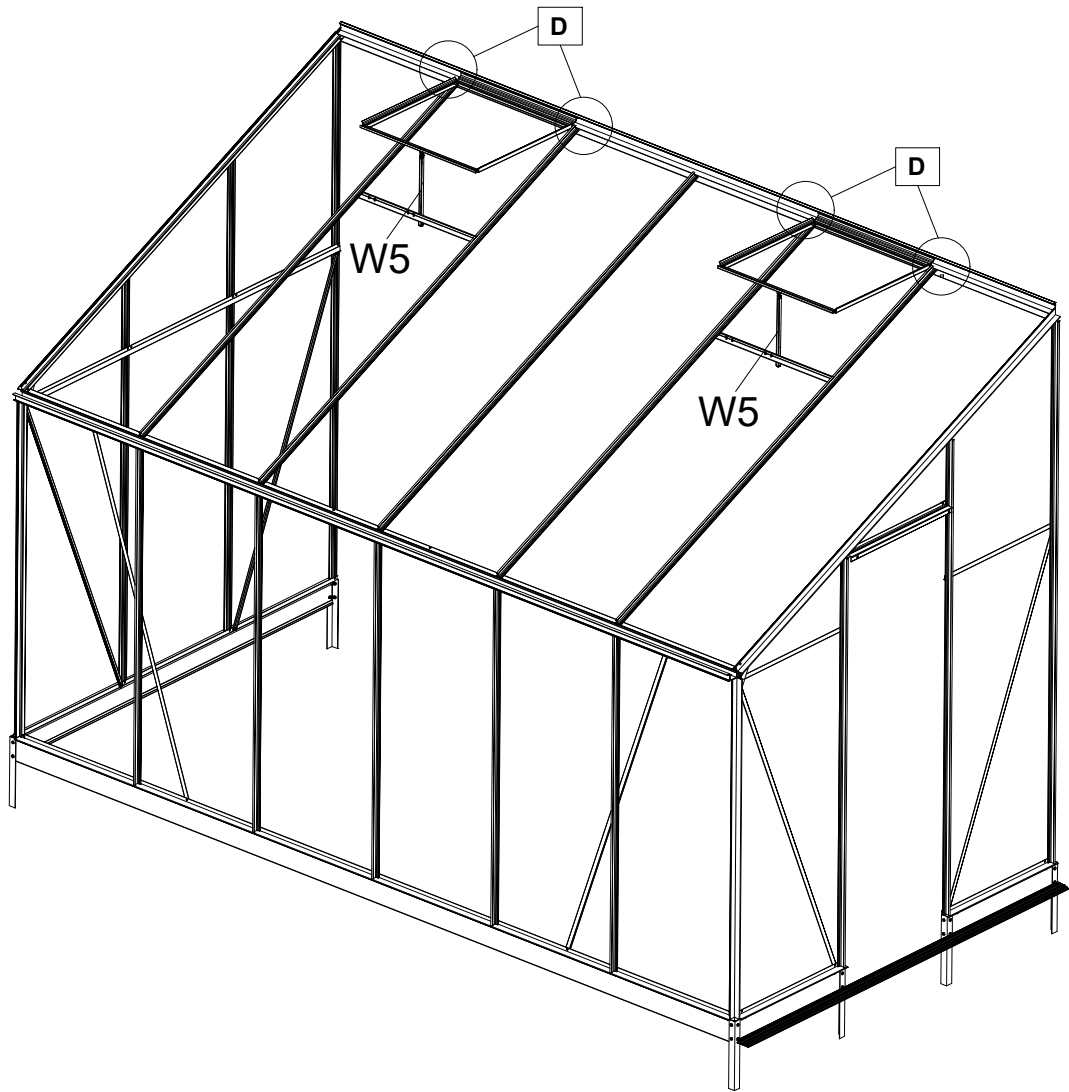

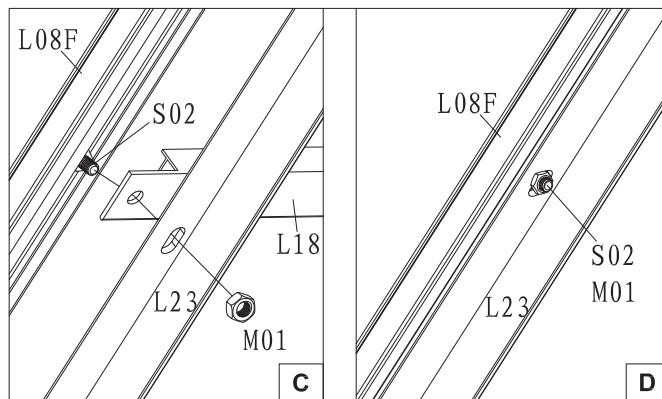
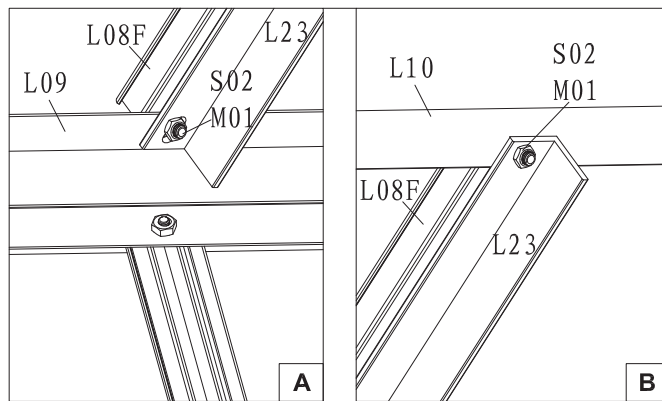
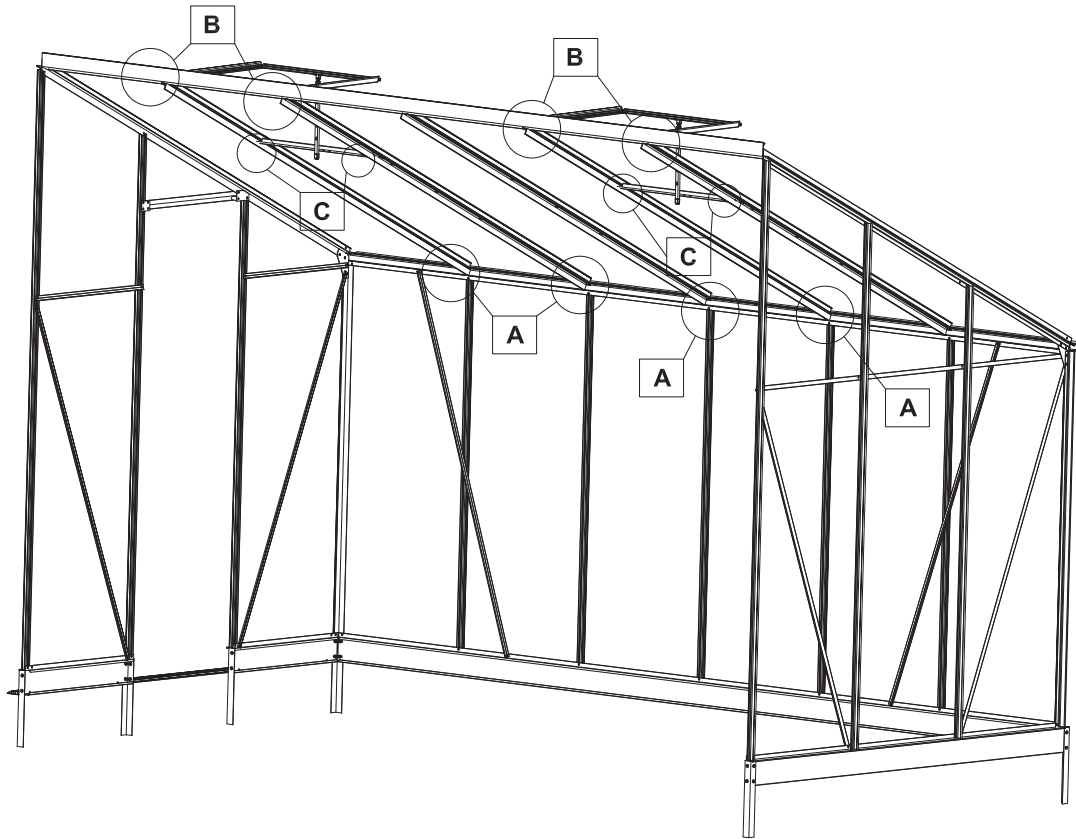

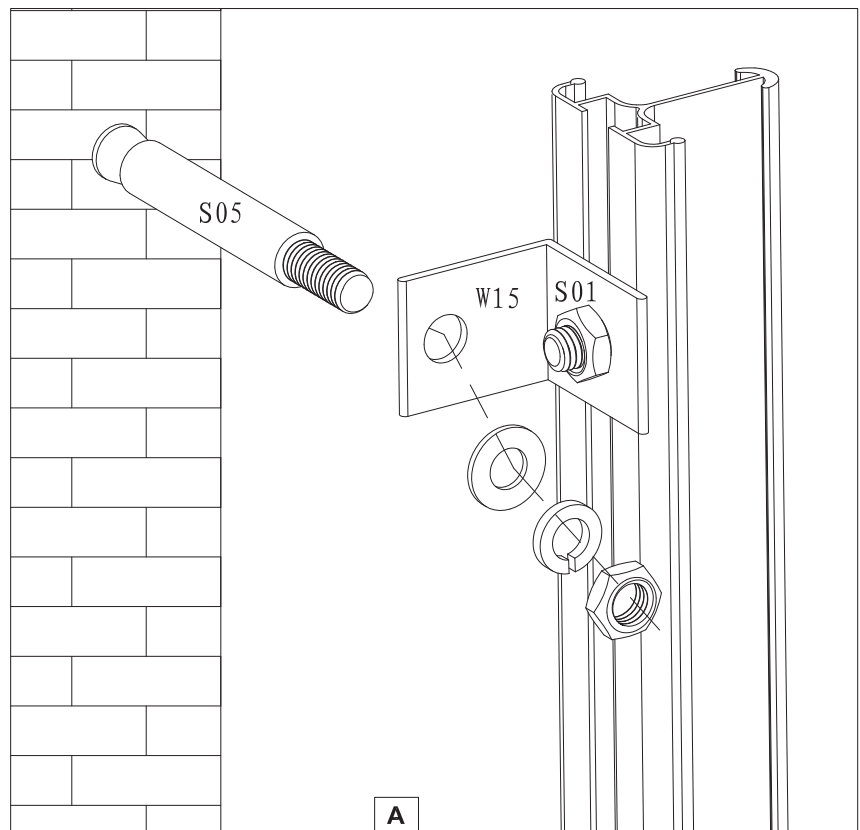
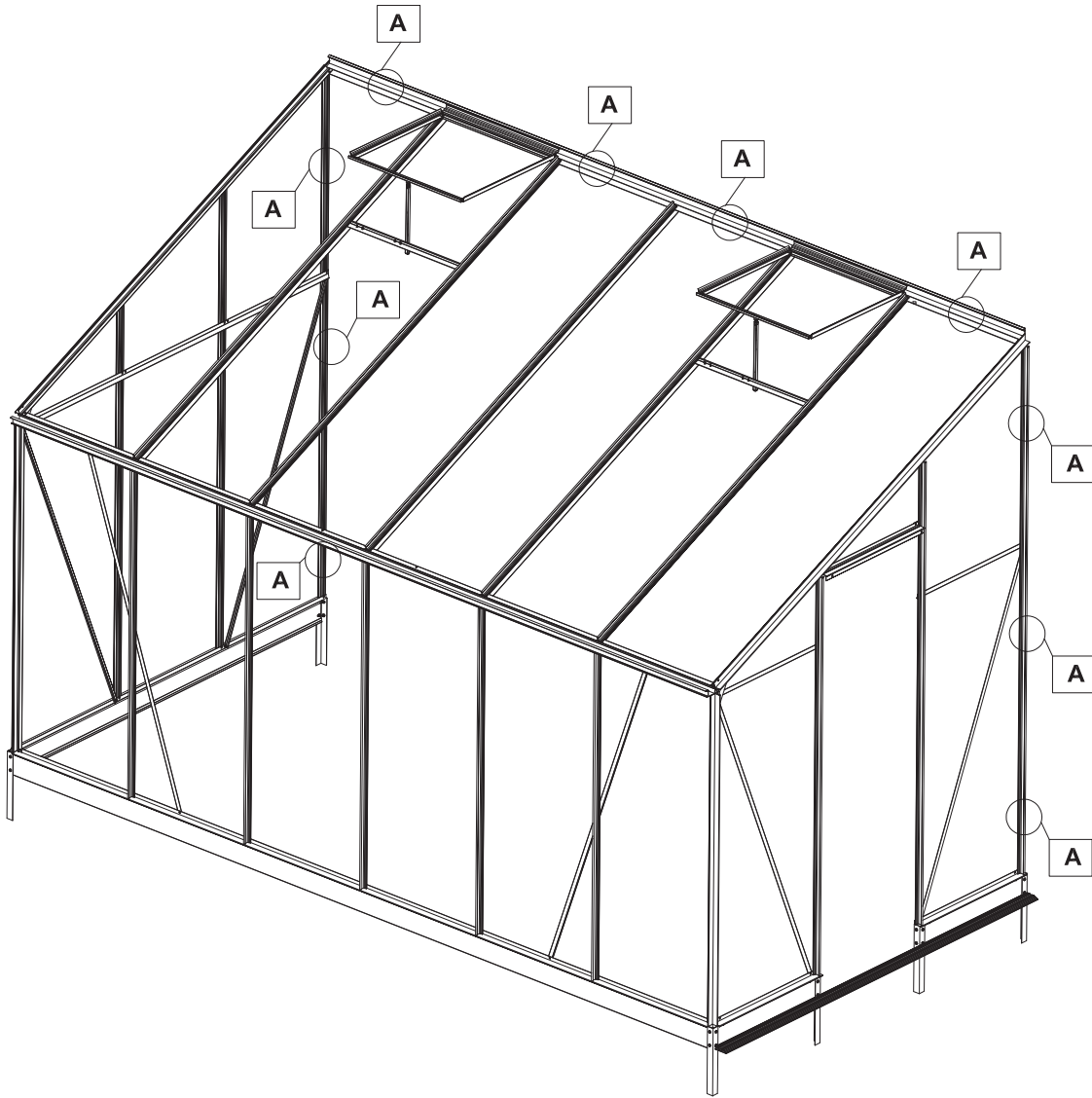

Inserimento della guarnizione in gomma J19

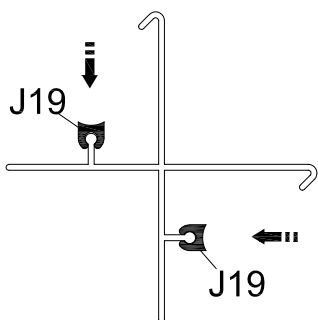

L01

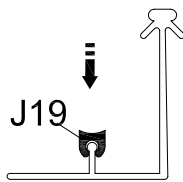

L03

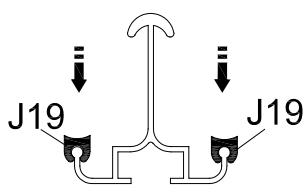

L08

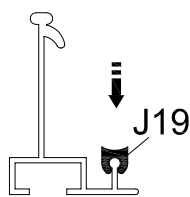

L11

Installazione delle vetrate

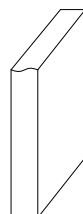
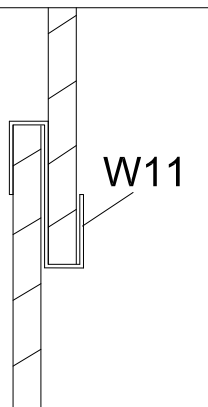
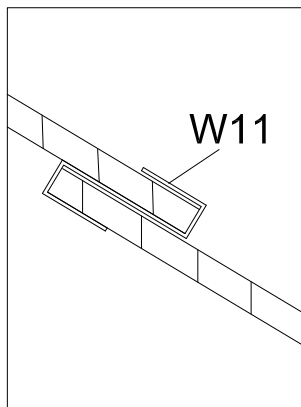
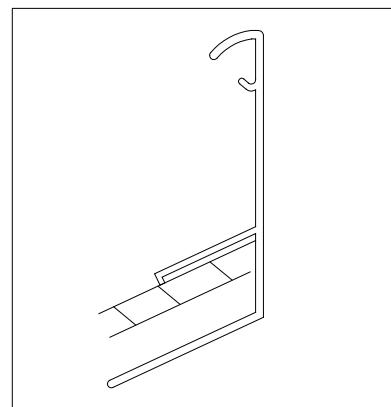
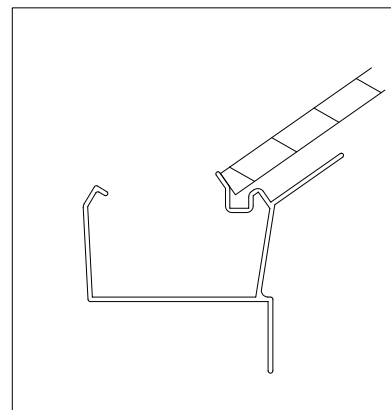

Fate attenzione a non ferirvi nel maneggiare e regolare le vetrate

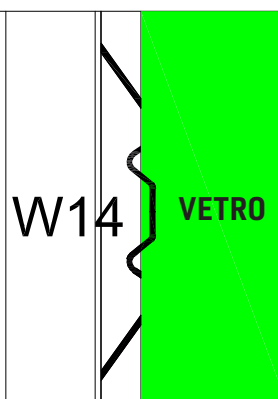
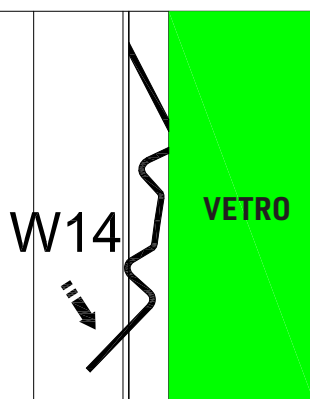
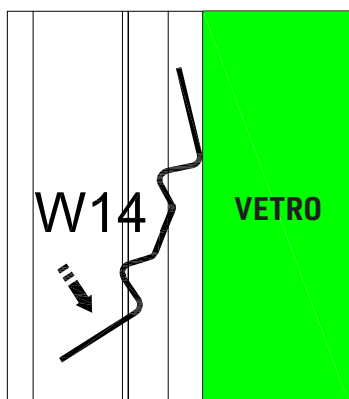
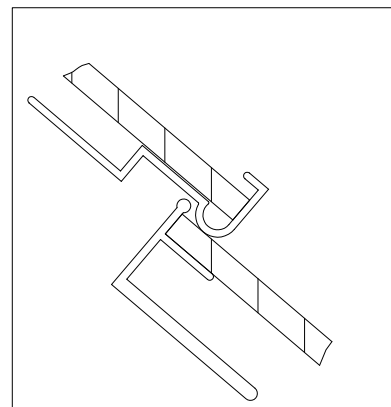

Fate attenzione a non ferirvi montando le clip W14

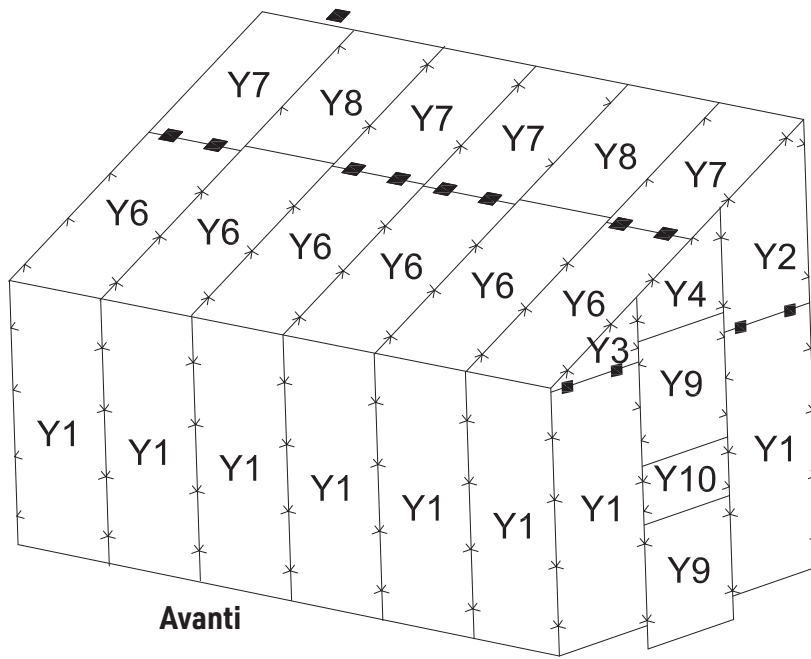

Avanti

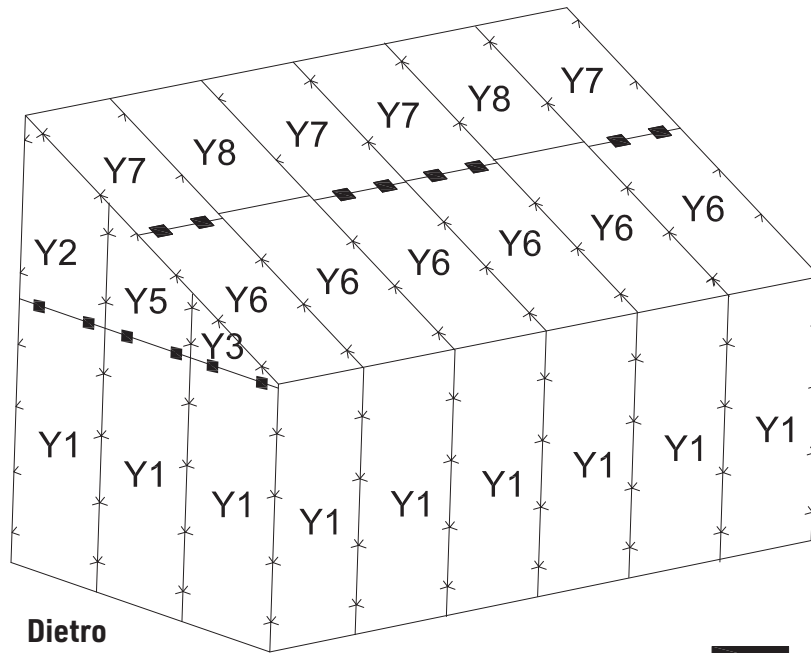

Dietro



Pezzi	Rif	mm	Qtà
	Y1	610x1472	11
	Y2	610x904x619	2
	Y3	610x326x41	2
	Y4	608x292x10	1
	Y5	610x616X330	1

Pezzi	Ref	mm	Qtà
	Y6	610x1338	6
	Y7	610x738	4
	Y8	602x726	2
	Y9	629x609	2
	Y10	629x395	1

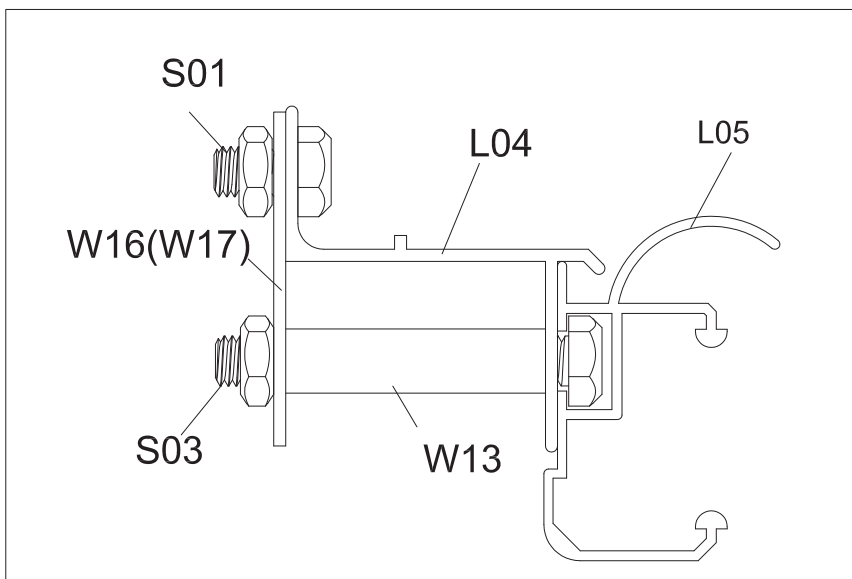
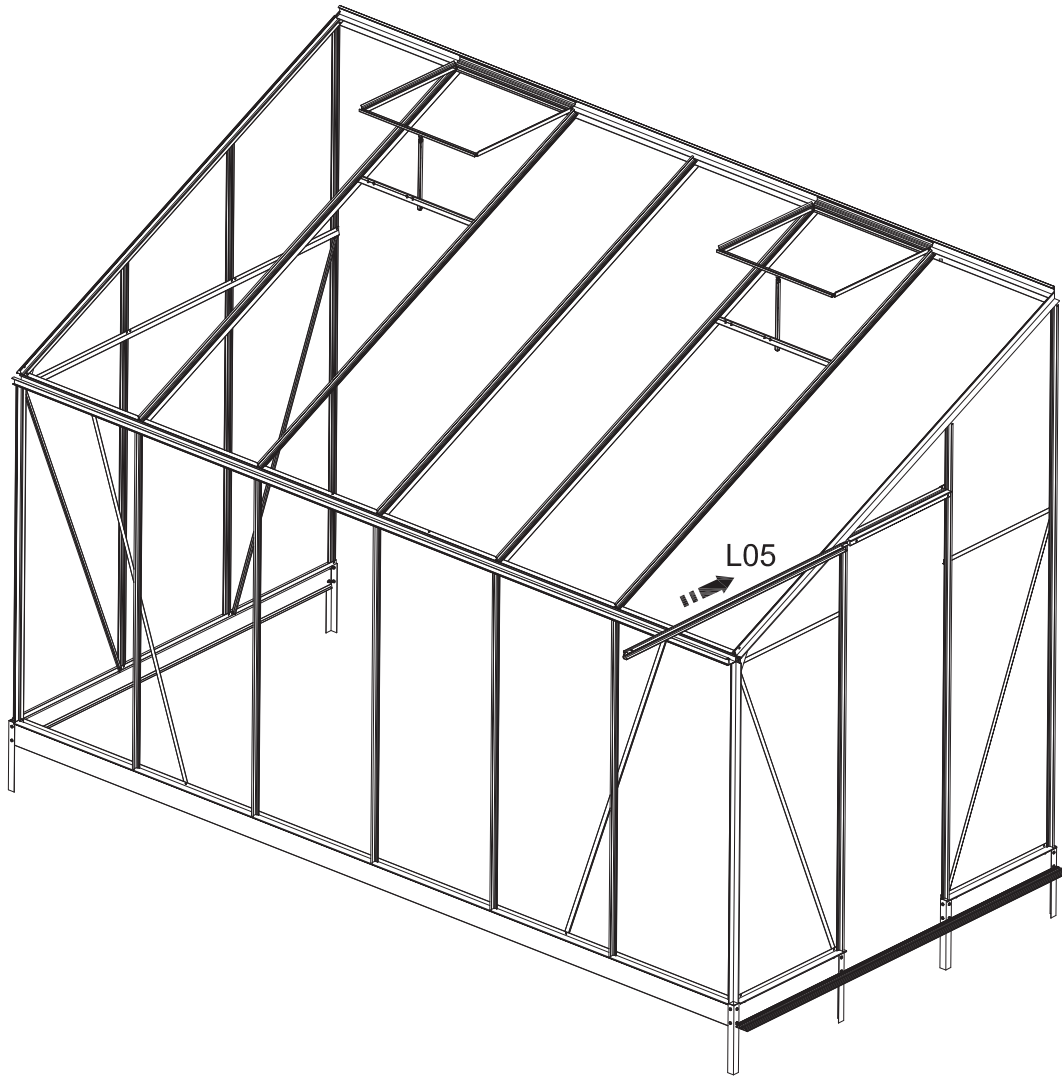

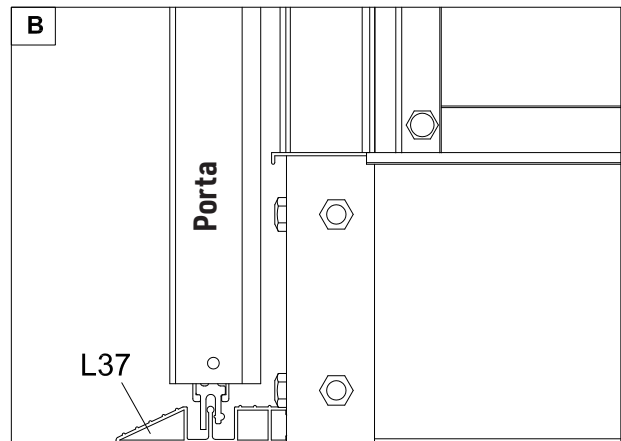
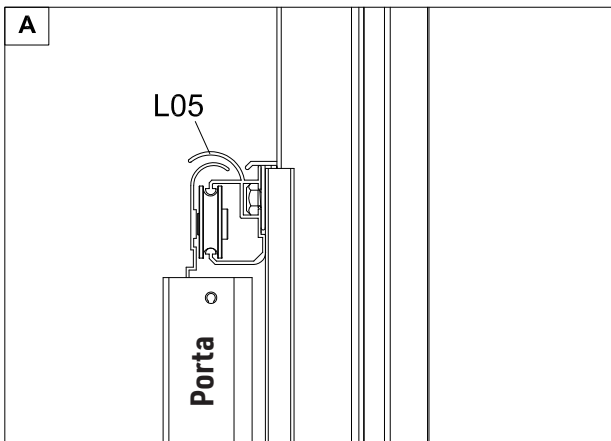
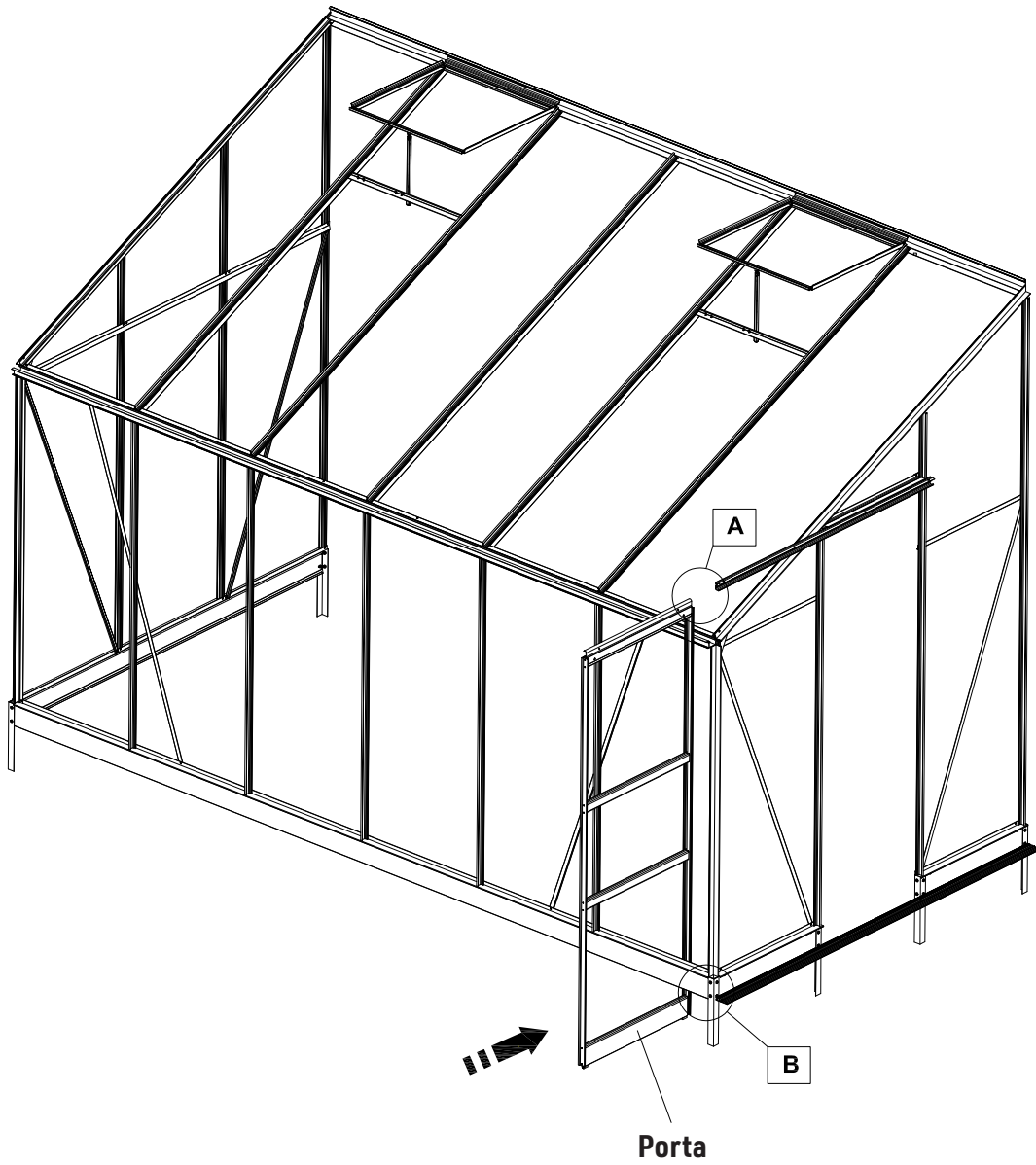

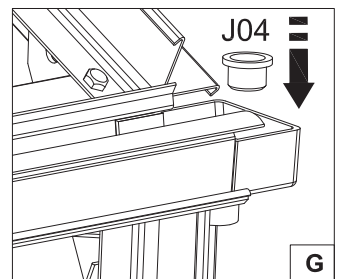
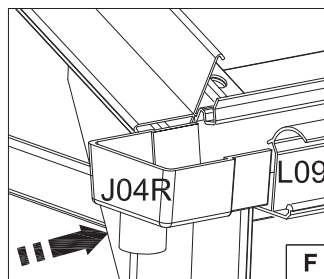
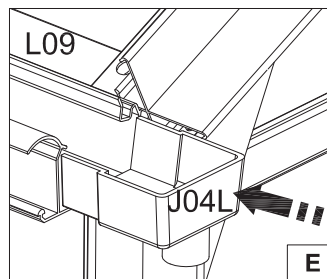
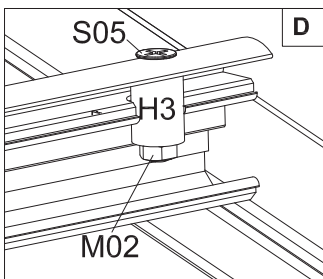
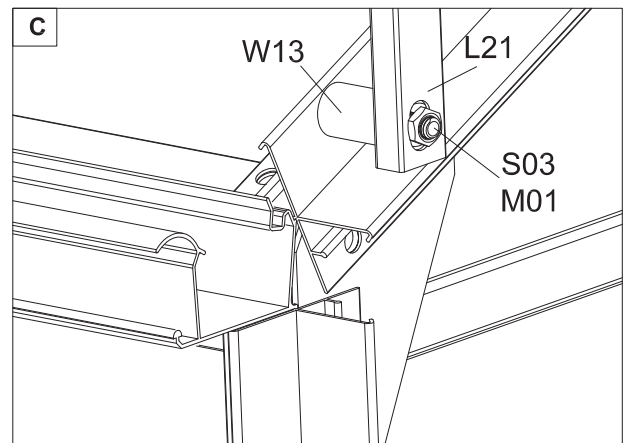
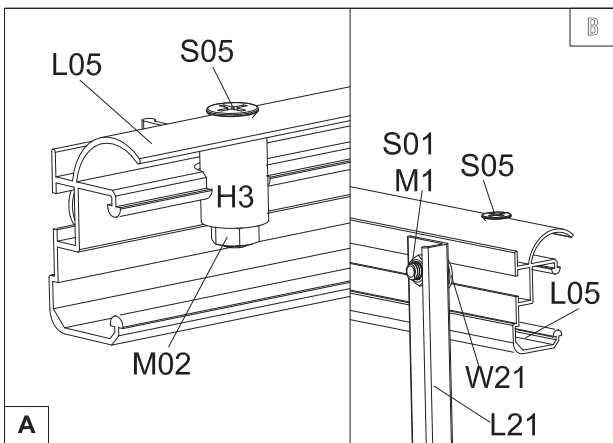
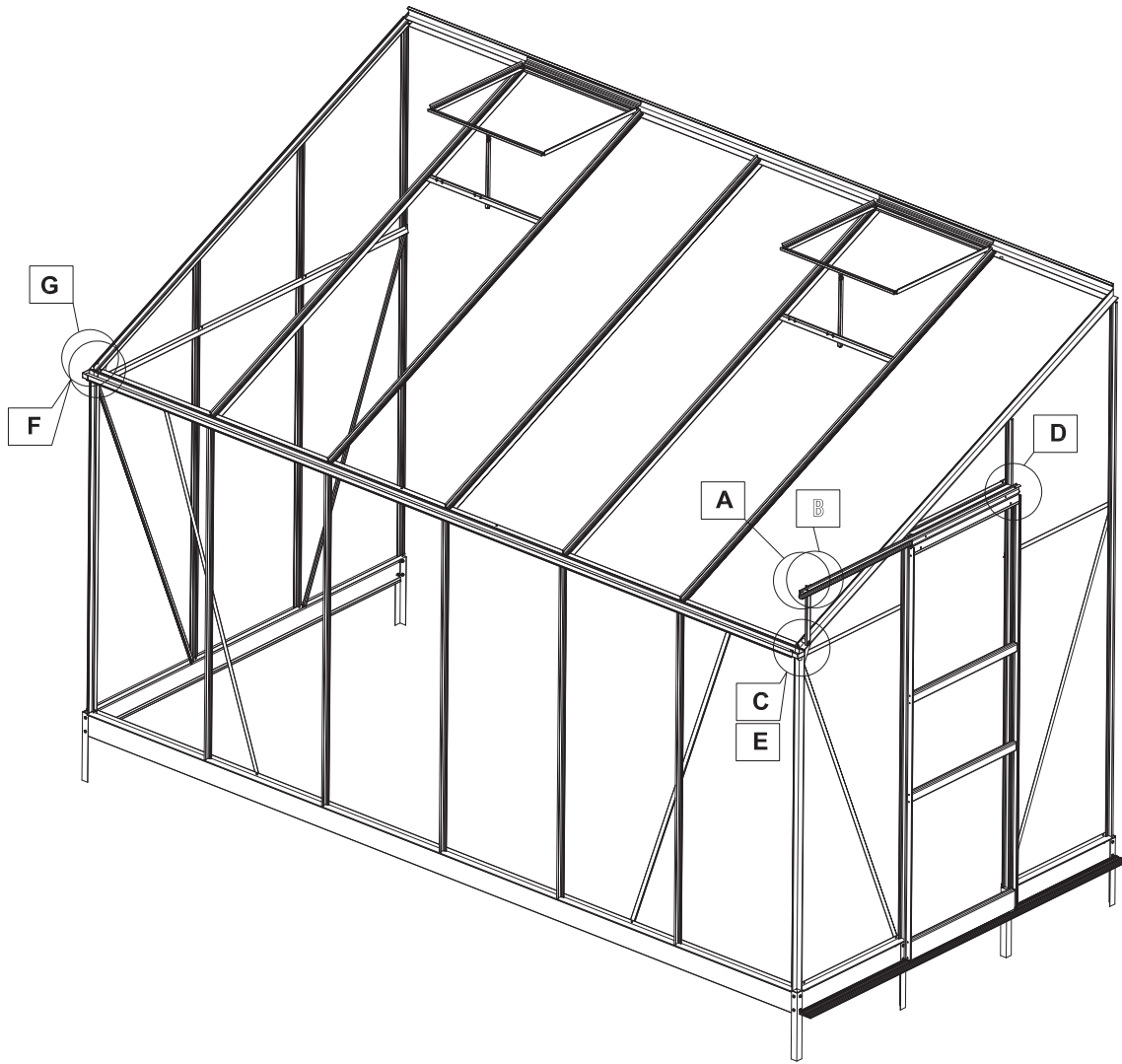

Szanowny Kliencie

Gratulujemy zakupu szklarni ogrodowej. Przed przystąpieniem do montażu prosimy o dokładne zapoznanie się z poniższą instrukcją montażu.

**Uwaga: przed rozpoczęciem montażu szklarni należy poświęcić odpowiednią ilość czasu na rozpoznanie wszystkich możliwych zagrożeń, takich jak wystające z ziemi kable bądź rury itp.**



### Miejsce montażu

- ☑ Słoneczne, otwarte, skierowane na północ miejsce, zabezpieczone przed silnymi wiatrami, jest najodpowiedniejszym miejscem do uzyskania najlepszych efektów w prowadzeniu upraw w szklarni.
- ☑ Szklarnia powinna być ustawiona na płaskim, równym podłożu. Istnieje kilka opcji przygotowania fundamentu pod szklarnię, które można dostosować do swoich potrzeb. Szklarnie są dostarczane z podstawą, która ułatwia montaż i pozwala na przymocowanie szklarni do podłoża.
- ☑ Dostęp do wody i gniazdek elektrycznych z prądem powinien być brany pod uwagę na wczesnym etapie montażu, jeszcze przed położeniem solidnych fundamentów.
- ☑ Zaleca się zapewnienie wystarczającego przejścia wokół szklarni, zarówno podczas instalacji, jak i przy późniejszej konserwacji.

### Konfiguracja





- ☑ Zmontować ramę aluminiową (bez szyby) i ustawić ją w miejscu montażu, aby można było wykopać otwory pod fundamenty. Pozwoli to na zlokalizowanie i zaznaczenie dokładnej pozycji otworów pod słupki do zakotwienia.
- ☑ Po zaznaczeniu pozycji kotew należy przesunąć ramę szklarni, aby umożliwić wykopanie otworów.
- ☑ Zalecana jest minimalna głębokość 60 cm i średnica 20 cm. Po przymocowaniu kotw mocujących do podstawy i wsporników, można podnieść ramę szklarni i umieścić nad otworami poprzez opuszczenie jej do poziomu gruntu.
- ☑ Po zaakceptowaniu ostatecznego położenia i upewnieniu się, że rama jest płaska i prostopadła i ułożona równomiernie, można przystąpić do zalewania otworów betonem i tym samym przymocować szklarnię trwale do gruntu.





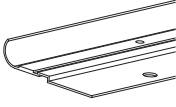
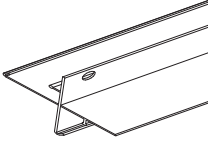
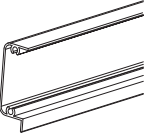
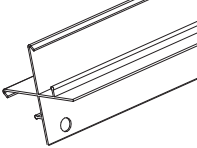
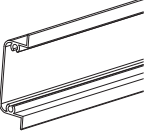
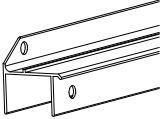
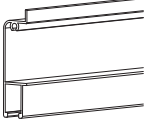
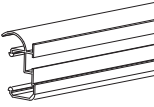
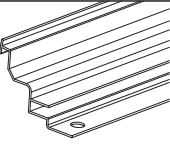
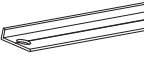
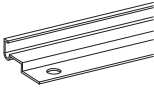
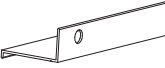
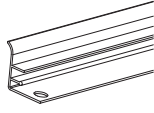
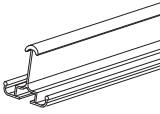
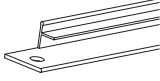
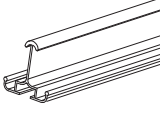
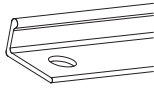
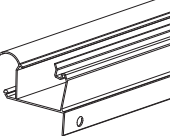
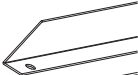
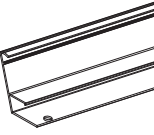

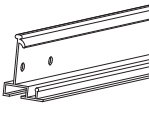



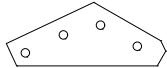

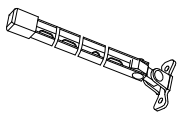





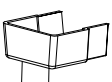



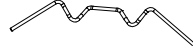
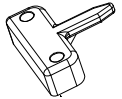



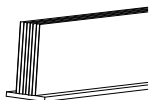

### Mocowanie do solidnej podstawy

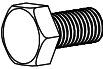
- ☑ Zalecamy skorzystanie z planu podstawy dołączonego do instrukcji montażowej jako wskazówki do przygotowania solidnej podstawy, niezależnie od tego, czy jest ona wykonana z drewna, cegły, betonu, ...
- ☑ Elementy przystosowane do zamocowania szklarni do podłoża znajdują się w obrębie aluminiowej podstawy na około 55 mm do 43 mm.

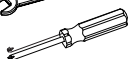
### Szyby

- ☑ Po zamontowaniu ramy aluminiowej można przystąpić do montażu szyb.
- ☑ Pomimo, że zastosowane szkło jest szkłem bezpiecznym hartowanym, należy je zawsze traktować jako potencjalnie niebezpieczne i obchodzić się z nim ostrożnie.
- ☑ Przed przystąpieniem do pracy należy upewnić się, że rama jest pozbawiona zanieczyszczeń. Należy uważać na wiatr.
- ☑ W przypadku umieszczania paneli obok szklarni w trakcie montażu, zaleca się położenie ich pochyło.
- ☑ Należy zacząć od paneli dachowych, przesuwać się od jednego końca do drugiego.
- ☑ W celu zprzymocowania płyt dachowych należy oprzeć się o rynny i wsunąć je pomiędzy pręty zbrojeniowe, aż dotrą do kalenicy i wpasują się w konstrukcję.
- ☑ Panele ścienne należy wsunąć pod kątem między pionowe pręty aluminiowe, wsunąć do góry i włożyć we wgłębienie pod rynną.
- ☑ Należy upewnić się, że dolna część panelu szklanego spoczywa prawidłowo na podstawie.
- ☑ Płyta finalnie powinna być w pozycji pionowej i prostopadłej, zabezpieczona przez zagłębienia na dole i na górze.
- ☑ Należy wsunąć kauczukowe uszczelki, używając kciuka i palca wskazującego jako wytycznej. Wszystkie uszczelki są fabrycznie dłuższe niż jest to wymagane, dlatego powinny być dostosowane wielkościowo podczas regulacji.
- ☑ Jeżeli uszczelka gumowa wydaje się sucha, należy użyć wody z mydłem, aby ułatwić montaż w listwie przyszybowej.
- ☑ Po zakończeniu montażu, uszczelki powinny być zamontowane płasko i równo.
- ☑ Zalecamy pozostawienie uszczelki na godzinę lub dwie przed przycięciem do odpowiedniej długości, ponieważ mogą się rozciągnąć, a następnie skurczyć podczas wkładania.
- ☑ Prosimy o nie przecinanie uszczelki, dopóki wszystkie nie zostaną włożone.

Część	#	mm	Ilość	Część	#	mm	Ilość
	L12	640	1		L01A L01B	2073 2073	1 1
	L13A	640	1		L01C L01D	1474 1474	1 1
	L13B	640	2		L04	592	1
	L38	640	1		L05	1300	1
	L15	602	2		L06A L06B L06C L06D	1547 620 640 1558	4 1 1 2
	L16	602	2		L07A L07B L07C L07D	1869 3706 626 646	1 1 1 1
	L17	700	4		L08A L08B L08C L08D	2358 2358 1780 1780	1 1 1 1
	L18	638	2		L08E L08F L08G L08H	1474 2046 2069 2069	5 5 1 1
	L21	259	1		L09	3708	1
	L22	1865	1		L10	3708	1
	L23	2042	5		L11A L11B	1816 1816	1 1
	L37	1842	1				

Część	#	mm	Ilość	Część	#	mm	Ilość
	M01	M6	113		W2		2
	M02	M5	2				
	Z01	Ø4*16	24		W5		2
	Z02	Ø4*6	4				
	H3		2		W07A	655	1
					W07B	645	1
					W07C	3758	1
					W07D	1900	1
	J04		1		W08	350	6
					W09		13
	J04L		1		W11		20
	J04R		1		W13	Ø12*28	3
	J11		2		W14		210
	J13		4		W15		6
	J15	Ø6.5*20	4		W21	Ø12*Ø6*1.5	2
					W16		1
					W17		1
	J18	1.82M	2		W46		2
	J19	78M	1		S01	M6*10	90
					S02	M6*16	24
					S03	M6*40	3
	T01		1		S04	M6*14	5
	T02		1		S05	M5*25	2
	S04				S07	M6*60	12
							
							

**Ważna wskazówka:**

Nie trzeba wszystkiego demontować, jeśli jeśli zapomni się o wkręceniu śrub S01, można je zastąpić śrubami S04!

## Montaż podstawy

Ważne jest, aby podstawa szklarni była idealnie prostopadła, tak aby wymiary przekątnych były identyczne. Szklarnia musi być również równomiernie wypoziomowana z przodu i z tyłu oraz idealnie pionowa.

Zakotwiczenie szklarni w gruncie jest niezbędne. Zalecamy użycie kotew mocujących, jeśli mamy do czynienia z płytą fundamentową, w tym przypadku należy przyciąć wsporniki kotew.

Alternatywnie, kotwy mogą być zabetonowane w podłożu (podstawa fundamentowa o średnicy min 300 mm i głębokości min 400 mm). Najlepiej jest zrobić to na końcu, jeśli czas na to pozwala. Na czas budowy należy zawsze tymczasowo przymocować i zabezpieczyć konstrukcję.

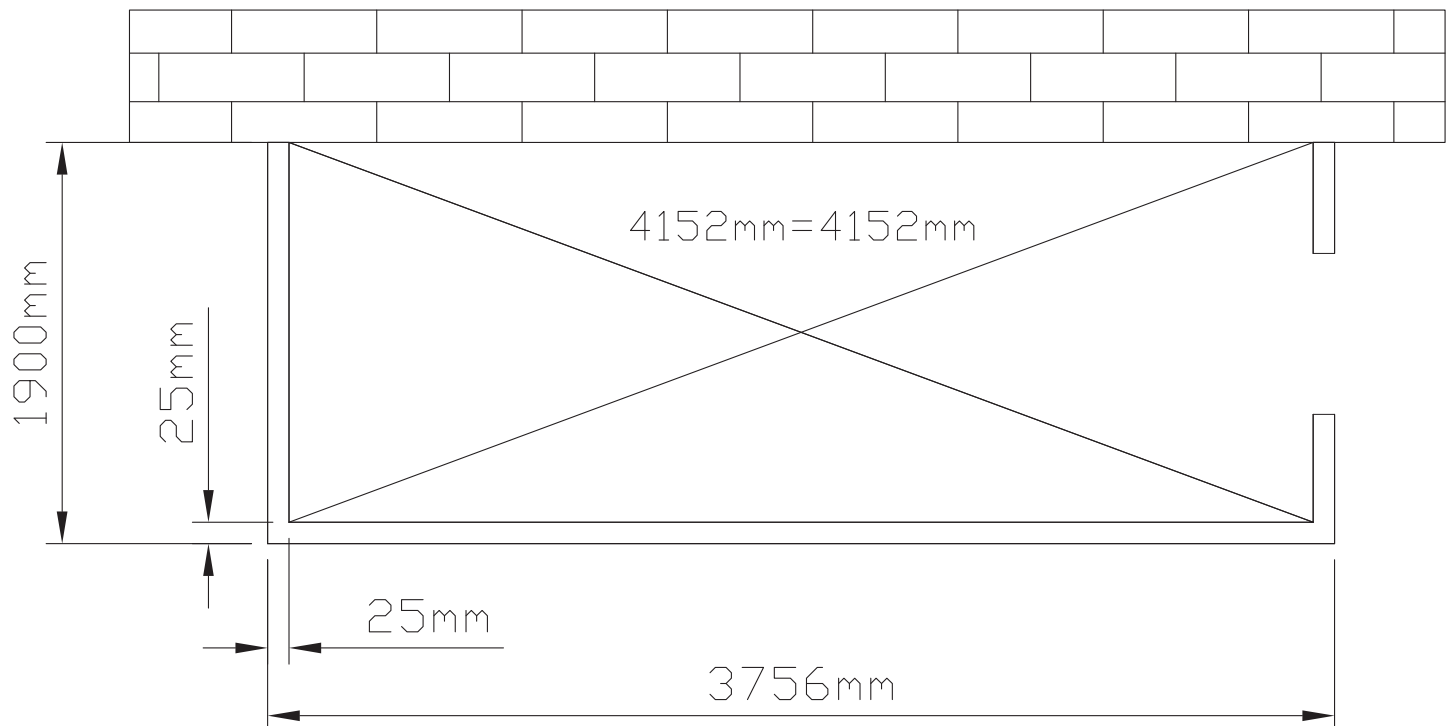
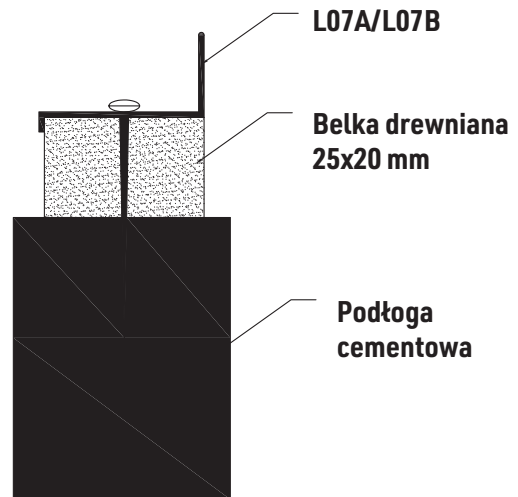

# Montaż podstawy

**Uwaga:** Proszę usunąć folię ochronną z powierzchni części W08 i W07 A (B/C/D) przed montażem podstawy

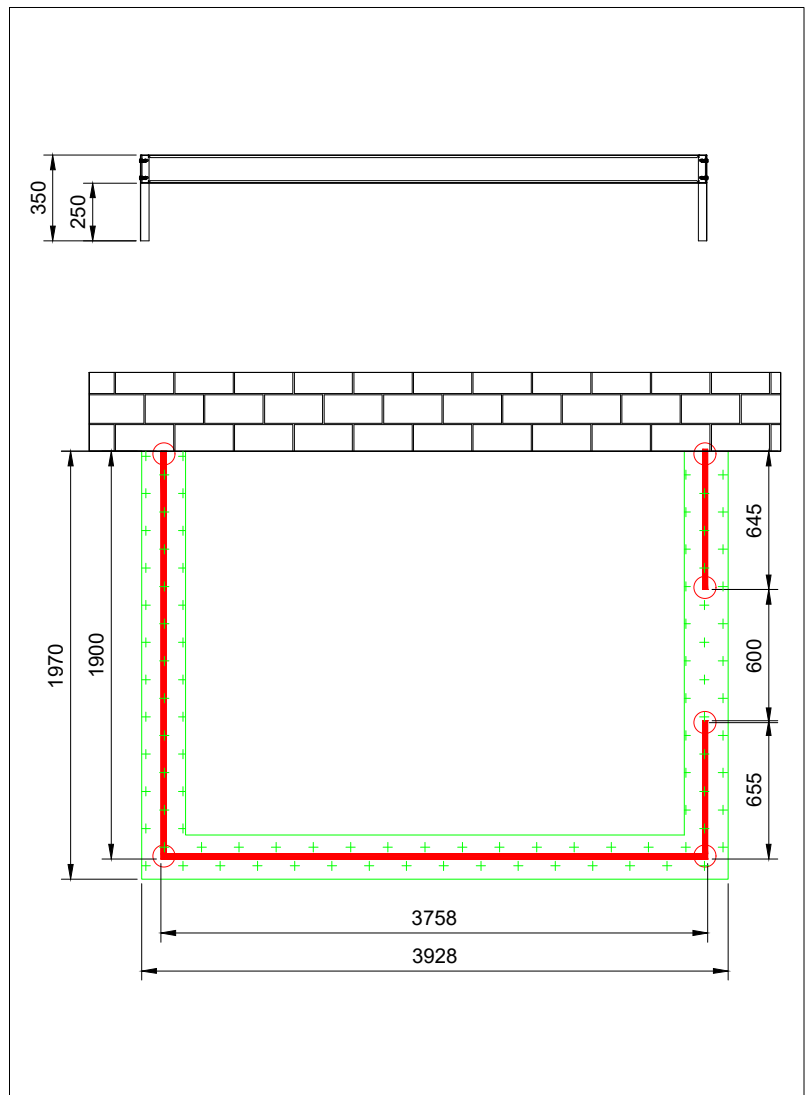
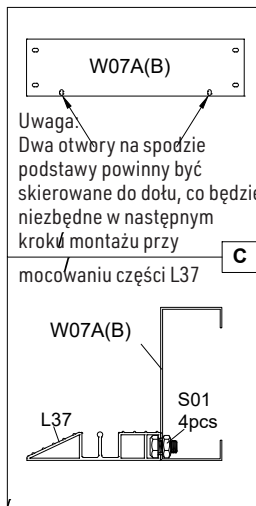
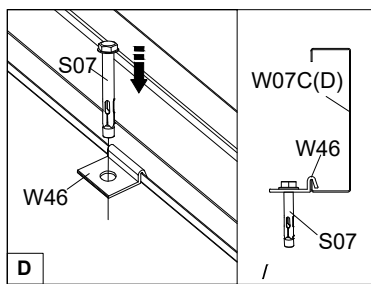
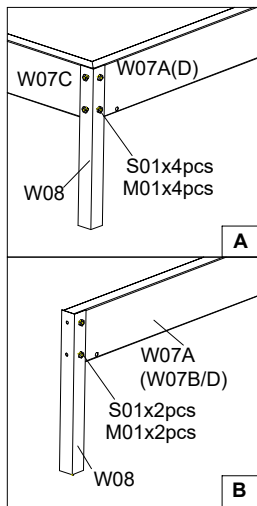
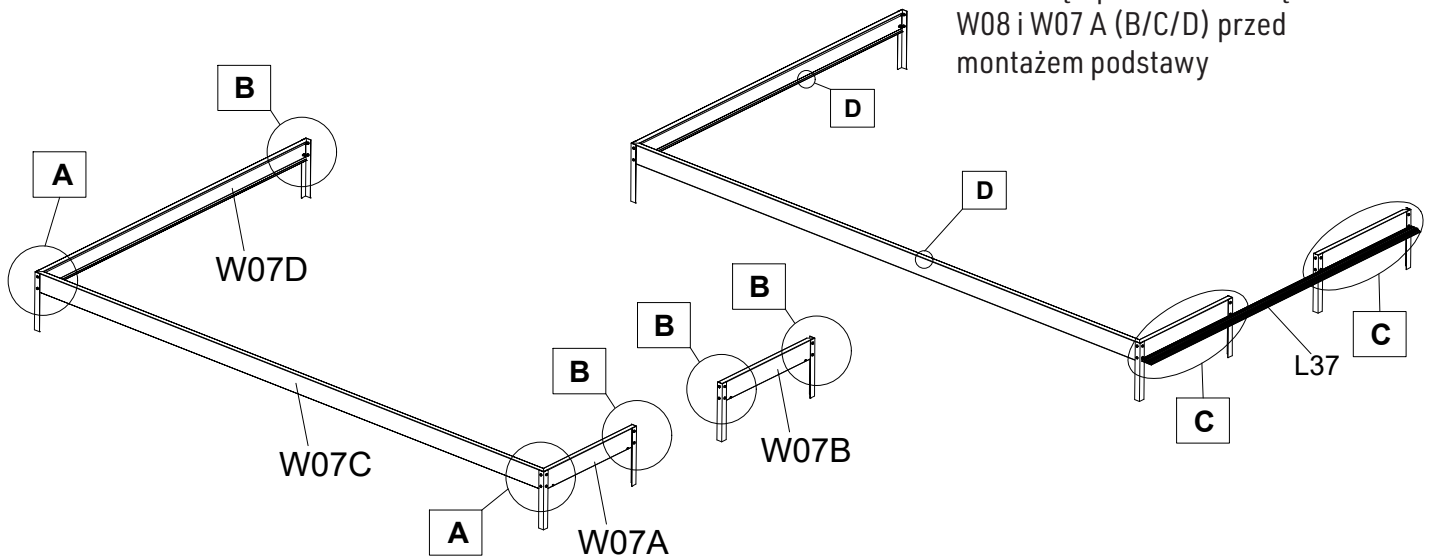

# Montaż drzwi

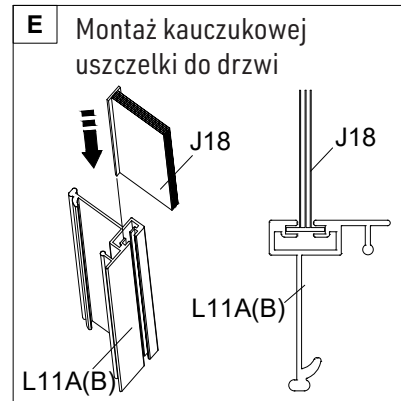
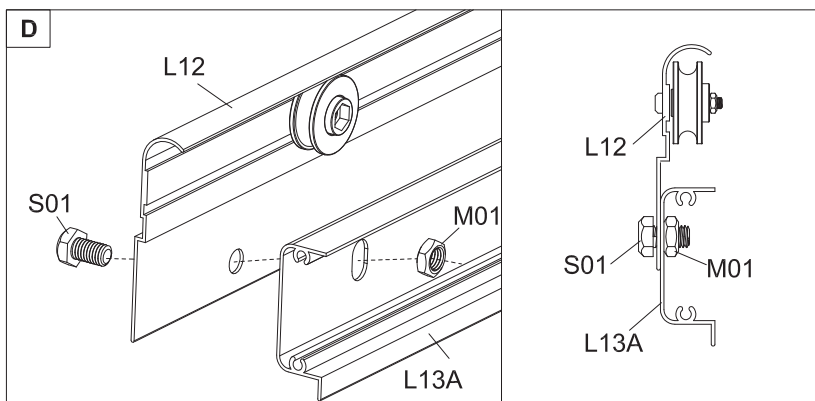
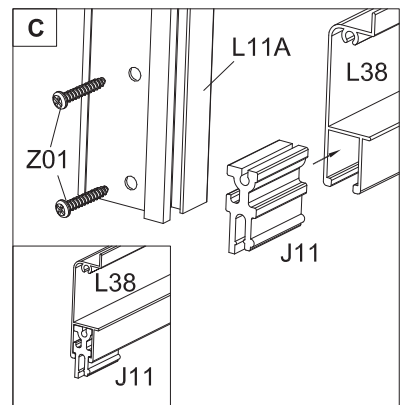
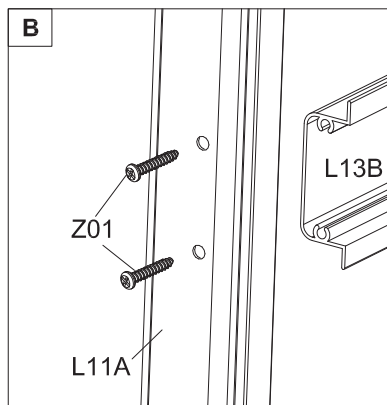
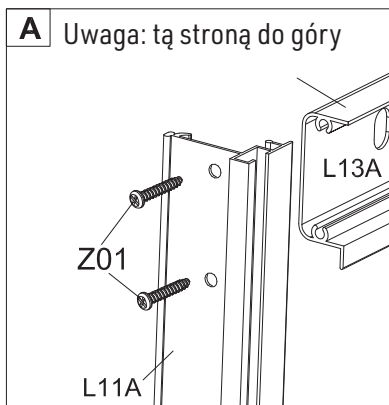
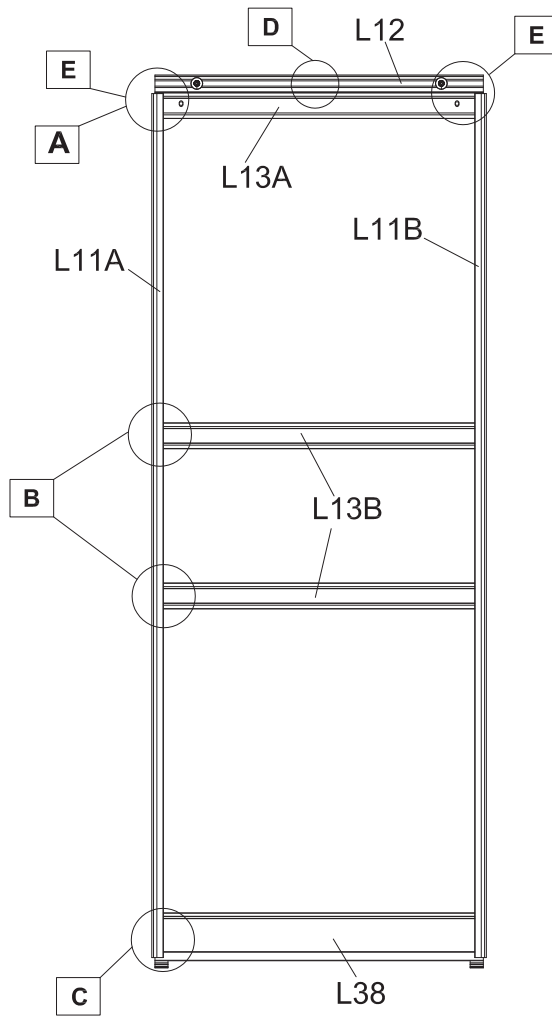

# Montaż okna

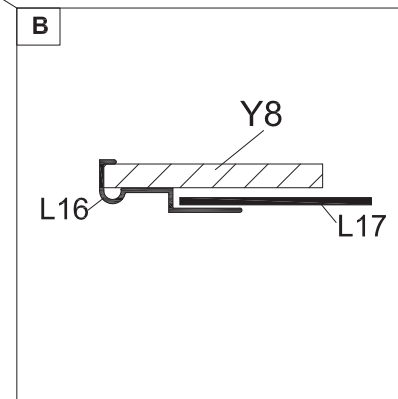
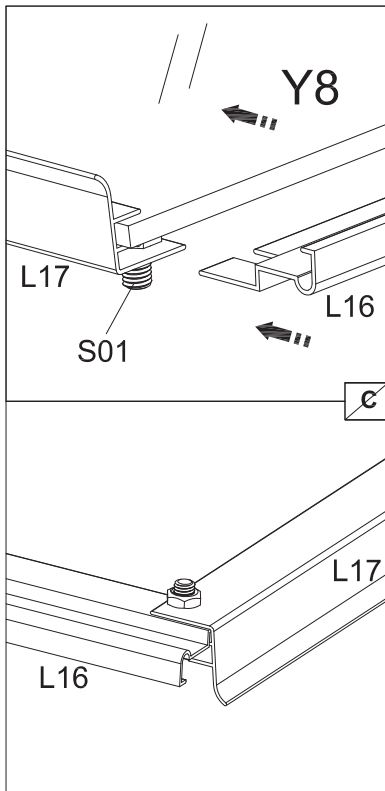
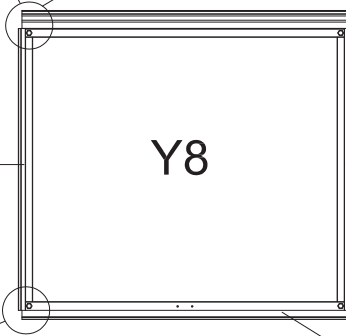
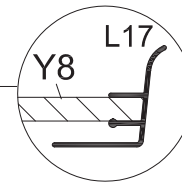
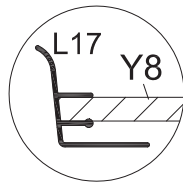
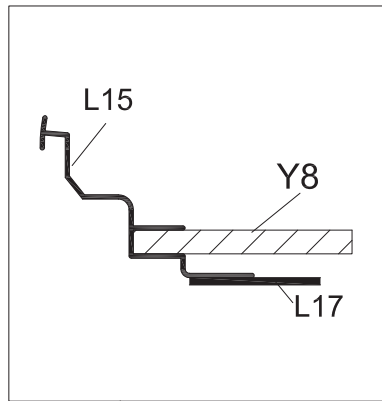
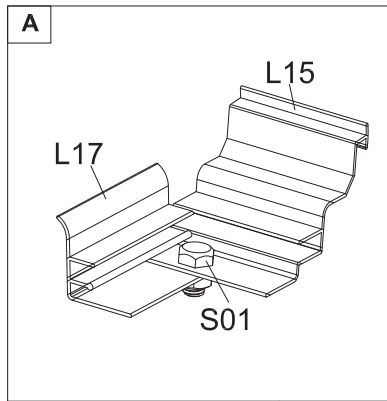

# Montaż przedniej ramy ściennej

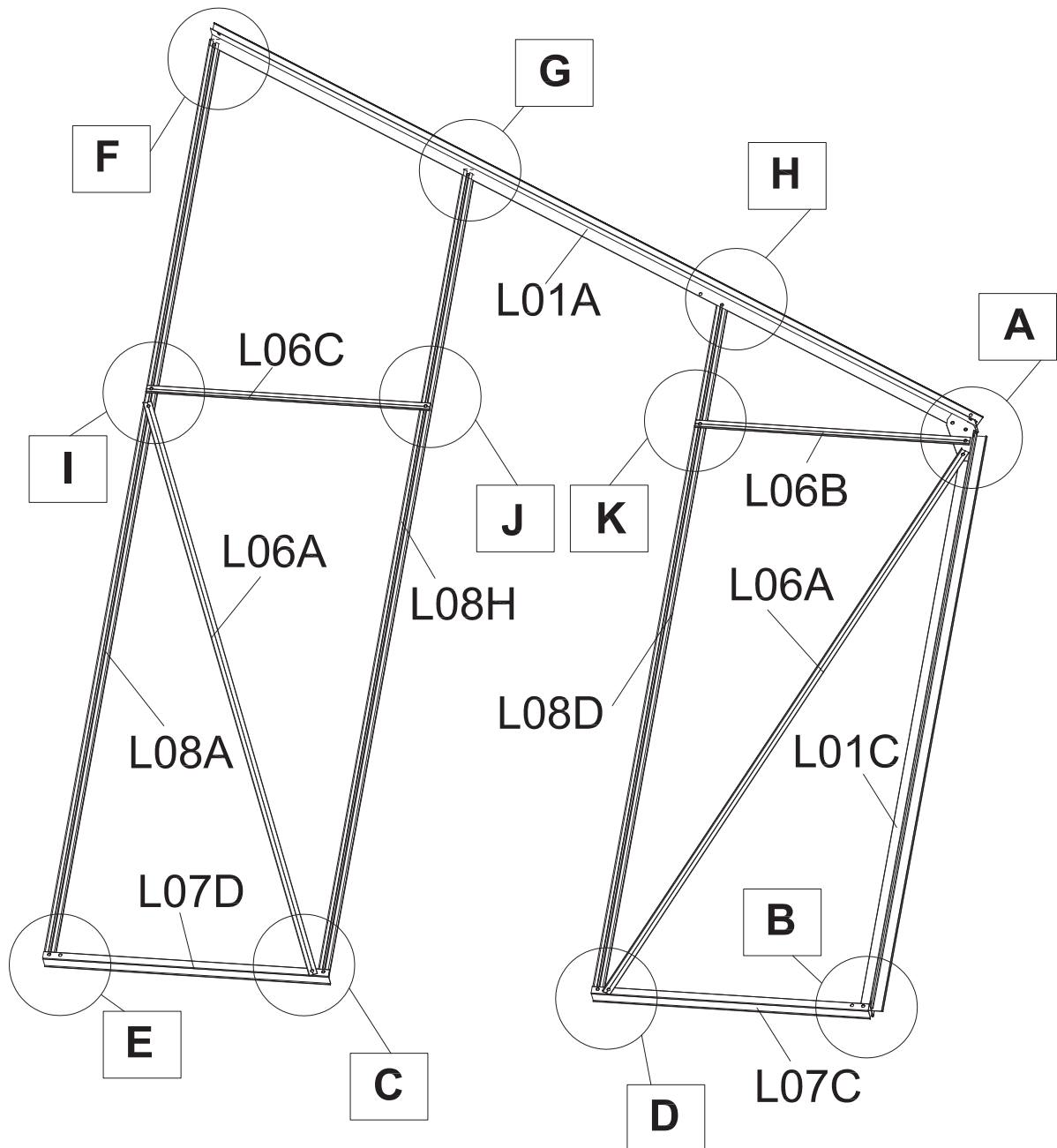

# Montaż przedniej ramy ściennej

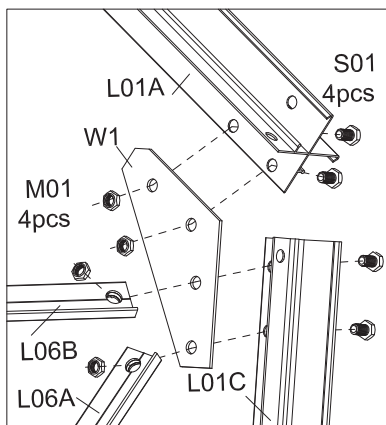

Prosimy o nie dokręcanie nakrętek przed zamontowaniem części L09

**A**

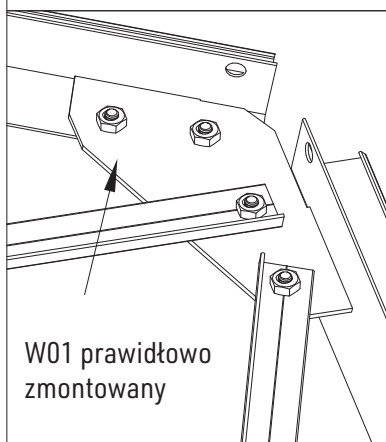

W01 prawidłowo zmontowany

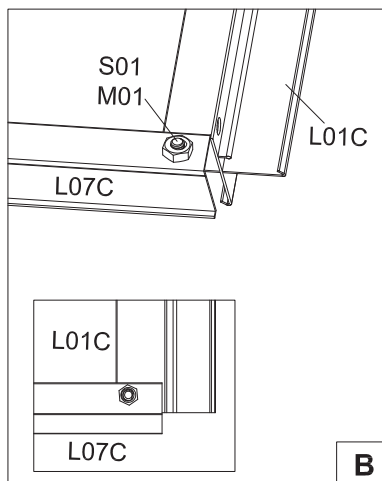

**B**

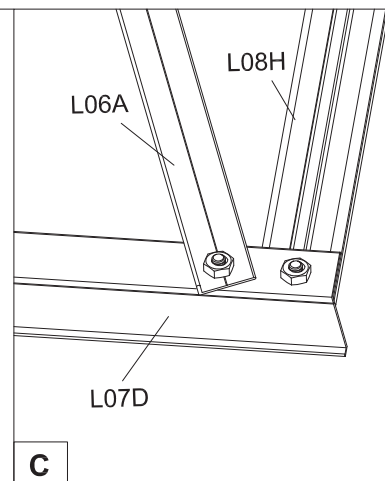

**C**

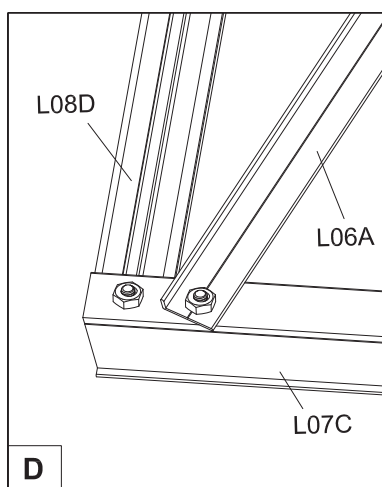

**D**

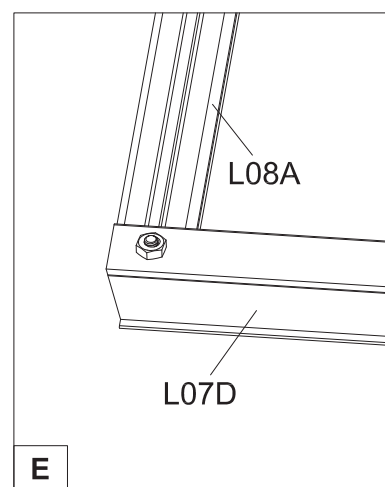

**E**

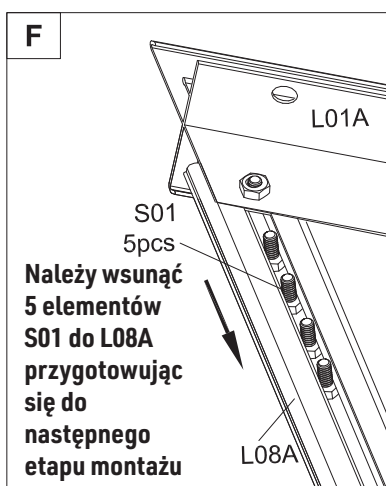

Należy wsunąć 5 elementów S01 do L08A przygotowując się do następnego etapu montażu

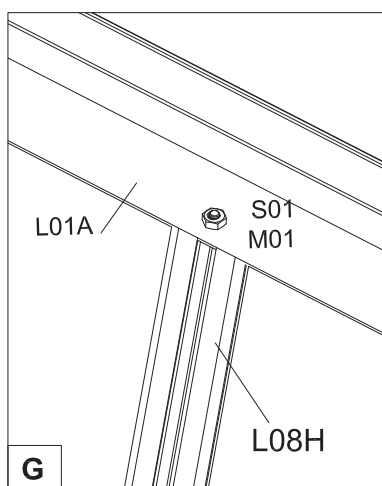

**G**

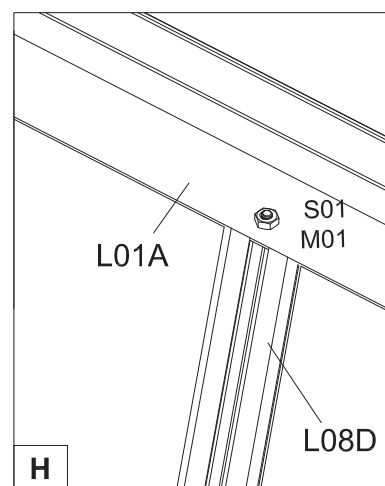

**H**

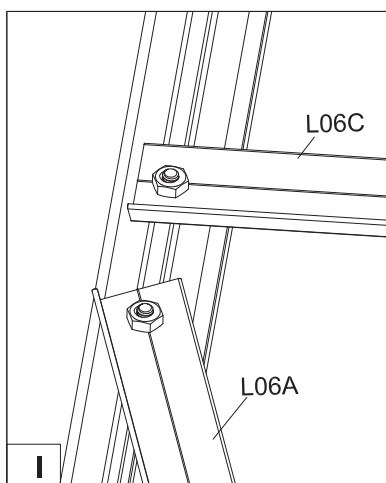

**I**

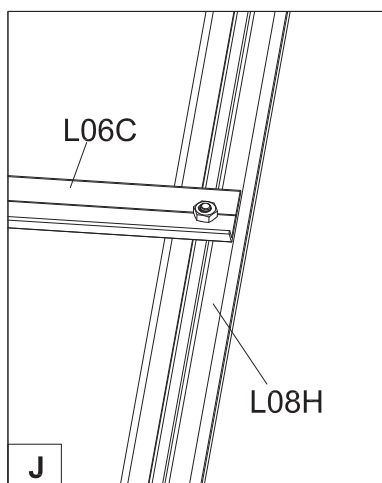

**J**

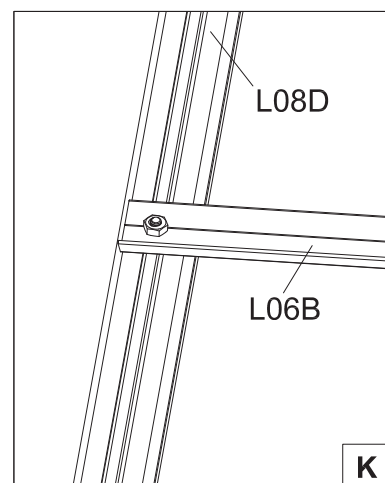

**K**

# Montaż przedniej ramy ściennej

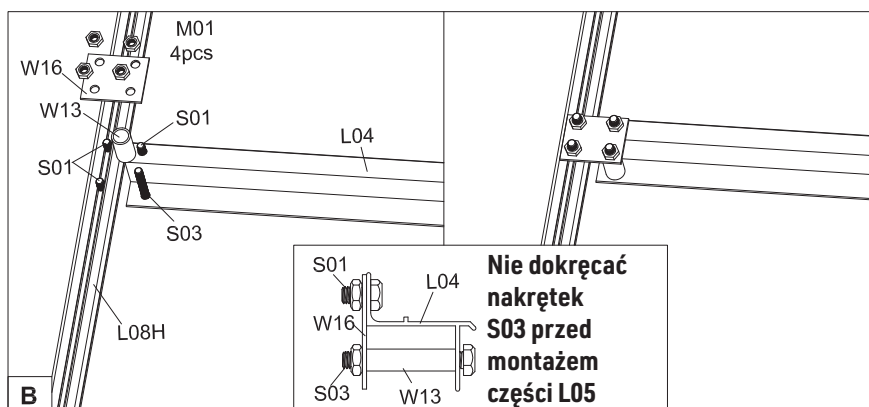
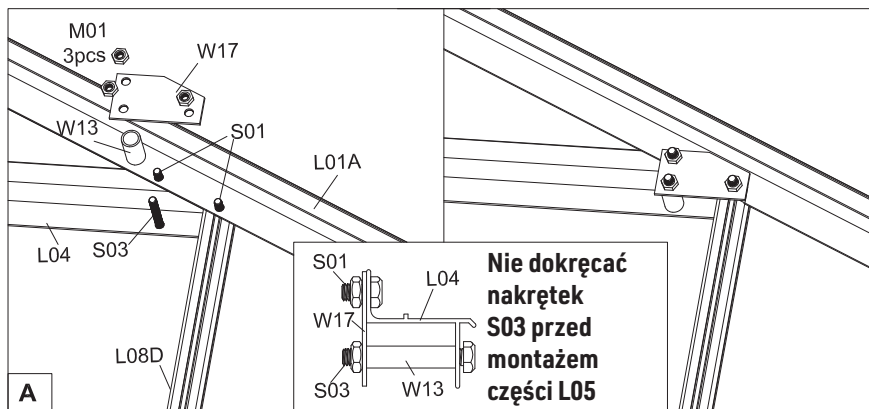
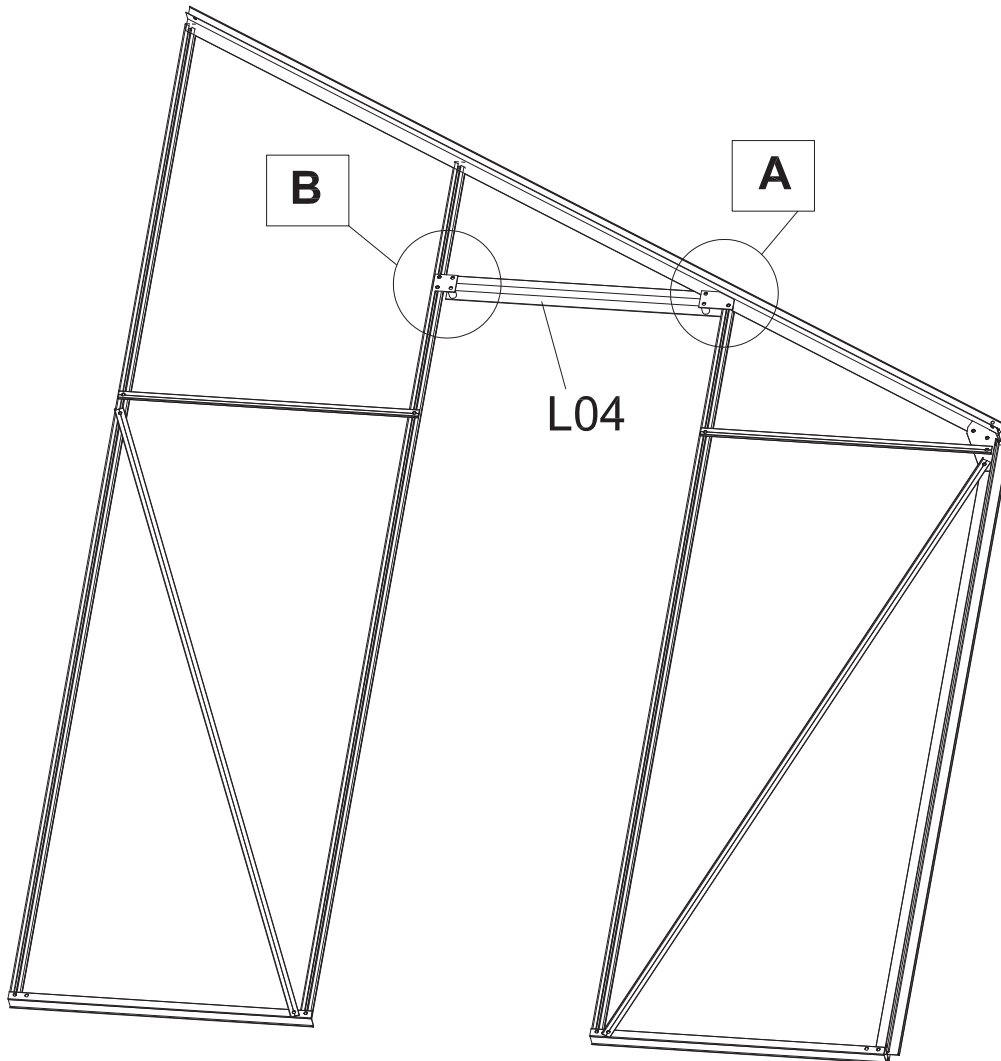

# Montaż ściany tylnej

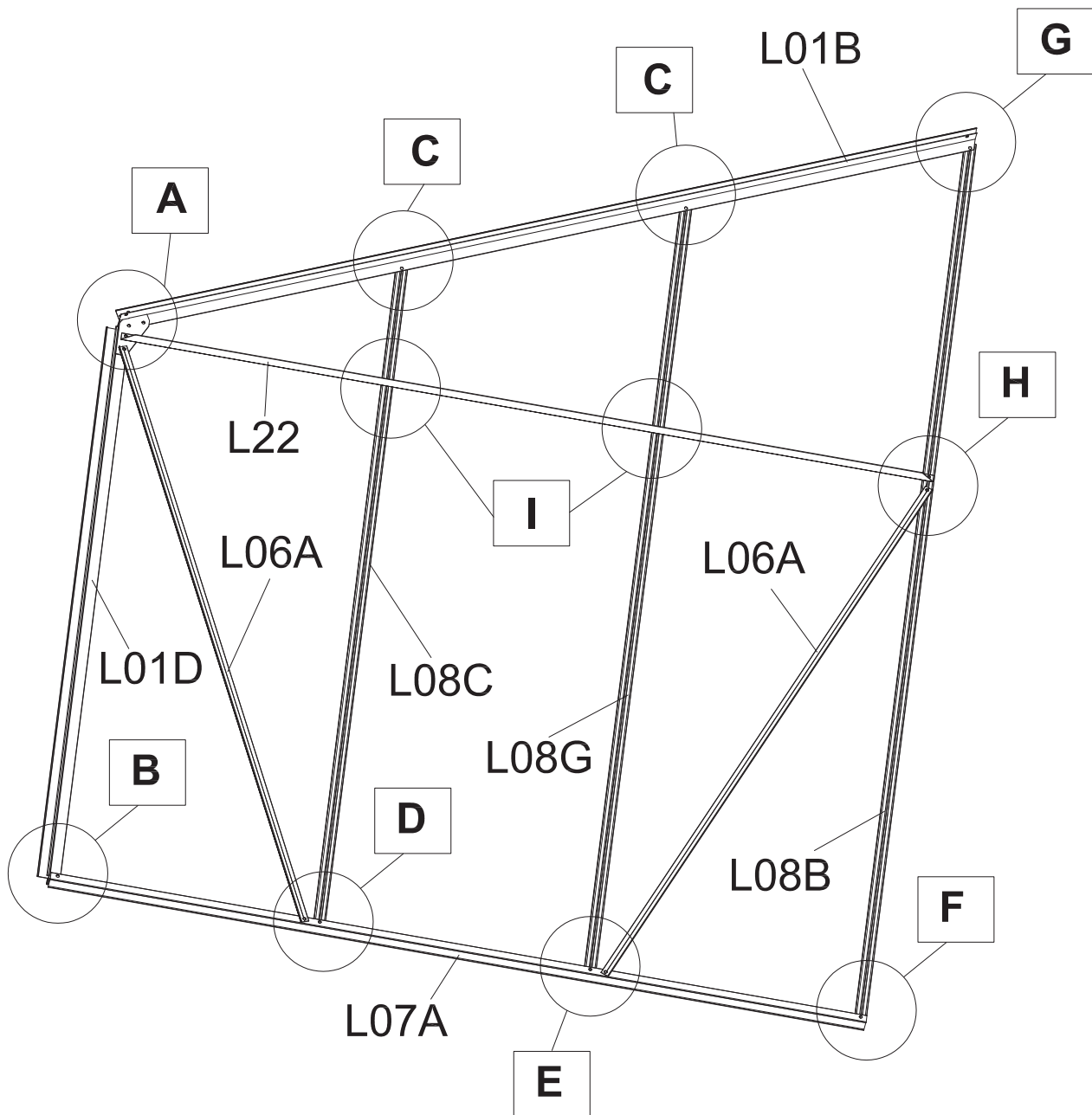

# Montaż ściany tylnej

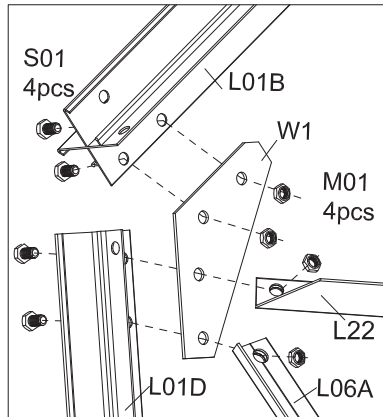

Nie dokręcaj nakrętek przed zamontowaniem części L09

**A**

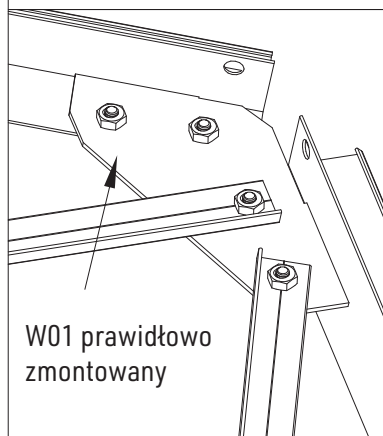

W01 prawidłowo zmontowany

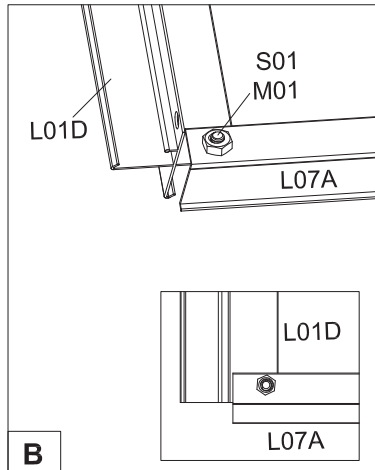

**B**

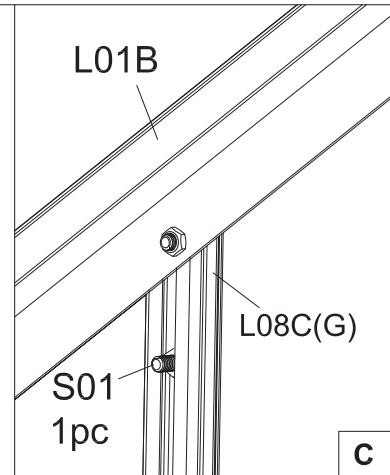

**C**

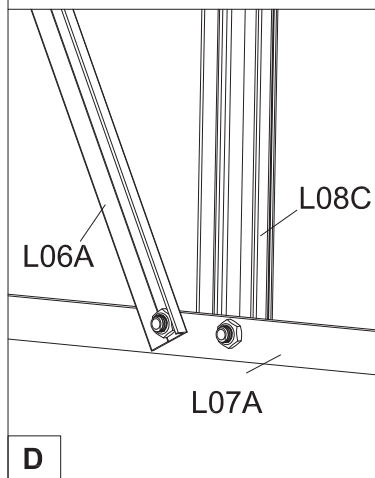

**D**

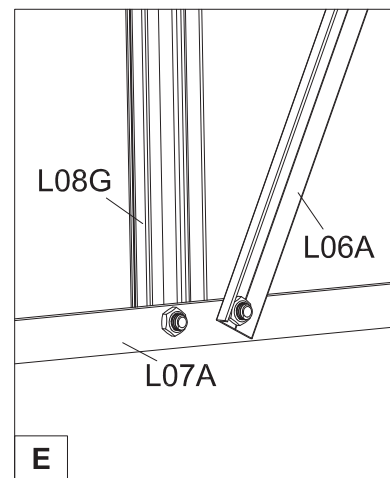

**E**

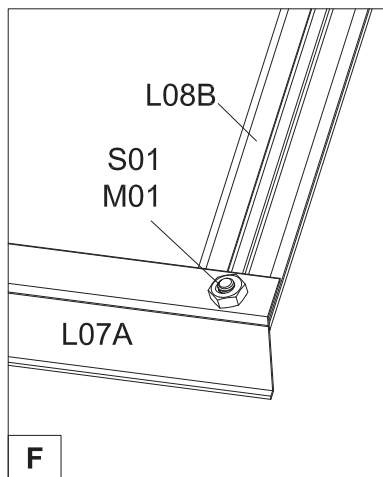

**F**

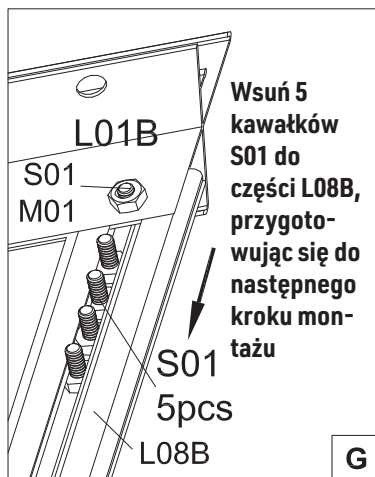

**G**

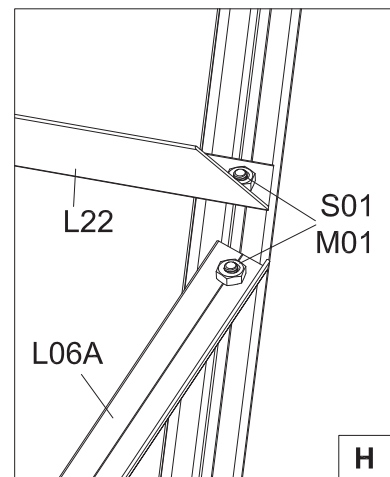

**H**

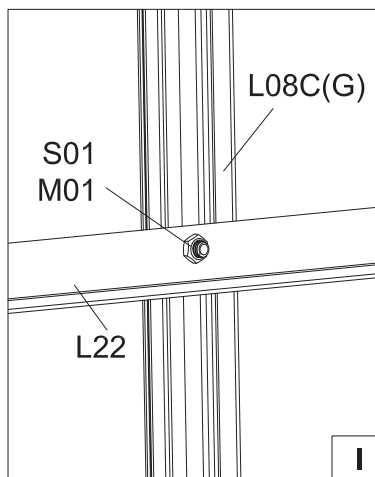

**I**



# Montaż ścian bocznych

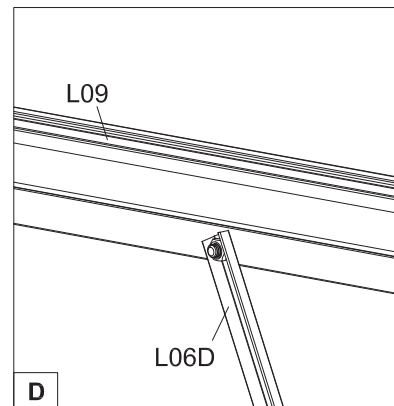
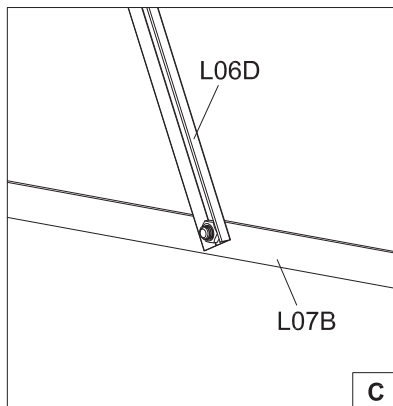
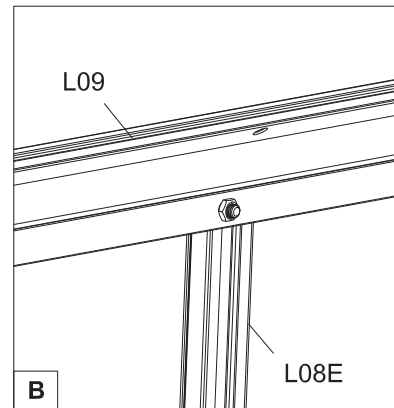
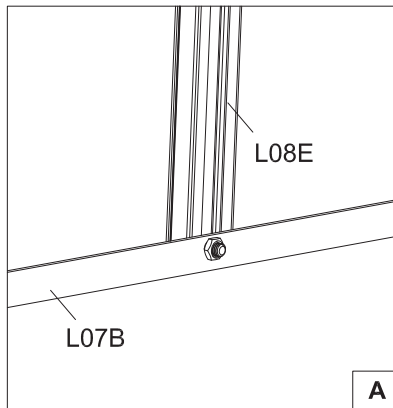
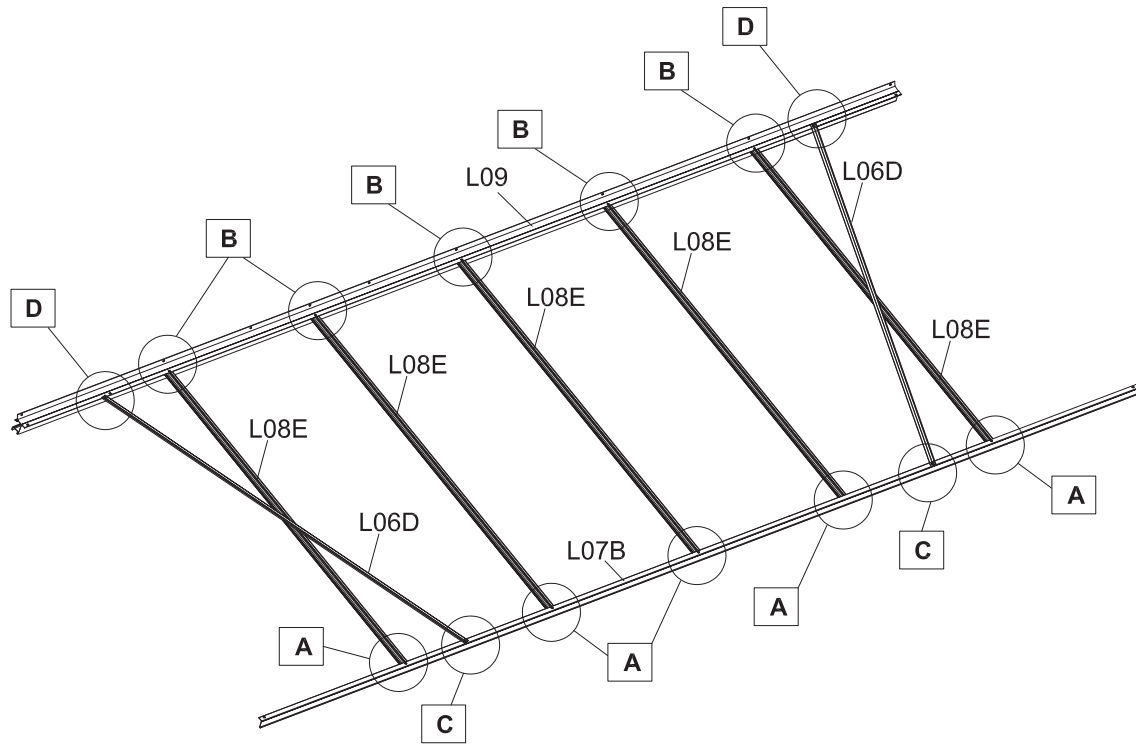

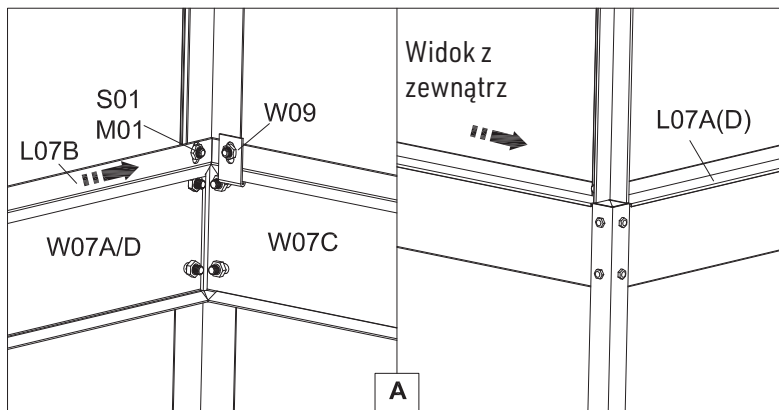
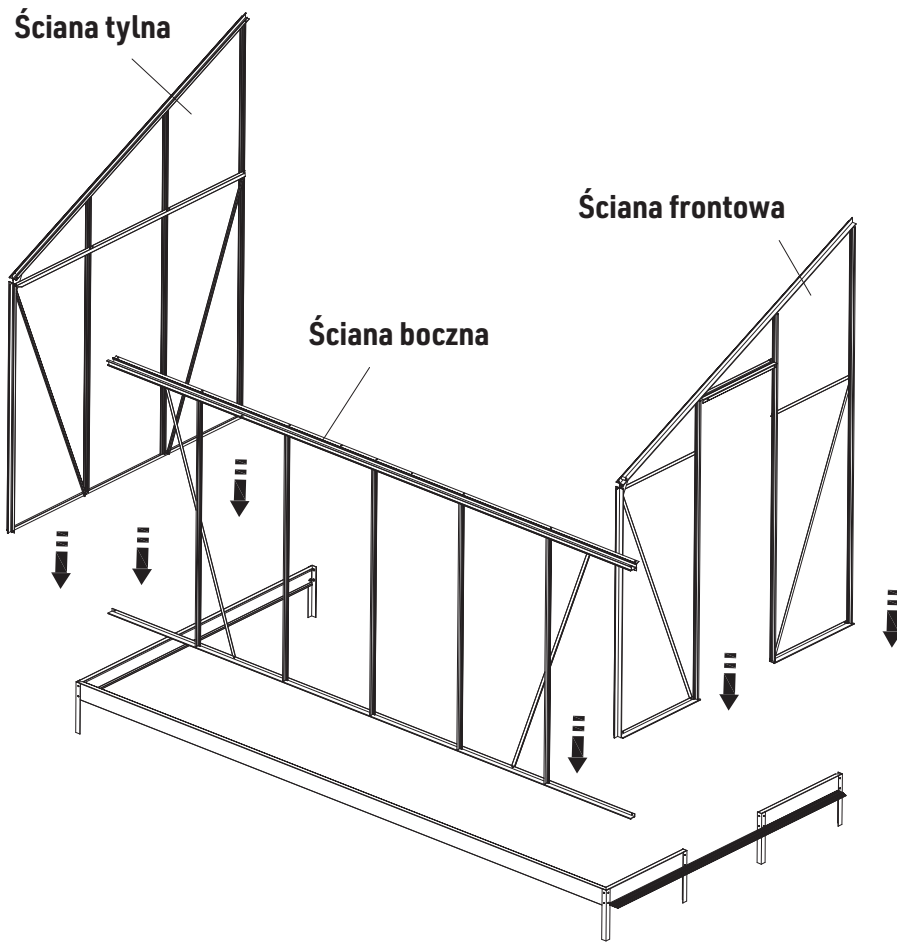

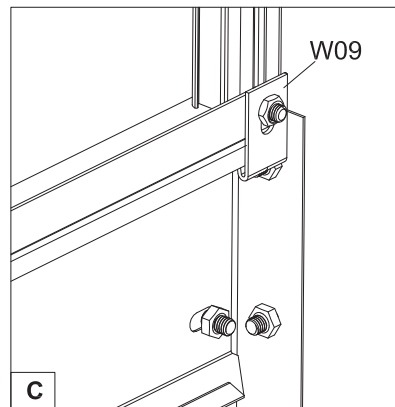
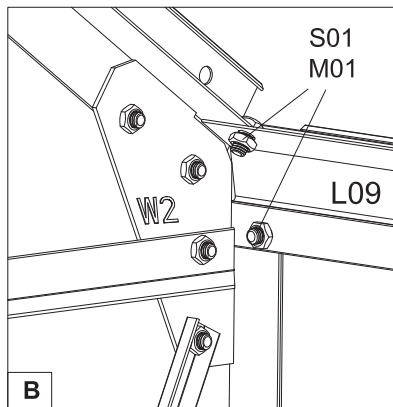
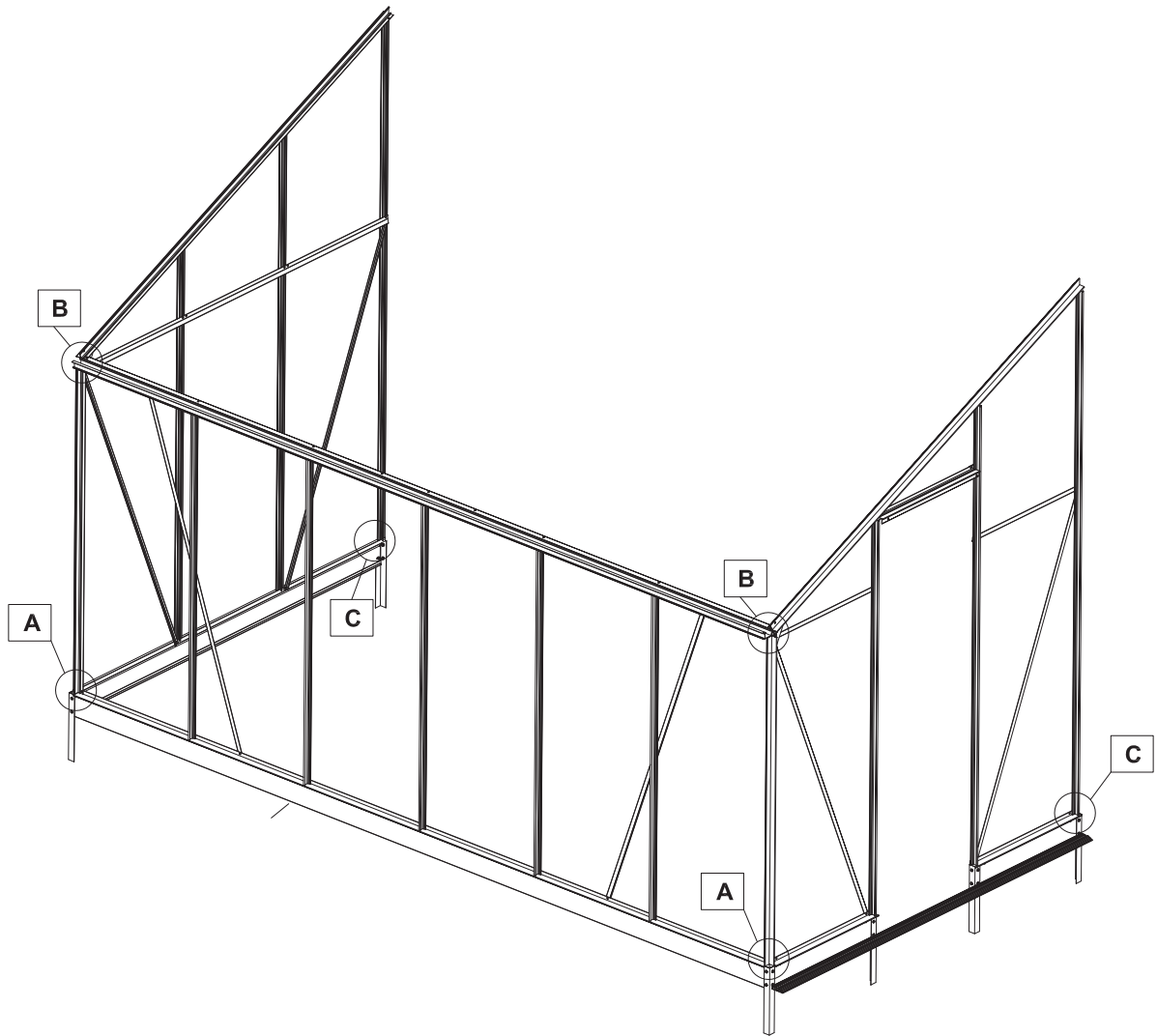

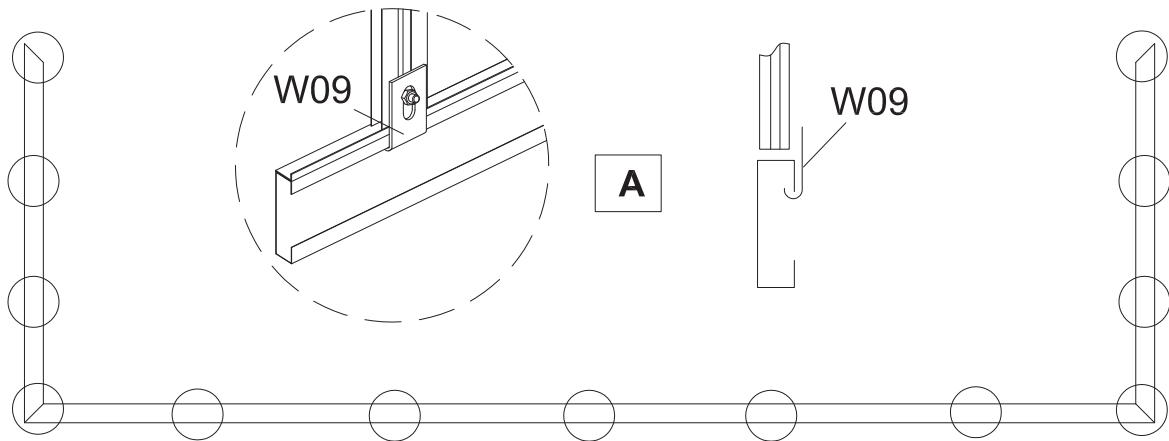
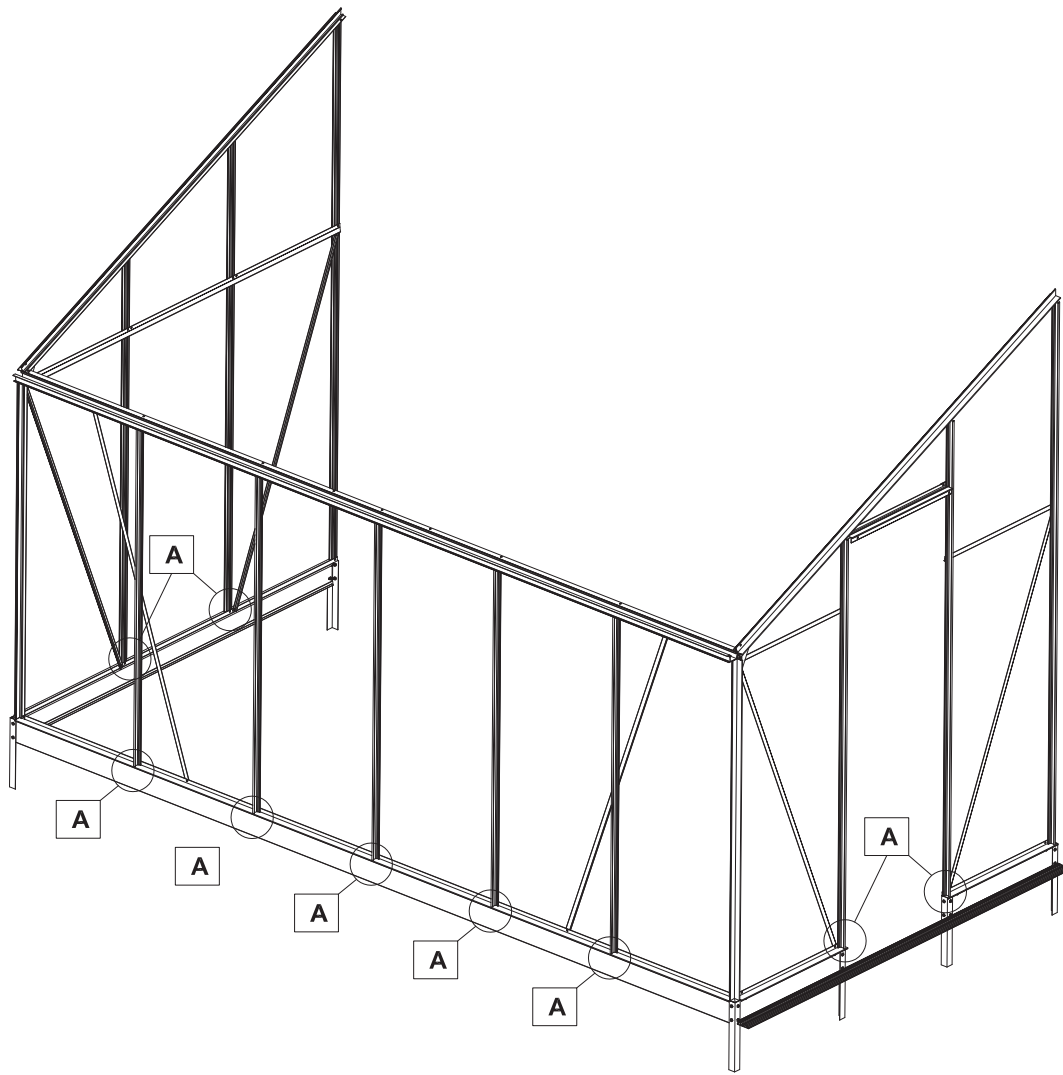

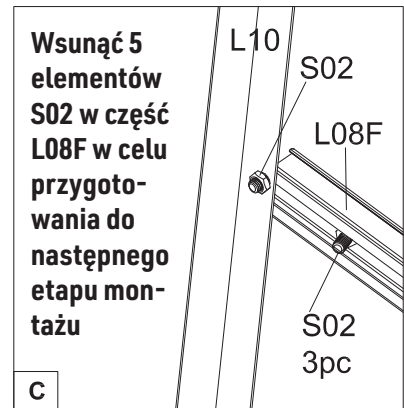
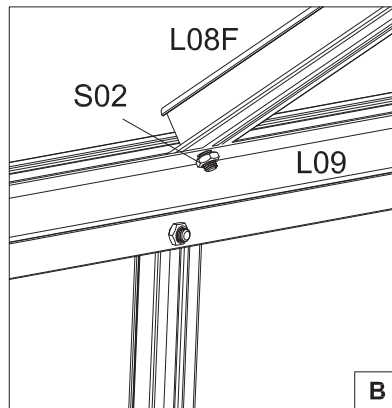
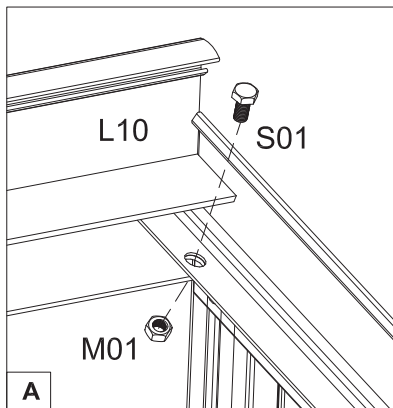
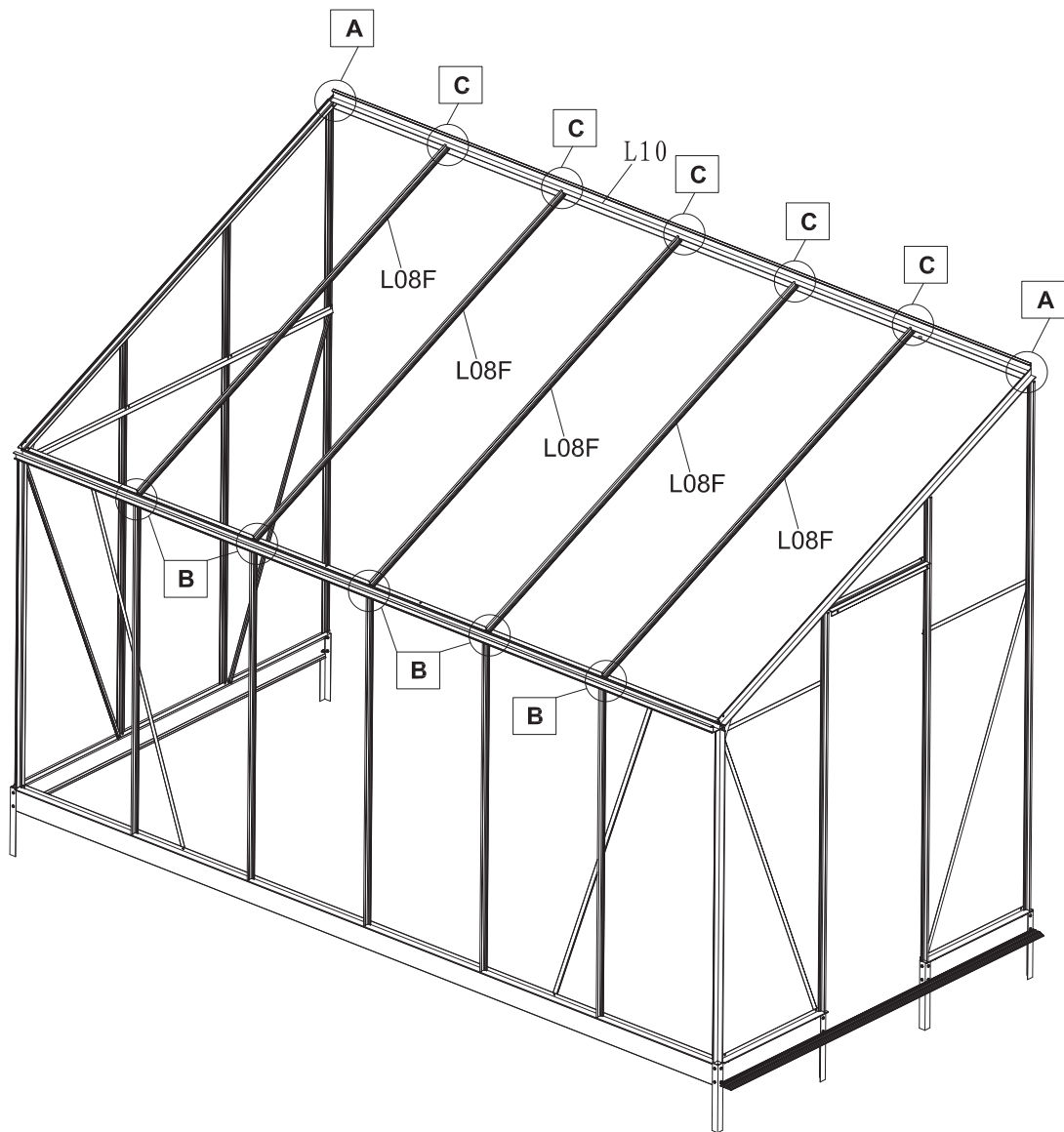

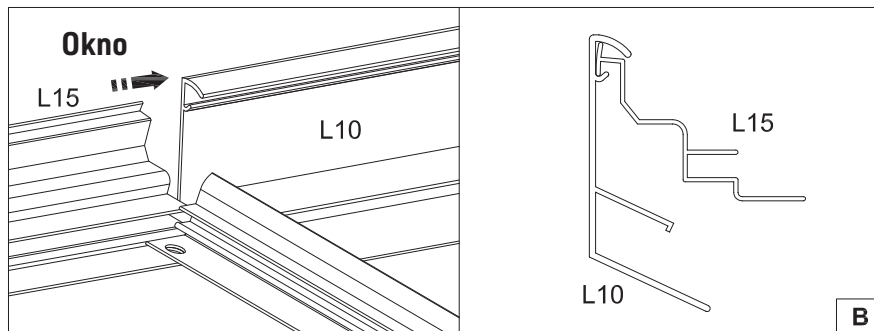
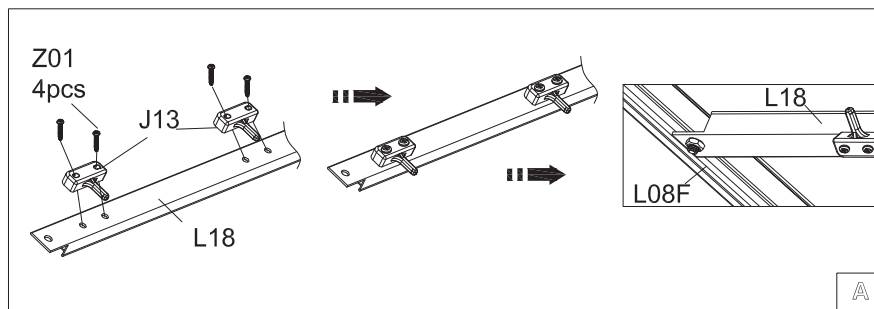
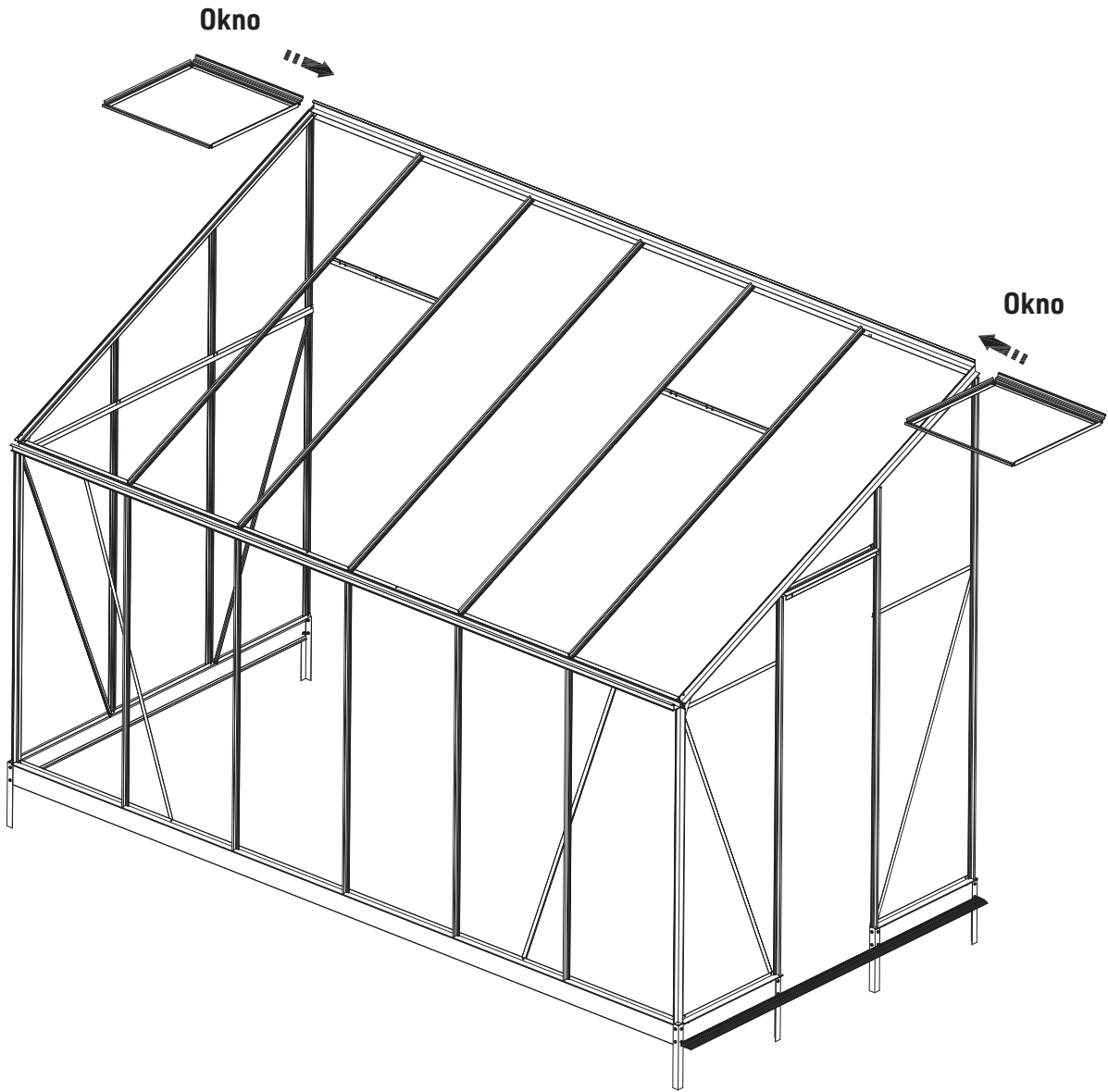

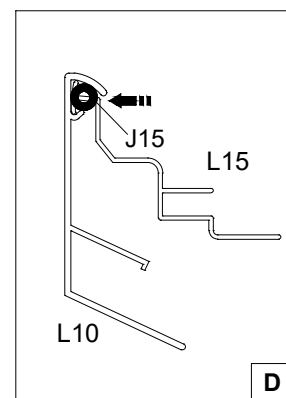
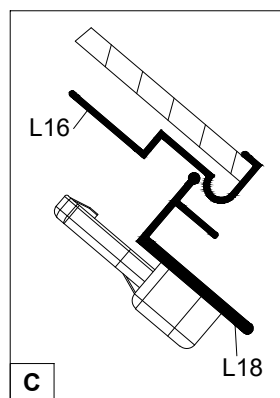
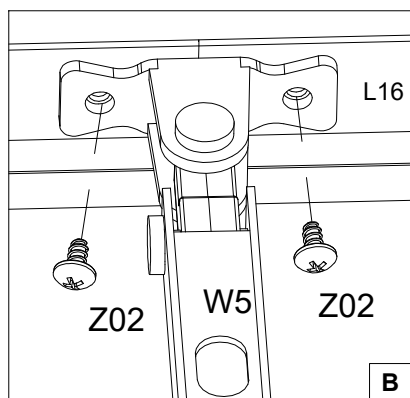
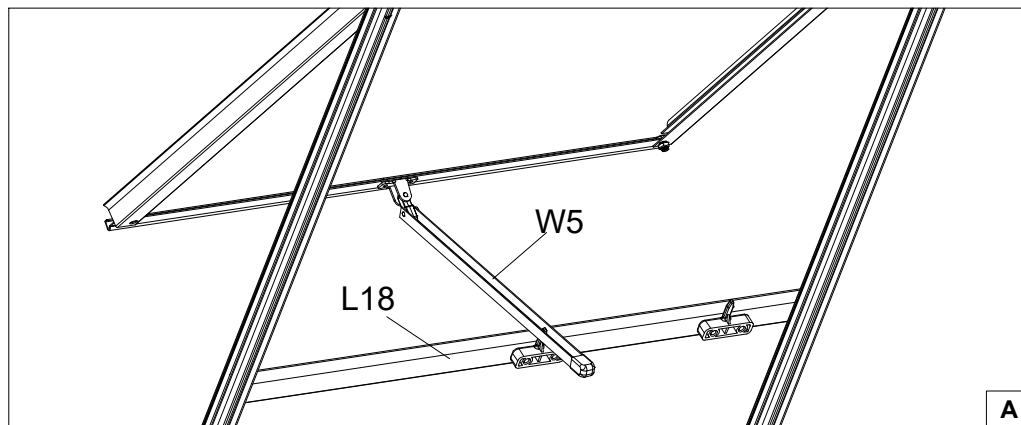
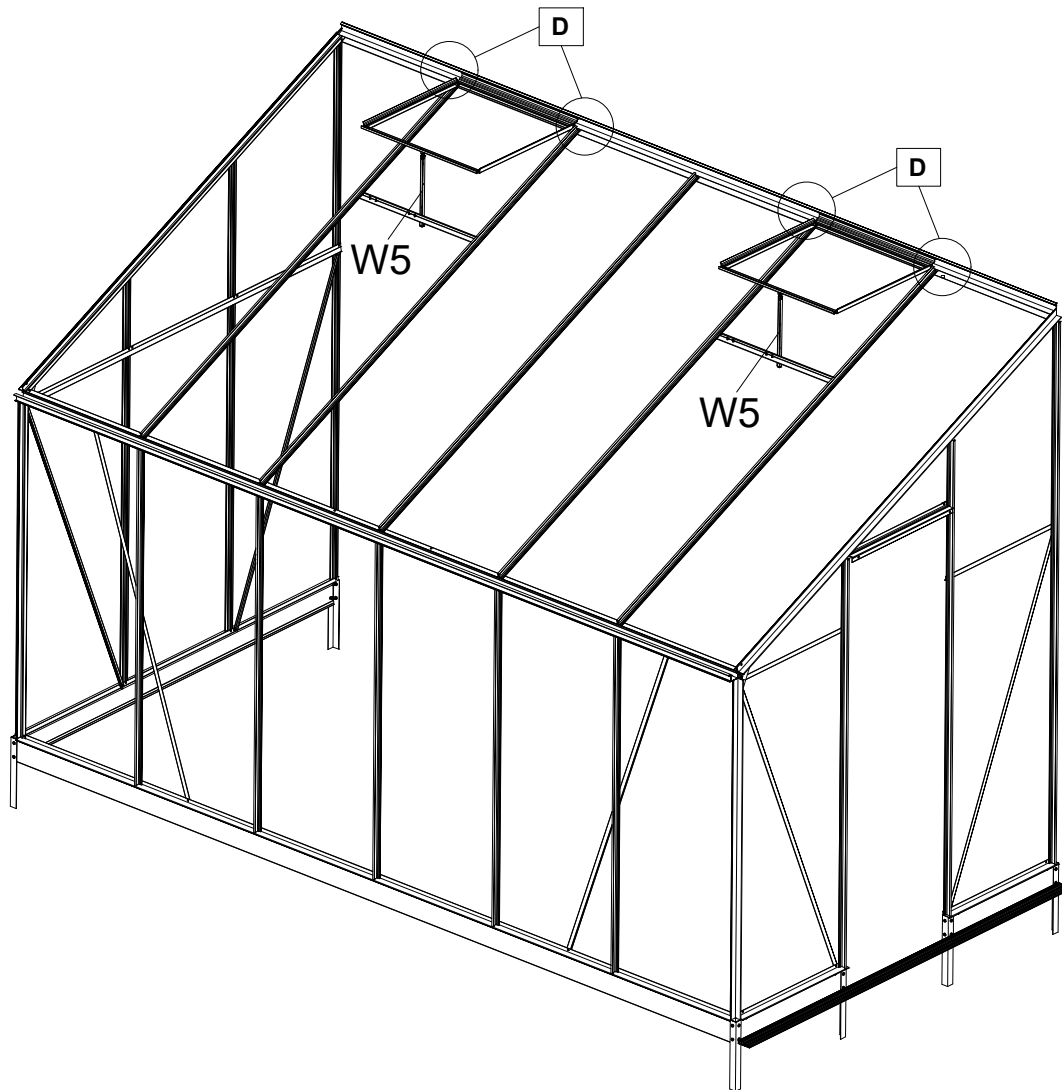

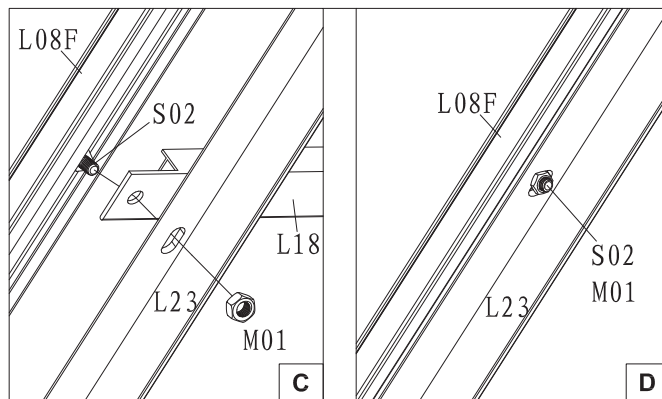
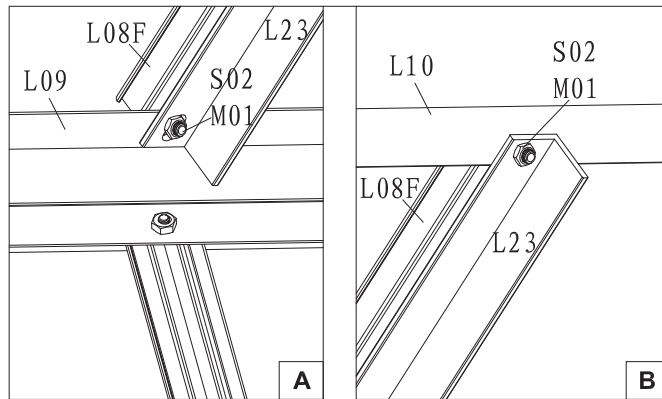
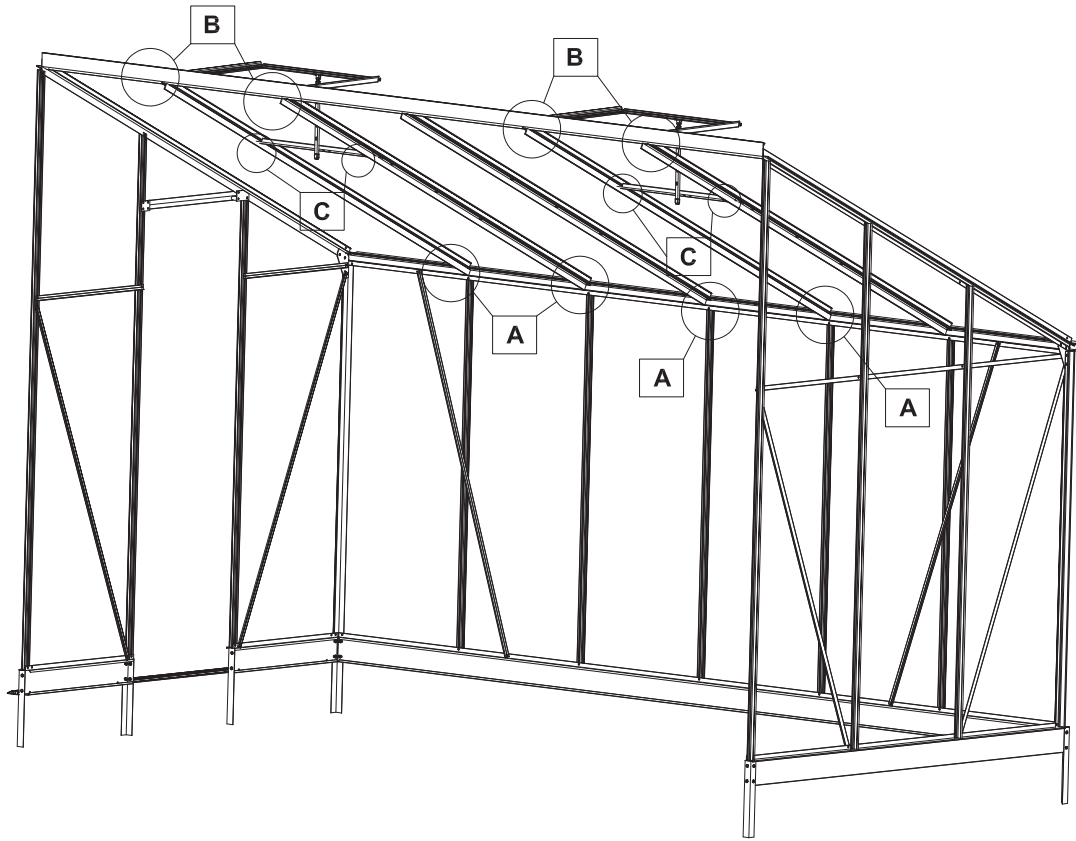

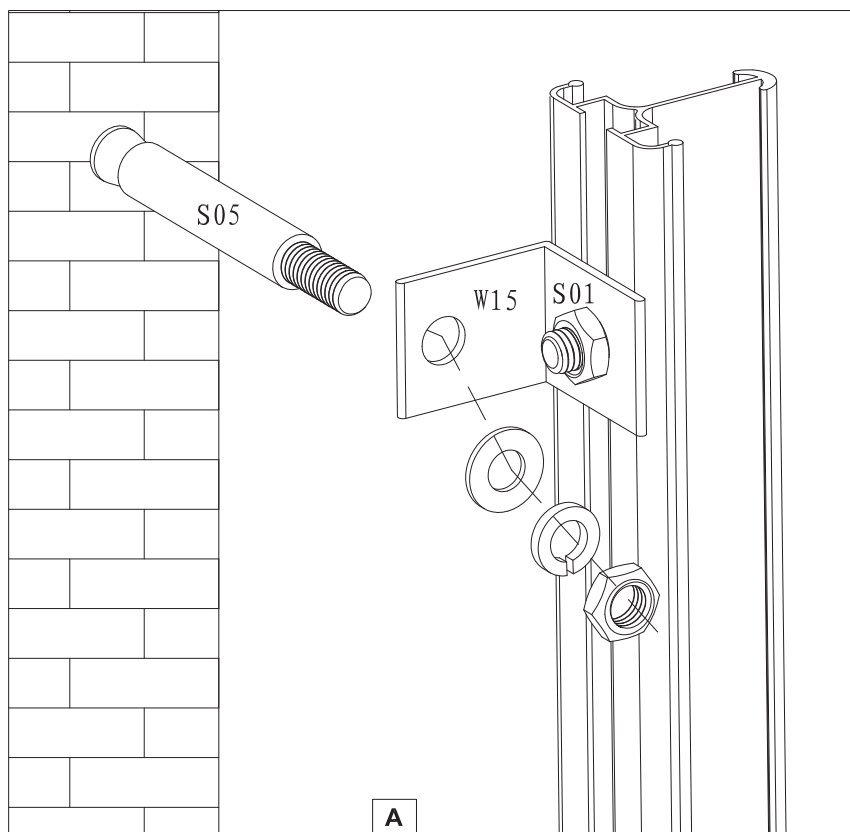
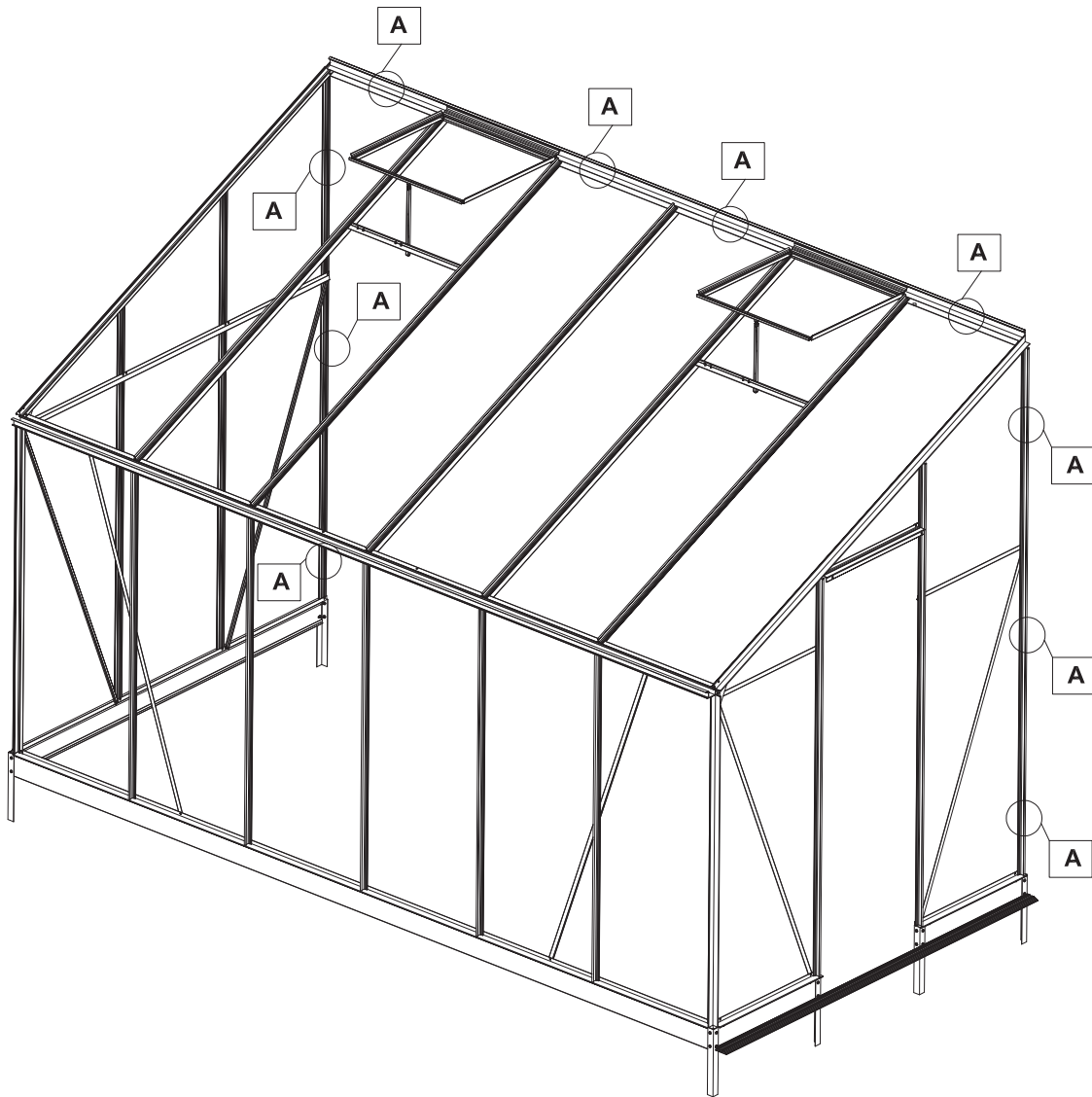

Montaż uszczelki kauczukowej J19

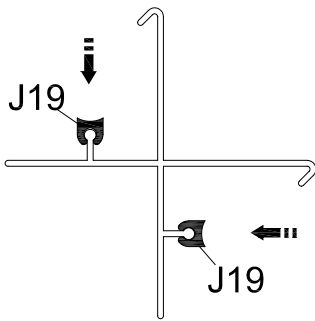

L01

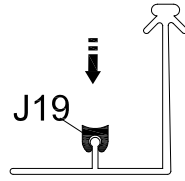

L03

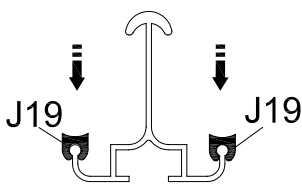

L08

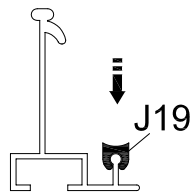

L11

Montaż szklanych płyt

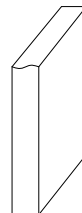
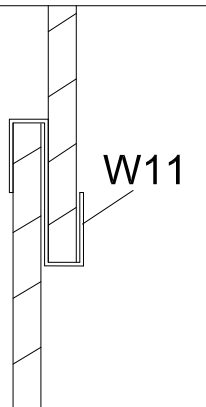
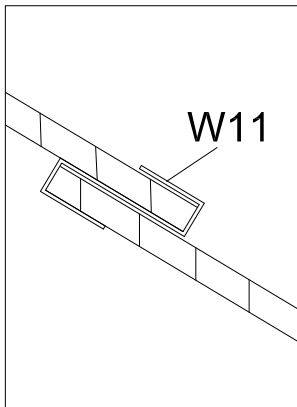
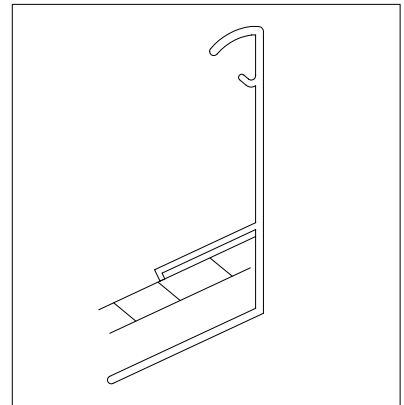
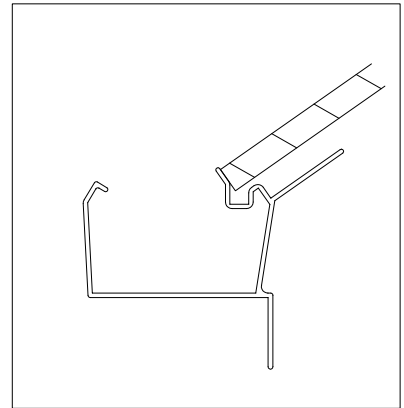

Należy uważać, aby nie zranić się podczas obchodzenia się z szklanymi płytami i ich montażem

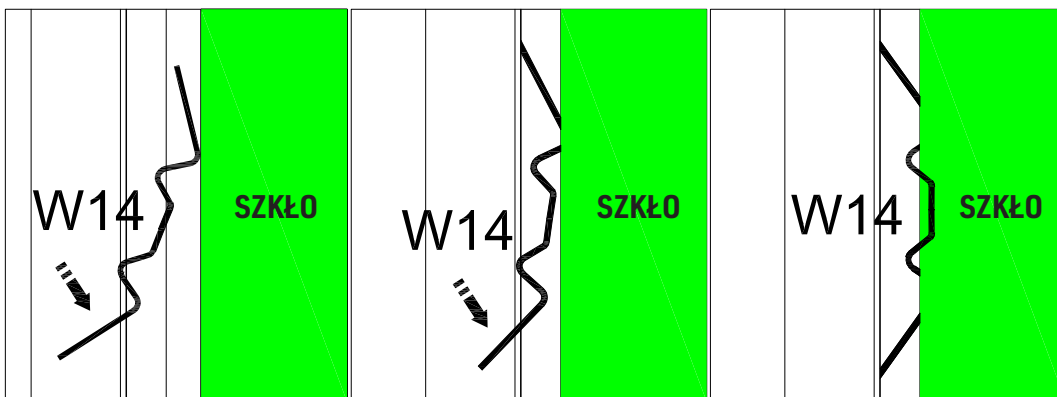
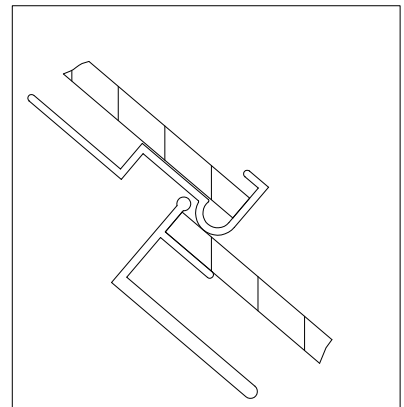

Podczas montażu zatrząsków do szkła W14 należy uważać, aby się nie skałeczyć

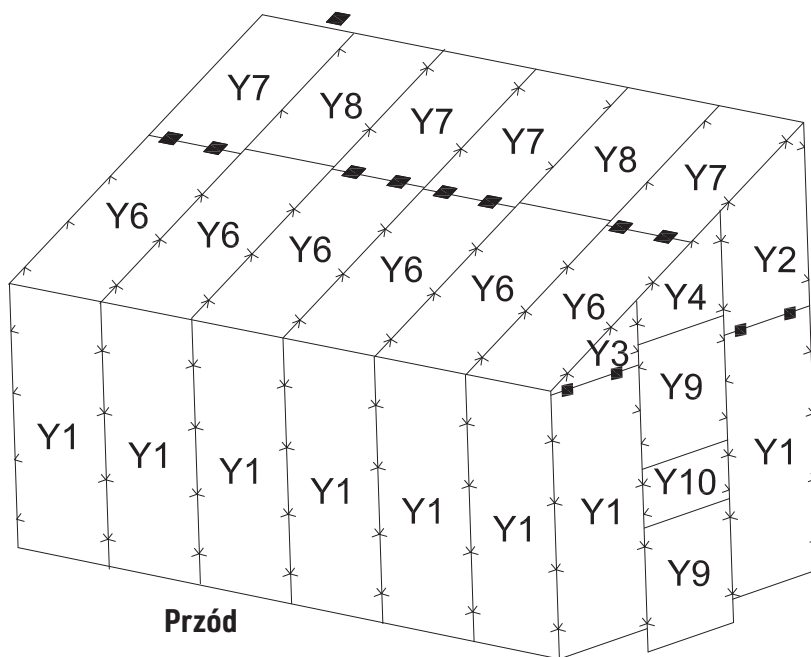

Przód

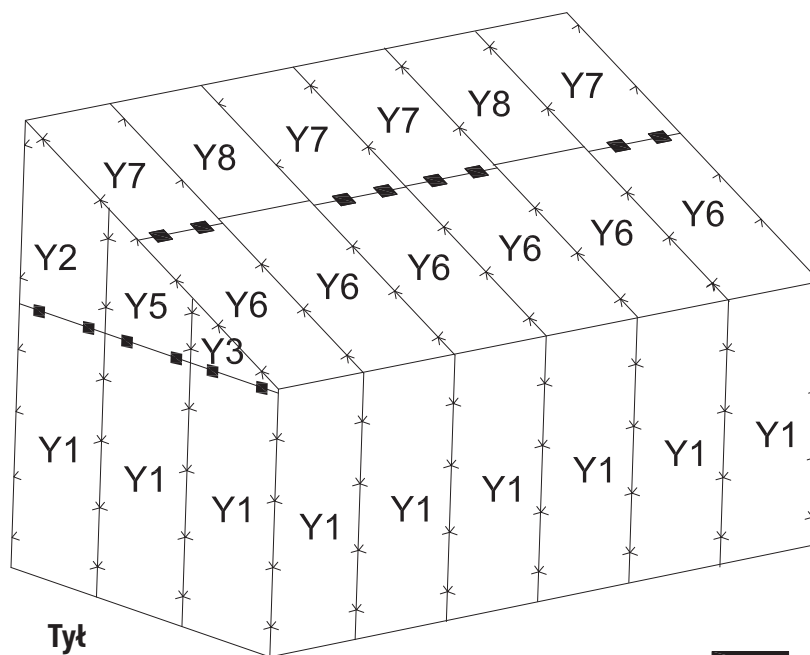

Tył



Części	Ref	mm	Ilość
	Y1	610x1472	11
	Y2	610x904x619	2
	Y3	610x326x41	2
	Y4	608x292x10	1
	Y5	610x616X330	1

Części	Ref	mm	Ilość
	Y6	610x1338	6
	Y7	610x738	4
	Y8	602x726	2
	Y9	629x609	2
	Y10	629x395	1

